



water solutions

Data sheet

GRG 300/2/G50H C0ET5



GREY
series

Technical specification

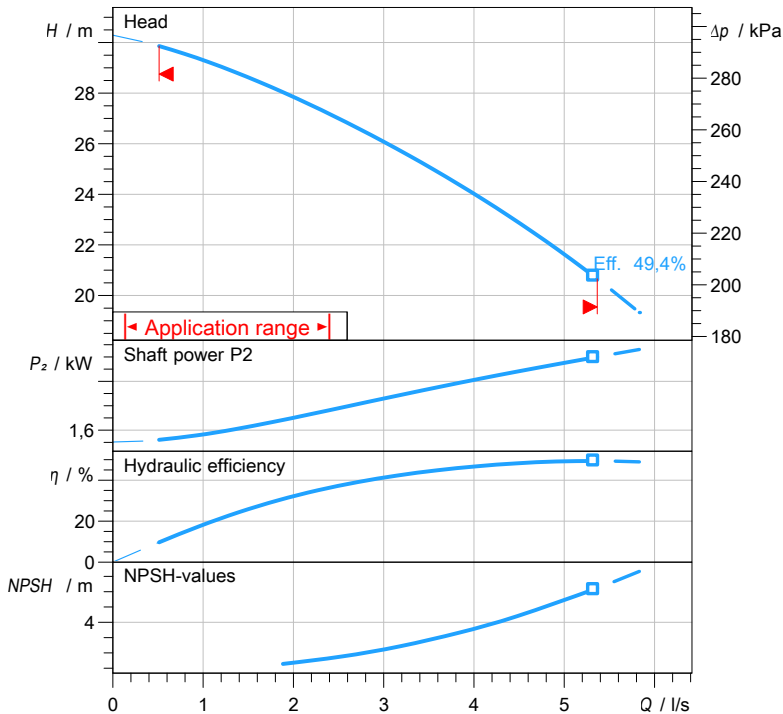
3~ 50 Hz

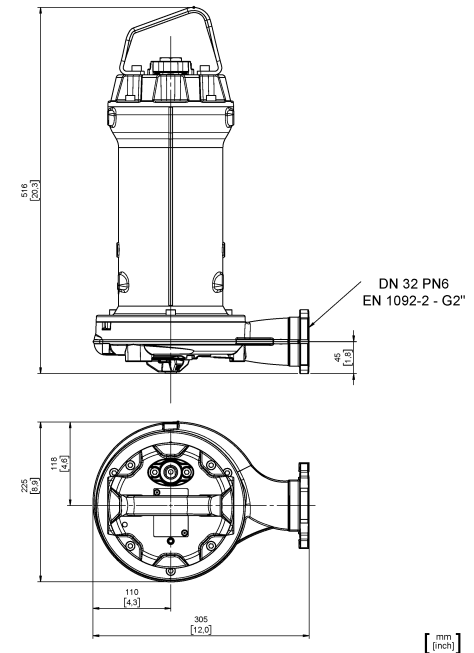

Characteristic curves according to UNI EN ISO 9906:2012
P2 < 10kW: paragraph 4.4.2
10kW < P2 < 100kW: Grade 3B
P2 > 100kW: Grade 2B



Pump

Series	GREY series
Pump name	GRG 300/2/G50H C0ET5
Configuration	NGTSB5104N00EX
Standard	ATEX 2014/34/EU
ATEX mark	II 2G Ex db IIB T4 Gb Ex h IIB T4 Gb

Operating limits (standard pumps)

Max. ambient temperature	40 °C
Max. density treated liquid	1100 kg/m ³
pH treated liquid	6 ÷ 14
Max. start per hour (equally distributed)	30
Wet/dry use	WET
Max. acoustic pressure level	70 dB
Operating mode	S1 - Continuous use

Motor data

Rated voltage	400 V
Frequency	50 Hz
Motor phases	3~
Number of poles	2
Rated power P2	2,20 kW
Incoming power P1	2,76 kW
Rated current	4,6 A
rpm	2880 1/min
Efficiency	79,7 %
cos φ	0,862
Rated torque	7,3 Nm
Start	Direct starting
Starting current	28,2 A
Degree of protection	IP 68
Insulation class	H
Capacitor	
Starting Capacitor	

Construction materials

Case	Cast iron EN-GJL 250
Shaft	Stainless steel AISI 431
Hydraulic	Cast iron EN-GJL 250
Impeller	Cast iron EN-GJL 250
Painting/Coating	Bi-epoxy 200 μm sea water resistant
Screws	Stainless steel - Class A2-70
Gaskets	NBR
Cutter	Chromium steel - X102 CrMo17 KU
Cutting disk	Chromium steel - X102 CrMo17 KU

Construction features

Cooling system	No cooling jacket
Main cable	4G1,5 + 3x1
Cable length	10 mt
Mechanical seals	2 in silicon carbide (2SiC)
Additional drilling	-
Weight*	43,2 kg
Electrical variant	Thermal protection and leakage sensor

* cable, stand and guiding system excluded

Hydraulic

Type	GR (Impeller with grinder system)
Free passage	0 mm
Impeller type	Open channel impeller with grinder system
Max. hydraulic efficiency	49,4 %
Suction	
Discharge	DN 32 - G 2" EN 1092-2



water solutions

Data sheet GRG 300/2/G50H C0ET5



GREY
series

Pump performance curves

3~ 50 Hz

Hydraulic type GR (Impeller with grinder system)		Impeller type Open channel impeller with grinder system		Free passage 0 mm	Discharge DN 32 - G 2"	Suction
DUTY POINT						
Flow	Head	Shaft power P2	Hydraulic efficiency	Density 998,3 kg/m ³	Viscosity 1,005 mm ² /s	

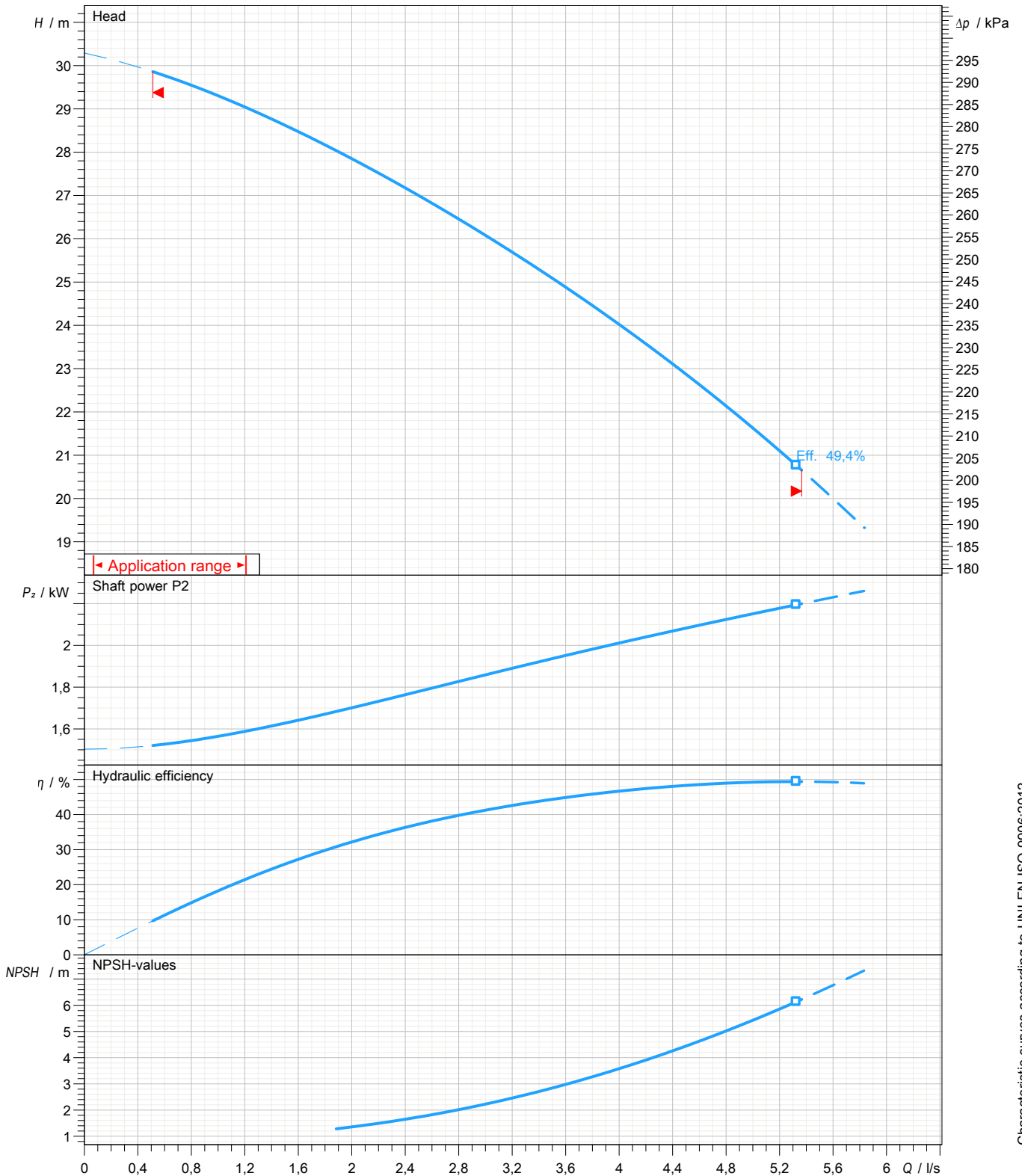

Characteristic curves according to UNI EN ISO 9906:2012
 P₂<10kW: paragraph 4.4.2
 10kW<P₂<100kW: Grade 3B
 P₂>100kW: Grade 2B



water solutions

Data sheet

GRG 300/2/G50H C0ET5



GREY series

Dimensional drawing

3~ 50 Hz

Installation type Installation with base plate		
Wet/dry use WET	Drilling variant N	Flushing valve - drilling -
Discharge DN 32 - G 2" EN 1092-2	Suction	Pressure rating (suction/discharge) PN 6
Accessory KBS 3F I184 (S)		Accessory code 9024.006
Note: Accessory must be ordered separately		

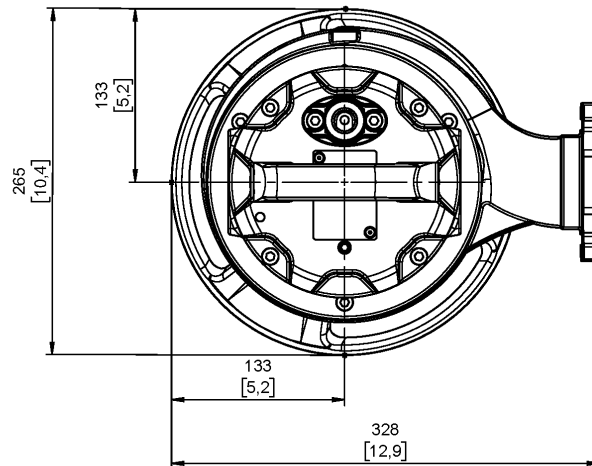
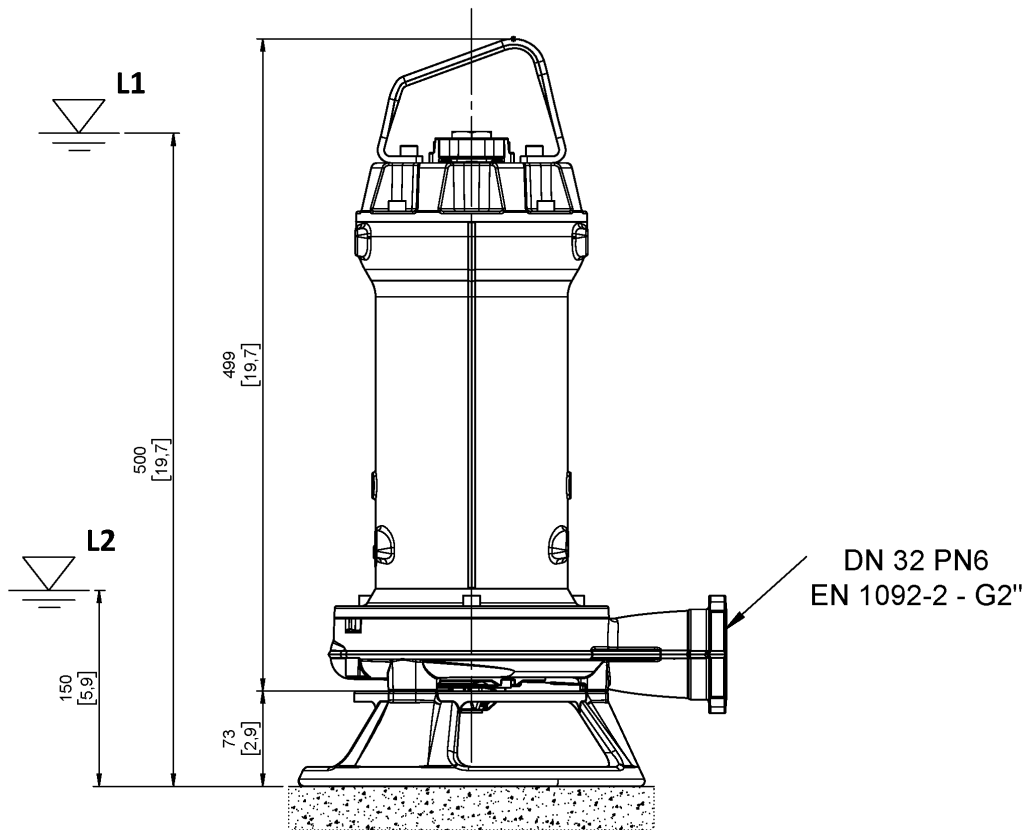

[mm]
[inch]

L1: Minimum operating level for continuous use

L2: Minimum operating level for discontinuous use