

Technical Data Sheet



HP 100x65-250 HYDRAULIC BARE SHAFT PUMP

Close Coupled Hydraulic Driven Water Pump

The Australian designed and manufactured hydraulically driven pump system comprises an ISO 100-65-250 pump close coupled to a high speed, low torque hydraulic motor. Making it a quieter more efficient unit than others in the market.

Whether it be bulk fluid transfer or dust suppression systems, the HP100x65-250 pump system has the versatility to handle your application.

Product Features

- **Compact Unit**
400mm shorter than a "standard" assembly.
- **External Grease Points**
For ease of service.
- **Unique Close Coupled Motor Assembly**
For an efficient, space saving and quiet operation.
- **Minimal Moving Parts**
For long trouble free life.
- **2 Pack Coated**
To provide protection under harsh conditions.
- **Optional Stainless Steel Impellor**
For potable water applications.



Pumps and Pipes

PP&S Pty Ltd
ABN 46 169 428 504

52 Moss Street, Slacks Creek QLD 4127
Ph: (07) 3208 9499

sales@pumpsandpipes.net.au
www.pumpsandpipes.net.au

Technical Data Sheet

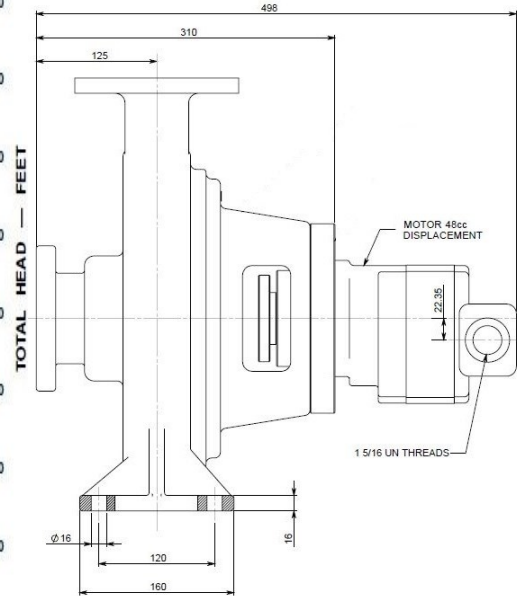
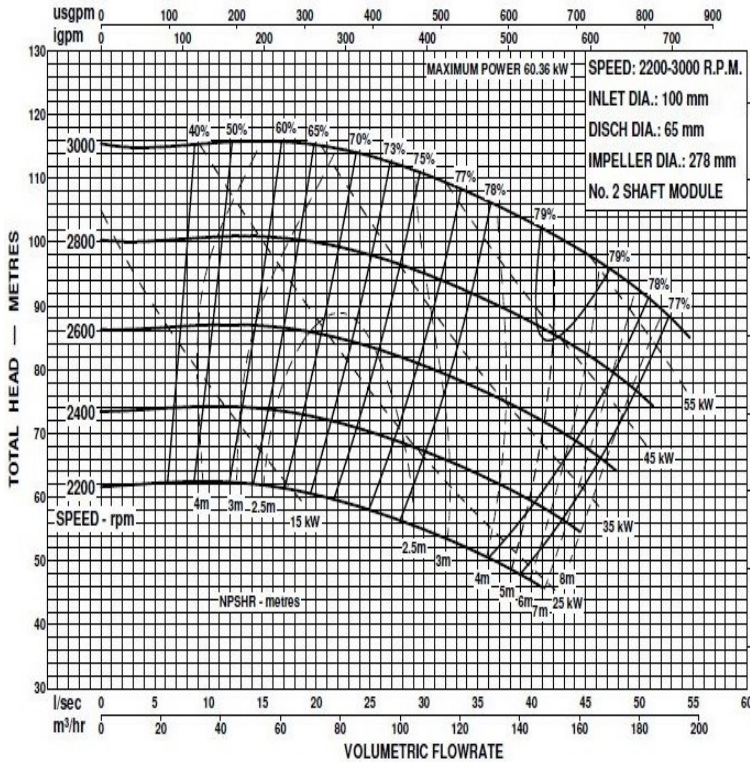

Performance to AS2417 Grade 2 for clean, cold water only.

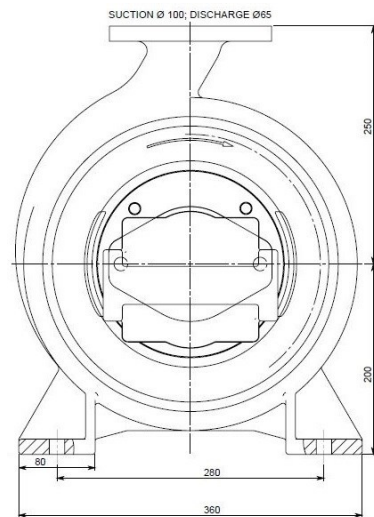
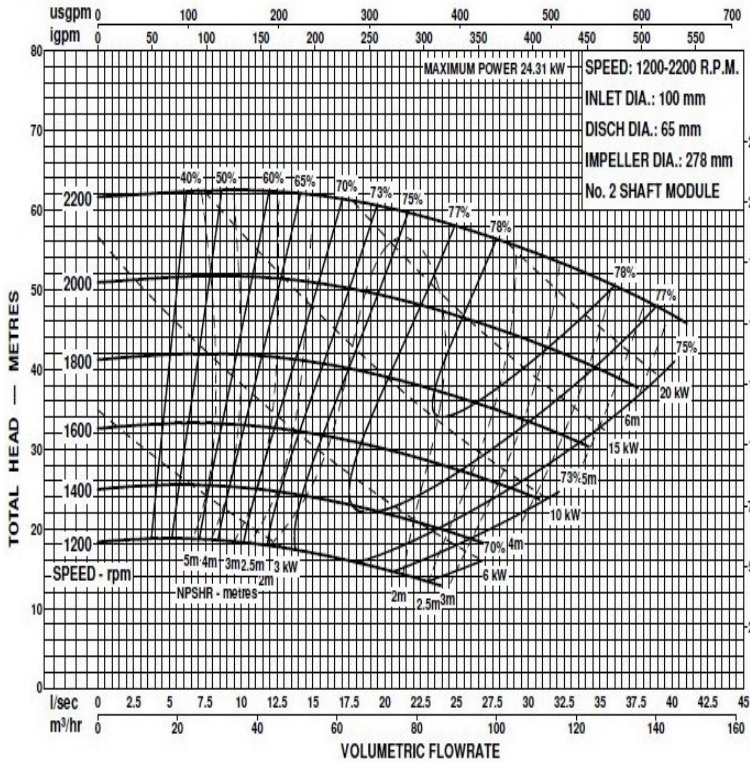

Performance to AS2417 Grade 2 for clean, cold water only.



Pumps and Pipes

PP&S Pty Ltd
 ABN 46 169 428 504

52 Moss Street, Slacks Creek QLD 4127

Ph: (07) 3208 9499

sales@pumpsandpipes.net.au

www.pumpsandpipes.net.au