



### MODEL NUMBER STRUCTURE

<b>U</b>	Ultraflow
<b>M</b>	'M' indicates Manual, without floatswitch
<b>HDD</b>	'HDD' indicates 'Heavy Duty Drainage' series
<b>N</b>	'N' indicates new series
<b>7500</b>	Power consumption in 'Watts'
<b>100</b>	Outlet size
<b>3</b>	'3' indicates 415 volt three phase

### SPECIFICATIONS

Power	7.5kW / 10.0HP
Frequency	50Hz
Discharge	100mm / 4 inch female BSP
Weight (Excl cable)	88Kg
Solid Passage	10 mm
Phase	3ø
Voltage	415
Full Load Amps	14.5
Maximum Liquid Temperature	0-40° C
Maximum Submersion Depth	30m (100 feet)
Motor type	Dry motor
Motor Speed	2 Pole (2800 rpm)
Motor Insulation	Class F
Motor Protection	IP68
Protector	Auto cut
Motor Bearings	Ball Type
	Dual Mechanical seal
Seal Method	Upper: Carbon/Ceramic Lower: Silicon/Silicon
Impeller Type	Enclosed Channel
Motor Cover Construction	FC-200 Cast Iron
Motor Casing Construction	FC-200 Cast Iron
Motor Shaft Construction	304 Stainless Steel
Pump Casing Construction	FC-200 Cast Iron
Outer Pump Jacket Construction	304 Stainless Steel
Impeller Construction	Hi-Chromium
Wear Ring	Hi-Chromium
Strainer Construction	304 Stainless Steel
Cable Material	H07RN-F

### PERFORMANCE CURVES

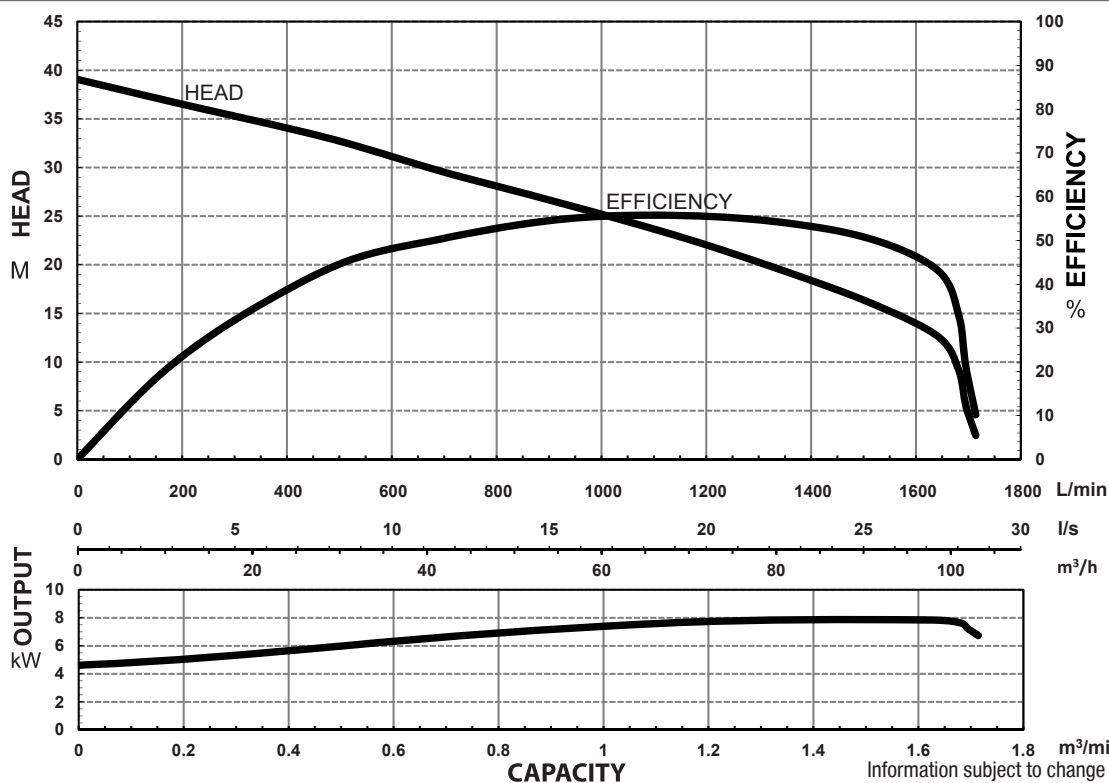

Information subject to change without notice.

Models: UMHDDN7500/100/3



## SECTIONAL DRAWING &amp; MATERIALS LIST

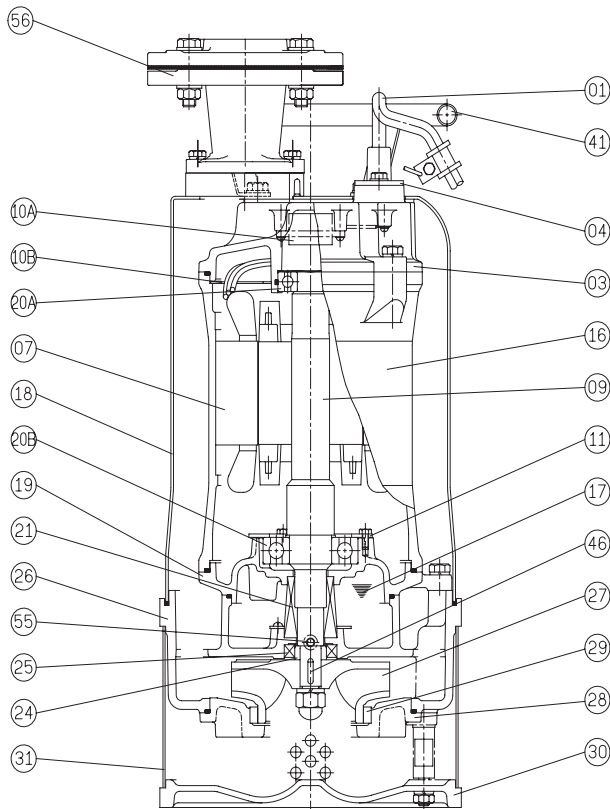

PART NUMBER	DESCRIPTION	MATERIAL
01	Cable	H07RN-F
03	Upper Motor Cap/ Upper Bearing Housing	Cast Iron FC-200
07	Motor Stator	
09	Shaft With (With Rotor)	(Shaft) Stainless Steel 304
10A	Auto Cut Out Overload	
10B	Auto Cut Out Mounting Plate	
11	Bearing Fixing Plate	
16	Motor Casing	Cast Iron FC-200
17	Lubricant	Turbine Oil
18	Outer Cover	304 Stainless Steel
19	Lower Bearing Housing	Cast Iron FC-200
20A & 20B	Upper Bearing & Lower Bearing	
21	Mechanical Seal	Upper: Carbon/Ceramic Lower: Silicon/Silicon
24	Oil Seal Bush	403 Stainless Steel
25	Oil Seal	Nitrile
26	Pump Casing	Cast Iron FC-200
27	Impeller	High Chromium HiCr
28	Suction Cover (with wear ring)	Cast Iron FC-200
29	Wear Plate	High Chromium HiCr
30	Base Foot	Cast Iron FC-200
31	Strainer	304 Stainless Steel
41	Handle	304 Stainless Steel
46	Impeller Key	304 Stainless Steel
47	O'rings	
55	Oil Plug	304 Stainless Steel
56	Outlet Flange Kit	

## PUMP OUTLET DIMENSIONS

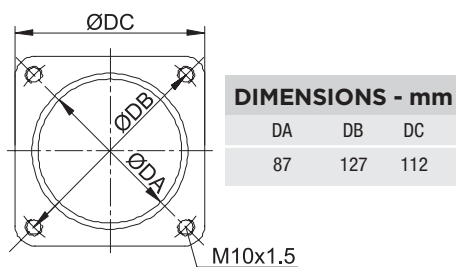

## LKF4-175\*127PT OUTLET FLANGE KIT DIMENSIONS

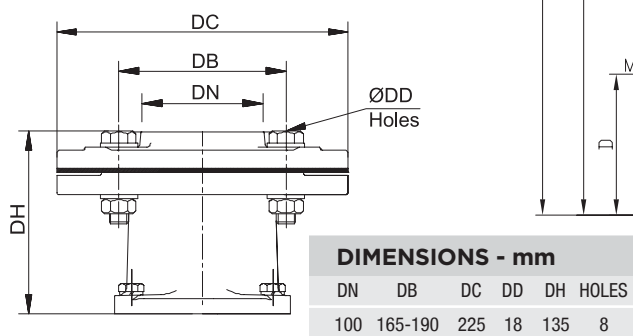

To ordering spare parts as above, it will be necessary to add the model number of the code listed above. For example, a power lead for a UMHDDN7500/100/3 would be written as '01- UMHDDN7500/100/3'.

## DIMENSIONAL DRAWING

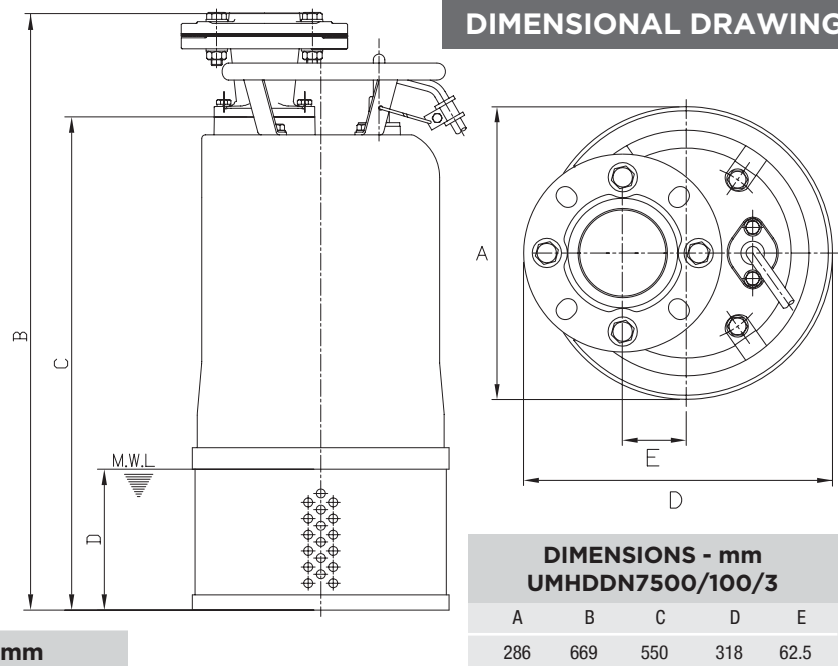

Information subject to change without notice.