



MODEL NUMBER STRUCTURE

U	Ultraflow
M	'M' indicates Manual, without floatswitch
HDD	'HDD' indicates 'Heavy Duty Drainage' series
A	'A' indicates agitator
N	'N' indicates new series
3700	Power consumption in 'Watts'
80	Outlet size
3	'3' indicates 415 volt single phase

SPECIFICATIONS

Power	3.7kW / 5.0HP
Frequency	50Hz
Discharge	80mm / 3 inch female BSP
Weight (Excl cable)	55Kg
Solid Passage	10 mm
Phase	3ø
Voltage	415
Full Load Amps	7.9
Maximum Liquid Temperature	0-40° C
Maximum Submersion Depth	30m (100 feet)
Motor type	Dry motor
Motor Speed	2 Pole (2800 rpm)
Motor Insulation	Class F
Motor Protection	IP68
Protector	Auto cut
Motor Bearings	Ball Type
Seal Method	Dual Mechanical seal
	Upper: Carbon/Ceramic Lower: Silicon/Silicon
Impeller Type	Enclosed Channel
Motor Cover Construction	FC200 Cast Iron
Motor Casing Construction	FC200 Cast Iron
Motor Shaft Construction	403 Stainless Steel
Pump Casing Construction	FC-200 Cast Iron
Outer Pump Jacket Construction	304 Stainless Steel
Impeller Construction	Hi-Chromium
Wear Ring	Hi-Chromium
Agitator	FCD-700
Strainer Construction	304 Stainless Steel
Cable Material	H07RN-F

PERFORMANCE CURVES

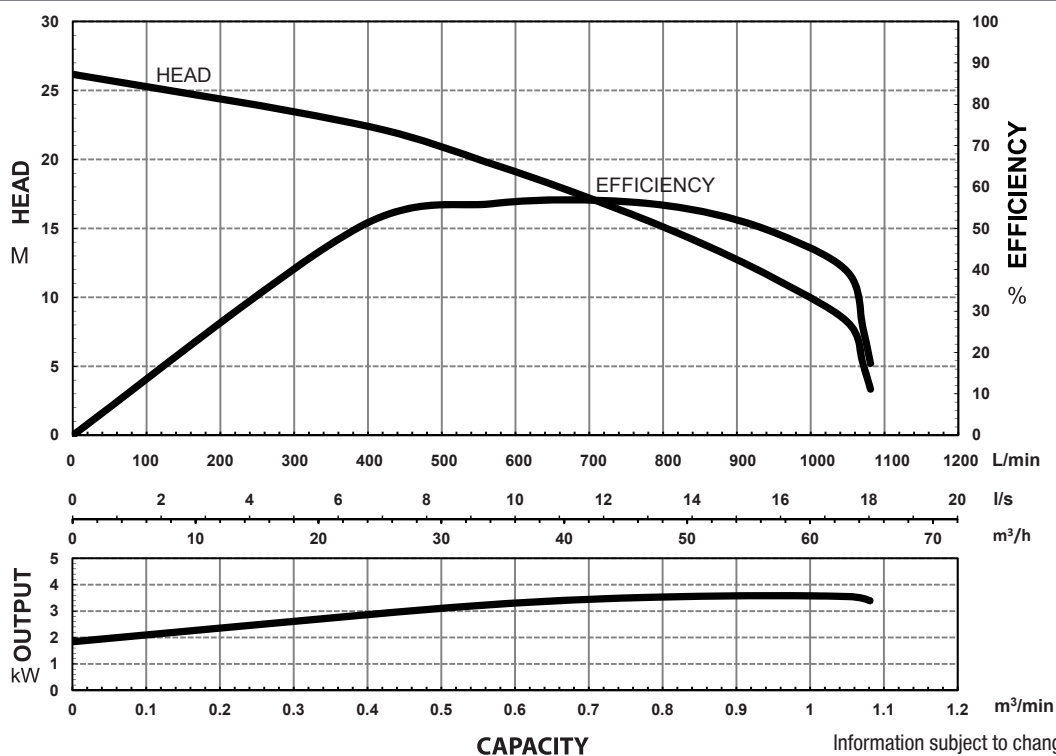

Information subject to change without notice.

Models: **UMHDDAN3700/80/3**

SECTIONAL DRAWING & MATERIALS LIST

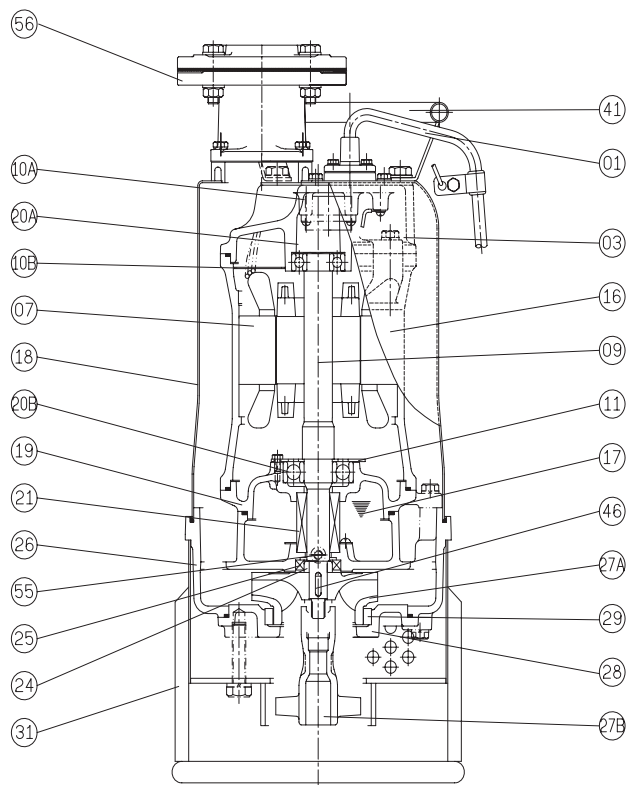

PART NUMBER	DESCRIPTION	MATERIAL
01	Cable	H07RN-F
03	Upper Motor Cap/ Upper Bearing Housing	Cast Iron FC-200
07	Motor Stator	
09	Shaft With (With Rotor)	(Shaft) Stainless Steel 403
10A	Auto Cut Out Overload	
10B	Auto Cut Out Plate	
11	Bearing Fixer	
16	Motor Casing	Cast Iron FC-200
17	Lubricant	Turbine Oil
18	Outer Cover	304 Stainless Steel
19	Lower Bearing Housing	Cast Iron FC-200
20A & 20B	Upper Bearing & Lower Bearing	
21	Mechanical Seal	Upper: Carbon/Ceramic Lower: Silicon/Silicon
24	Oil Seal Bush	403 Stainless Steel
25	Oil Seal	Nitrile
26	Pump Casing	Cast Iron FC-200
27A	Impeller	High Chromium HiCr
27B	Agitator	FCD700
28	Casing Cover	Cast Iron FC-200
29	Wear Ring	High Chromium HiCr
31	Strainer/Stand	304 Stainless Steel
41	Handle	304 Stainless Steel
46	Impeller Key	304 Stainless Steel
47	O'rings	
55	Oil Plug	304 Stainless Steel
56	Outlet Flange Kit	

To ordering spare parts as above, it will be necessary to add the model number of the code listed above. For example, a power lead for a UMHDDAN3700/80/3 would be written as '01- UMHDDAN3700/80/3'.

PUMP OUTLET DIMENSIONS

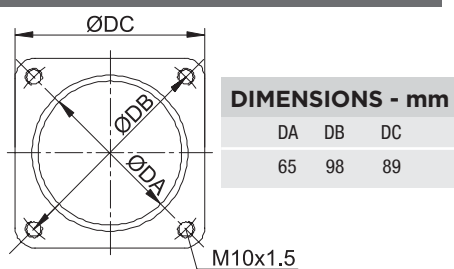

LKF3-150*98PT OUTLET FLANGE KIT DIMENSIONS

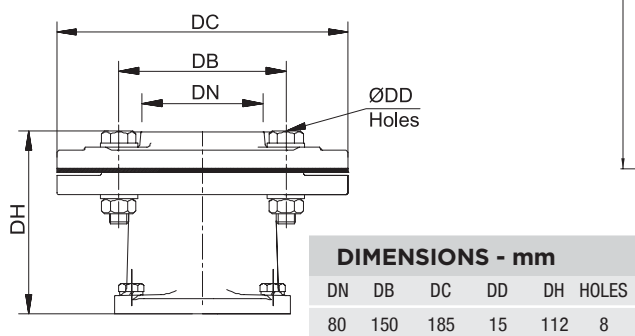

DIMENSIONAL DRAWING

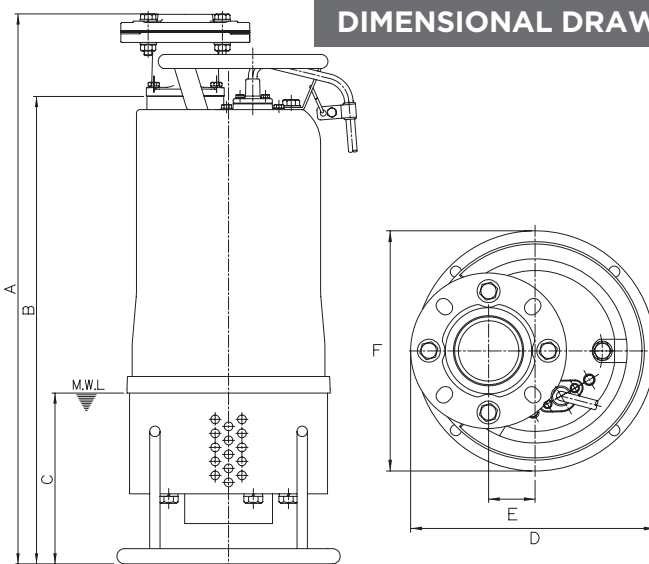

DIMENSIONS - mm UMHDDAN3700/80/3

A	B	C	D	E	F
644	532	195	273	50	260

Information subject to change without notice.