



SPECIFICATIONS

Power	7.5kW / 10HP
Frequency	50Hz
Discharge	100mm / 4 inch BSP
Weight (Excl cable)	125Kg
Solid Passage	76 mm
Phase	3ø
Voltage	415
Full Load Amps	16.0
Maximum Liquid Temperature	0-40° C
Maximum Submersion Depth	10m (33 feet)
Motor type	Dry motor
Motor Speed	4 Pole (1440 rpm)
Motor Insulation	Class F
Motor Protection	IP68
Protector	Auto-Cut
Motor Bearings	Ball Type
	Dual Mechanical seal
Seal Method	Upper: Carbon/Ceramic Lower: Silicon/Silicon
Impeller Type	Enclosed-channel
Motor Cover Construction	FC-200 Cast Iron
Motor Casing Construction	FC-200 Cast Iron
Motor Shaft Construction	420J2 Stainless Steel
Pump Casing Construction	FC-200 Cast Iron
Impeller Construction	FC-200 Cast Iron
Cable Material	H07RN-F

MODEL NUMBER STRUCTURE

U	Ultraflow
M	'M' indicates Manual, without floats witch
D	'D' indicates 'Drainage' series
Z	'Z' indicates New series
HF	'HF' indicates High Flow series
7500	Power consumption in 'Watts'
100	Outlet size
3	'3' indicates 415 volt three phase

PERFORMANCE CURVES

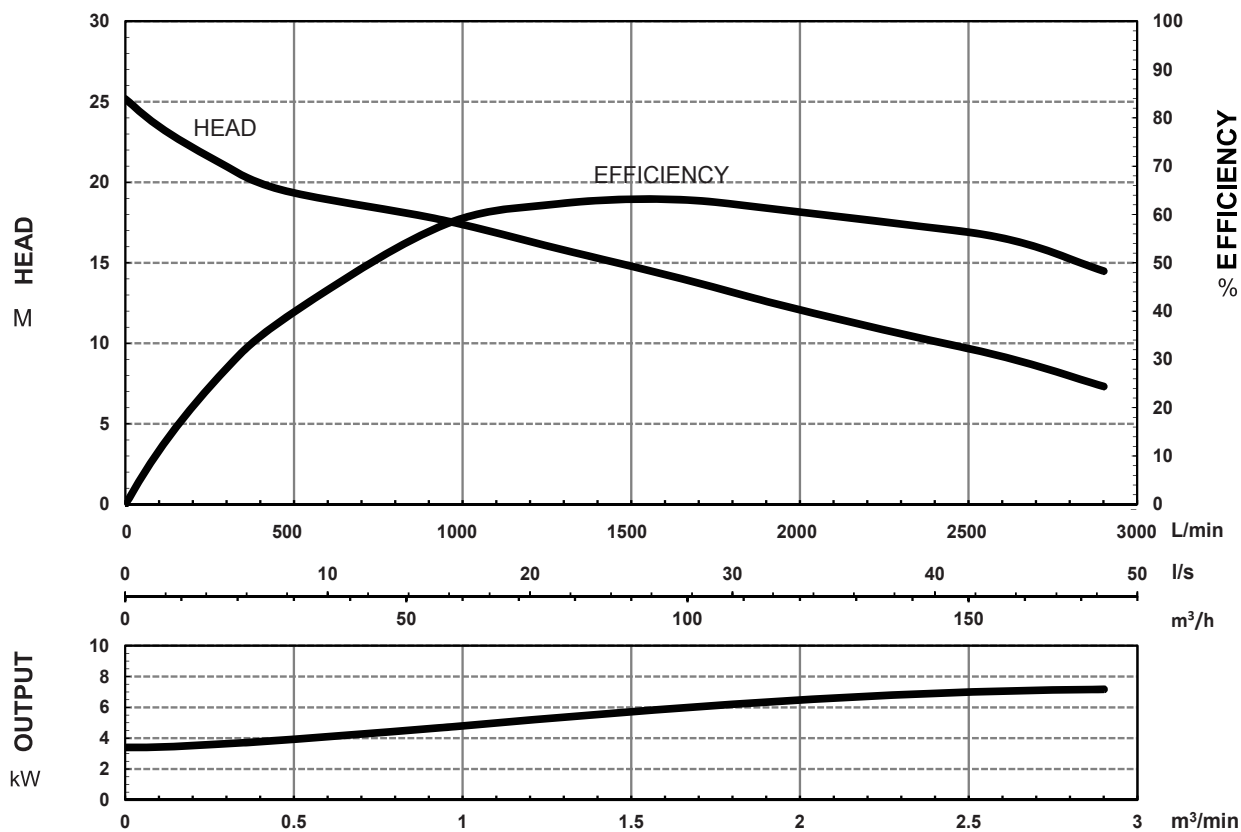

Information subject to change without notice.

SECTIONAL DRAWING & MATERIALS LIST

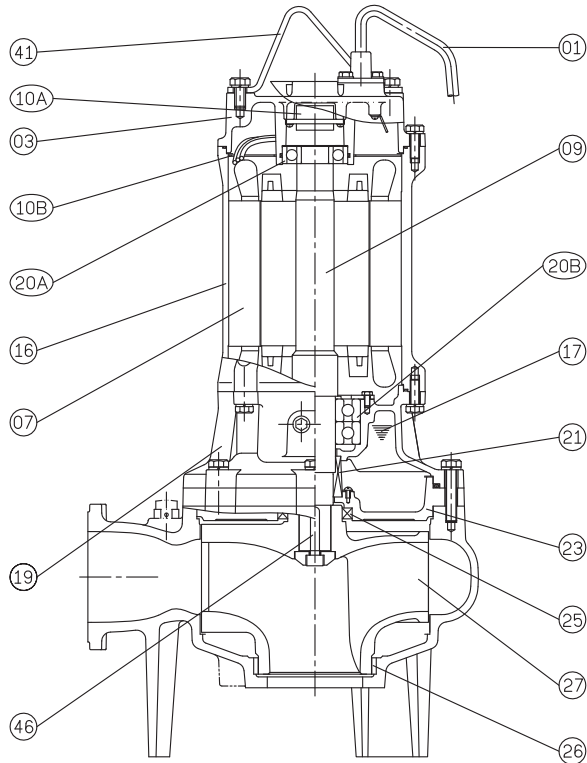

PART NUMBER	DESCRIPTION	MATERIAL
01	Cable	H07RN-F
03	Upper Motor Cap/ Bearing Housing	Cast Iron FC-200
07	Motor Stator	
09	Shaft (With Rotor)	(Shaft) Stainless Steel 420
10A	Auto Cut Out Overload	
10B	Auto Cut Out Overload	
16	Motor Casing	Cast Iron FC-200
17	Lubricant	Turbine Oil
19	Lower Bearing Housing	Cast Iron FC-200
20A	Upper Bearing	
20B	Lower Bearing	
21	Mechanical Seal	Upper: Carbon/Ceramic Lower: Silicon/Silicon
23	Mechanical Seal Housing	Cast Iron FC-200
25	Oil Seal	Nitrile
26	Pump Casing	Cast Iron FC-200
	Wear ring	BC6 Bronze
27	Impeller	Cast Iron FC-200
41	Handle	Steel
46	Impeller Key	304 Stainless Steel
47	O'rings	
55	Oil Plug	304 Stainless Steel

When ordering spare parts as above, simply add the pump model number to the part number from the list above. For example, a power lead (part '01'). the complete spare part name would be written as '01-UMDZHF7500/100/3'.

DIMENSIONAL DRAWING

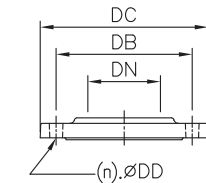
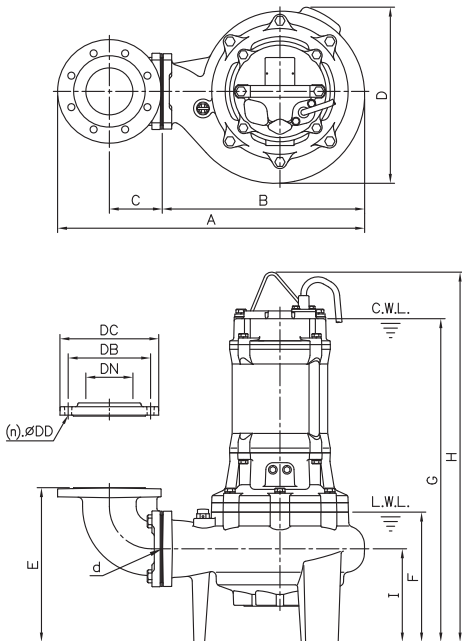

DIMENSIONS - mm

DN	DB	DC	DD
100	175	210	15

DIMENSIONS - UMDZHF7500/100/3

d	A	B	C	D	E	F	G	H	I
100	653	430	113	374	328	276	727	826	198

GUIDE RAIL SYSTEM DIMENSIONS USING GR100EB GUIDE RAIL KIT

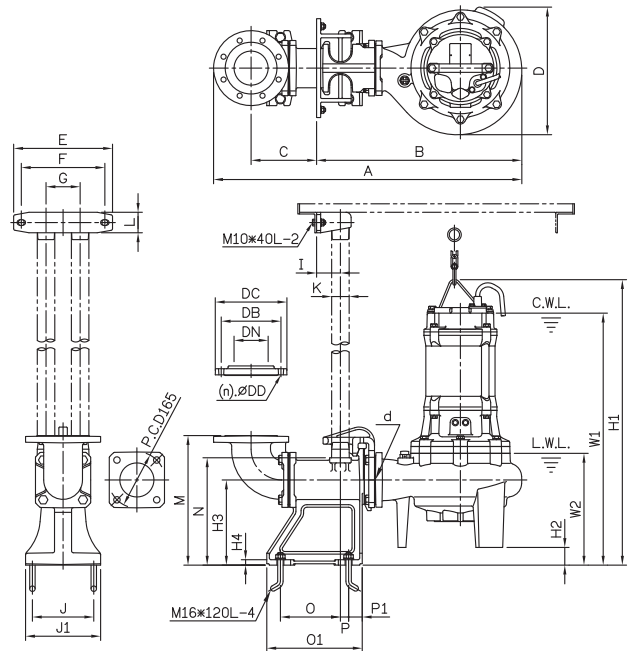

DIMENSIONS - UMDZHF7500/100/3

d	A	B	C	D	E	F	G	I	J	J1	K	L	M	N	O	O1	P	P1	W1	W2	H	H2	H3	H4
100	907	605	192	374	290	245	100	70	180	220	50	60	380	315	176	280	24	40	779	328	878	52	250	16

Information subject to change without notice.