

**MODELS:** UMGN1500/32/1  
 UAGN1500/32/1  
 UMGN1500/32/3  
 UAGN1500/32/3  
 UAGN1500/32/1-FSLC



SPECIFICATIONS	
Power	1.5kW / 2.0HP
Frequency	50Hz
Discharge	32mm / 1 1/4 inch female BSP
Weight (Excl cable)	36Kg (33Kg – UMGN1500/32/3)
Phase	1ø                      3ø
Voltage	240                      415
Full Load Amps	9.8                      3.4
Maximum Liquid Temperature	0-40° C
Maximum Submersion Depth	30m (100 feet)
Motor type	Dry motor
Motor Speed	2 Pole (2800 rpm)
Motor Insulation	Class B
Motor Protection	IP68
Protector	Auto cut
Motor Bearings	Ball Type
Seal Method	Dual Mechanical seal Upper: Carbon/Ceramic Lower: Silicon/Silicon
Impeller Type	Semi-open
Motor Cover Construction	FC-200 Cast Iron
Motor Casing Construction	FC-200 Cast Iron
Motor Shaft Construction	403 Stainless Steel
Pump Casing Construction	FC-200 Cast Iron
Impeller Construction	FC-200 Cast Iron
Grinder	Heat Treated 440 Stainless Steel
Grinder Ring	Heat Treated 440 Stainless Steel
Cable Material	H07RN-F



### MODEL NUMBER STRUCTURE

UMGN1500/32/1

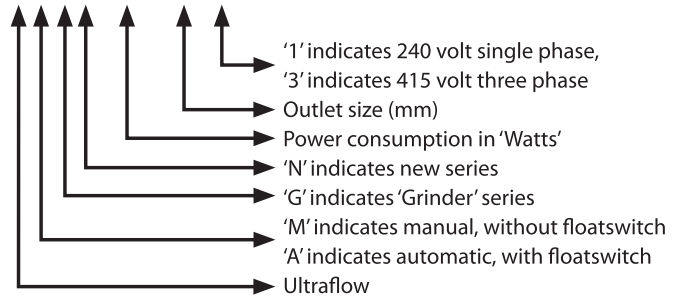

\*\*FSLC indicates pump is fitted with a fixed stainless steel arm bracket for floatswitch models which are used in applications to prevent the floatswitch from interfering with the sides of small pump wells\*\*

### PERFORMANCE CURVES

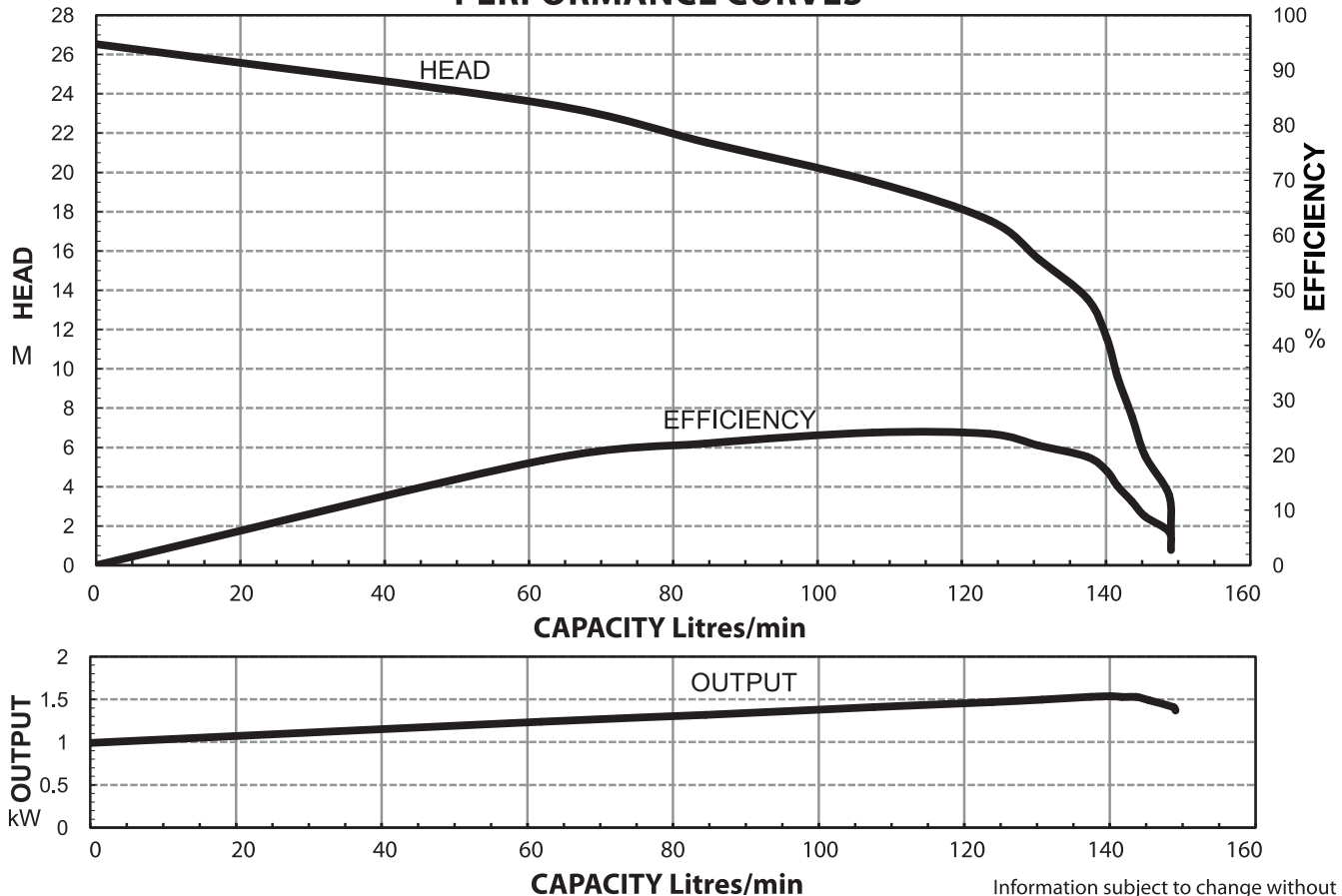

Information subject to change without notice.



97 Gascoigne Street, Kingswood 2747 New South Wales, Australia  
 Phone: 02 4731 3940 Fax: 02 4731 3366  
 Email: sales@ultraflowaustralia.com.au Web: www.ultraflowaustralia.com.au

**MODELS:** UMGN1500/32/1  
 UAGN1500/32/1  
 UMGN1500/32/3  
 UAGN1500/32/3  
 UAGN1500/32/1-FSLC



## SECTIONAL DRAWING & MATERIALS LIST

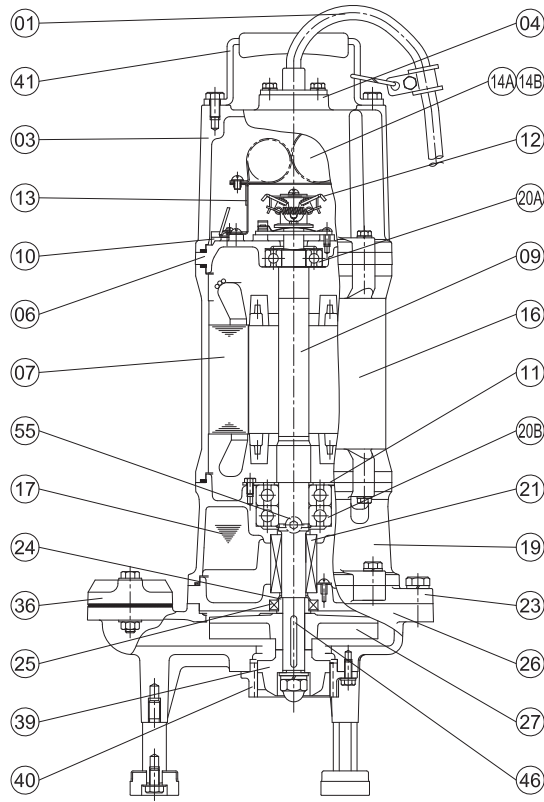

Part Number	Description	Material/Notes
01	Cable	HO7RN-F
03	Upper Motor Cap	Cast Iron FC-200
04	Cable Gland Cover	
06	Upper Bearing Housing	Cast Iron FC-200
07	Motor Stator	
09	Shaft With (With Rotor)	(Shaft) Stainless Steel 403
10	Auto Cut Out Overload	
11	Bearing Fixer	
12	Centrifugal Switch (240 volt models only)	(Transformer relay for UAGN1500/32/3)
14A	Capacitor (240 volt models)	
14B	Start Capacitor	(240 volt models only)
16	Motor Casing	Cast Iron FC-200
17	Lubricant	Turbine Oil
19	Lower Bearing Housing	Cast Iron FC-200
20A	Upper Bearing	
20B	Lower Bearing	
21	Mechanical Seal	Upper: Carbon/Ceramic Lower: Silicon/Silicon
23	Mechanical Seal Housing	Cast Iron FC-200
24	Oil Seal Bush	
25	Oil Seal	Nitrile
26	Pump Casing	Cast Iron FC-200
27	Impeller	Cast Iron FC-200
36	Outlet Flange	Cast Iron FC-200
39	Grinder	Heat Treated 440 Stainless Steel
40	Grinder ring	Heat Treated 440 Stainless Steel
41	Handle	304 Stainless Steel
46	Impeller Key	304 Stainless Steel
47	O'rings	
55	Oil Plug	304 Stainless Steel
FL	Floatswitch	

To order spare parts as above, it will be necessary to add the model number of the pump after the code listed above. For example, a power lead for a UAGN1500/32/1 would be written as '01-UAGN1500/32/1'.

### DIMENSIONAL DRAWING

### ELBOW (FLANGE) SET

### GUIDE RAIL SYSTEM DIMENSIONS USING GR50 GUIDE RAIL KIT

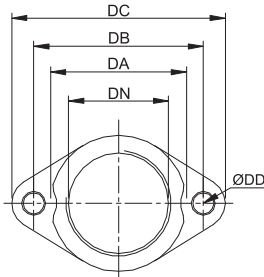
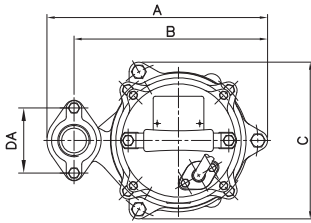

DIMENSIONS - mm				
DN	DA	DB	DC	DD
32	70	84	105	9.5

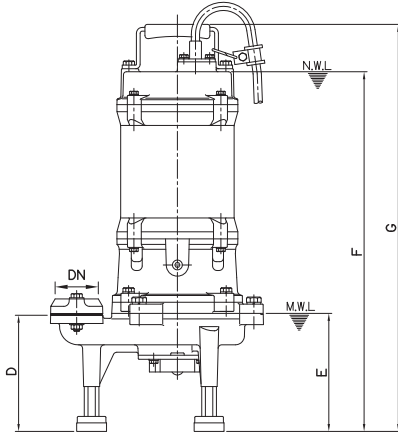
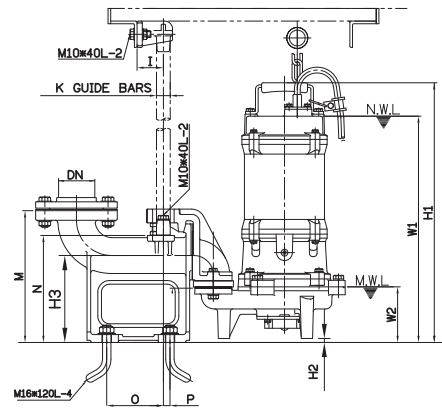
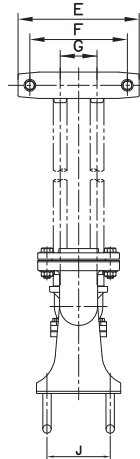
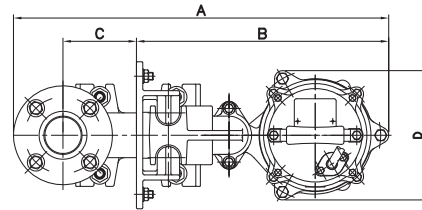

DIMENSIONS - mm							
UMGN1500/32/1, UAGN1500/32/1 & UAGN1500/32/3							
DN	DA	A	B	C	D	E	F
32	84	285	250	203	156	160	553
UMGN1500/32/3							
DN	DA	A	B	C	D	E	F
32	84	285	250	203	156	160	483

DIMENSIONS - mm																			
UMGN1500/32/1, UAGN1500/32/1 & UAGN1500/32/3																			
DN	A	B	C	D	E	F	G	I	J	K	M	N	O	P	W1	W2	H1	H2	H3
50	588	395	115	203	230	185	70	50	120	25	250	203	108	13	480	106	544	6	165
UMGN1500/32/3																			
DN	A	B	C	D	E	F	G	I	J	K	M	N	O	P	W1	W2	H1	H2	H3
50	588	395	115	203	230	185	70	50	120	25	250	203	108	13	430	106	493	6	165

PUMP LEGS TO BE UNSCREWED FOR GUIDE RAIL APPLICATIONS

Information subject to change without notice.