



The flexible capabilities of the Tyreflex Coupling help to accommodate angular, parallel and axial misalignments.

Parallel Misalignment upto 6 mm. Angular Misalignment upto 4°. End Float upto 8 mm. Suitable in ambient temp. upto 70°C.

CUSHIONING SHOCK LOADS

Tyreflex being a torsionally soft coupling protects against vibration, impact loads and heavy shocks in the event of sudden load changes.

EASE OF ASSEMBLY / DISASSEMBLY

Alignment is quickly checked by placing a straight edge across the outside diameters of the flanges.

Installation or replacement of new tyre is achieved without disturbing driver or driven shafts, simply by loosening the clamping screws, placing a new tyre between the flanges and clamping rings and then tightening the clamping screws.

TYRE-FLEX COUPLING - RST

Tyre-flex Spacer Couplings RST are specifically designed for motor-pump installations, where it is desirable not to disturb drive/driven equipment while servicing impellers, packing glands, etc.

The maintenance time-reduction feature is valuable on pumps, compressors and many other applications.

It comprises of a spacer assembly and a standard Tyre-flex coupling. The spacer assembly consists of a flanged shaft and a spacer adapter taper bored to suit standard Taper Bush.

SELECTION PROCEDURE - T/TO

(a) Service Factor

Determine the required service factor from table 1.

(b) Design Power

Multiply the normal running power by the service factor. This gives **Design Power** which is used as a basis for selecting the coupling.

(c) Coupling Size

Refer table 2 and from the appropriate speed read across until a power greater than that required is found. The size of Tyre-flex coupling required is given in that column..

(d) Bore Size

Check from table 3 that selected coupling can accommodate required bores.

SELECTION PROCEDURE - RST

1. Select a suitable size of Tyre-flex coupling using the procedure.
2. Refer size column in table A and locate the size of coupling selected.
3. Read across this size until required DBSE can be accommodated.
4. The size of the spacer coupling is given in the first column of table A.
5. Refer coupling dimensional table A to check that the required bores can be accommodated.

TABLE 1 : SERVICE FACTORS

SPECIAL CLASSES For applications where substantial shock, vibration and torque fluctuations occur and for reciprocating machines e.g. internal combustion engines, piston pumps and compressors, refer to Rathi Transpower Pvt. Ltd. with full application details for analysis.	Type of Driving Unit					
	Electric Motors Steam Turbines			Internal Combustion Engines Steam Engines Water Engines		
	Hours per day duty			Hours per day duty		
Type of Driven Machine	upto 10	over 10 to 16 incl.	Over 16	upto 10	over 10 to 16 incl.	Over 16
CLASS 1 Agitators, Brewing machinery, Centrifugal compressors and pumps, Belt Conveyors, Dynamometers, Lineshafts, Fans upto 7.5 kW, Blower and exhausters (except positive displacement), Generators.	0.8	0.9	1.0	1.3	1.4	1.5
CLASS 2 Clay working machinery, General machine tools, Paper mill beaters and winders, Rotary pumps, Rubber extruders, Rotary Screens, Textile Machinery, Marine Propellers, and Fans over 7.5 kW.	1.3	1.4	1.5	1.8	1.9	2.0
CLASS 3 Bucket elevators, Cooling tower fans, Piston compressors & pumps, Foundry machinery, Metal presses, Paper mill Calenders, Hammer mills, Presses and pulp grinders, Rubber Calenders, Pulverisers and Positive displacement blowers.	1.8	1.9	2.0	2.3	2.4	2.5
CLASS 4 Reciprocating conveyors, Gyrotory crushers, Mills (ball, pebble and rod). Rubber Machinery (Banbury Mixers and Mills) and Vibratory screens.	2.3	2.4	2.5	2.8	2.9	3.0

TABLE 2: POWER RATING (kW)

Speed rpm	Size T / TO														
	4	5	6	7	8	9	10	11	12	14	16	18	20	22	25
100	0.25	0.69	1.33	2.62	3.93	5.24	7.07	9.16	13.9	24.3	39.5	65.7	97.6	121	154
750	1.87	5.17	9.97	19.65	29.47	39.30	53.02	68.70	104.25	182.25	296.25	492.75	732	907.5	1155
1000	2.50	6.90	13.30	26.20	39.30	52.40	70.70	91.60	139.0	243.0	395.0	657.0	976	1215	1537
1500	3.75	10.35	19.95	39.30	58.95	78.60	106.05	137.40	208.50	364.50	592.50*	986.5*	-	-	-
1800	4.50	12.42	23.94	47.16	70.74	94.32	127.26	164.88	250.20	437.40*	-	-	-	-	-
3000	7.50	20.70	39.90	78.60	117.90*	157.20*	-	-	-	-	-	-	-	-	-
3600	9.00	24.84	47.98	94.32	-	-	-	-	-	-	-	-	-	-	-

- All these power ratings are calculated at constant torque.
- For speeds below 100 rpm and intermediate speeds use normal torque ratings.
- * Dynamic balancing preferred at these speeds.

Poles	2	4	6	8
rpm	3000	1500	1000	750

TECHNICAL DATA : FLEXIBLE TYRES

Size	4	5	6	7	8	9	10	11	12	14	16	18	20	22	25
Max. Speed rpm	4500	4500	4000	3600	3100	3000	2600	2300	2050	1800	1600	1500	1300	1100	1000
Torsional Stiffness Nm/Deg.	5	13	26	41	63	91	126	178	296	470	778	1371	1959	2760	3562
Parallel Misalignment mm	1.1	1.3	1.6	1.9	2.1	2.4	2.6	2.9	3.2	3.7	4.2	4.8	5.3	5.8	6.6
End Float mm	1.3	1.7	2.0	2.3	2.6	3.0	3.3	3.7	4.0	4.6	5.3	6.0	6.6	7.3	8.2
Normal Torque Nm	24	66	127	250	375	500	675	875	1330	2325	3730	6270	9325	11600	14675
Max. Torque Nm	64	160	318	487	759	1096	1517	2137	3547	5642	9339	16455	23508	33125	42740

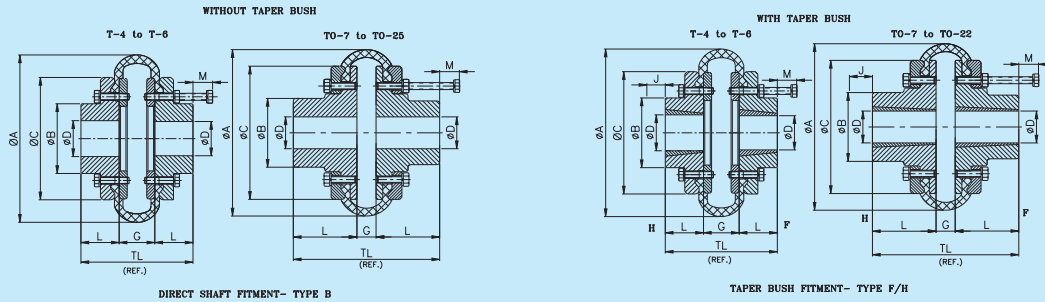

TABLE 3 : DIMENSIONS OF TYRE-FLEX HUB TYPES B, F & H

SIZE	KW @ 100 RPM	MAX. SPEED (RPM)	TYPE	# BUSH SIZE	BORE ØD		TYPE F/H			TYPE B		ØA	ØC	ØB	M	G	WT.(Kg)	M.I. (WR ²) Kg-m ²			
					PB	MAX.	TL	L	J	TL	L										
T-4	0.25	4500	B	-	10	32	-	-	-	68	22	104	82	-	17	24	1.9	0.00161			
			F/H	1008	-	25	68	22	29	-	-								1.7	0.00148	
T-5	0.69	4500	B	-	10	38	-	-	-	93	32	133	100	79	17	29	3.5	0.00358			
			F/H	1210	-	32	79	25	38	-	-								2.7	0.00349	
T-6	1.33	4000	B	-	15	45	-	-	-	111	38	165	125	73	8	35	5	0.0105			
			F/H	1610	-	42	85	25	38	-	-								103	19	3.6
TO-7	2.62	3600	B	-	19	50	-	-	-	106	45	197	144	82	-	16	8.4	0.0177			
			F	2012	-	50	80	32	38	-	-								9	6.35	0.0192
			H	1610	-	42	66	25													
TO-8	3.93	3100	B	-	25	63	-	-	-	124	51	210	167	96	10	22	11.5	0.0329			
			F	2517	-	60	112	45	42	-	-								9	8.53	0.0303
			H	2012	-	50	86	32													
TO-9	5.24	3000	B	-	30	75	-	-	-	138	57	235	188	110	-	24	16	0.0599			
			F/H	2517	-	60	114	45	48	-	-								12	0.0538	
TO-10	7.07	2600	B	-	32	80	-	-	-	144	60	254	216	125	-	24	22.7	0.1148			
			F	3020	-	75	126	51	48	-	-								18.2	0.1062	
			H	2517	-	60	114	45													18.1
TO-11	9.16	2300	B	-	32	90	-	-	-	152	65	279	233	140	-	22	28.3	0.1631			
			F/H	3020	-	75	124	51	55	-	-								21.1	0.1461	
TO-12	13.9	2050	B	-	38	100	-	-	-	177	76	314	264	152	-	24.5	40.1	0.2902			
			F	3525	-	90	154.5	65	55	-	-								30.33	0.2627	
			H	3020	-	75	126.5	51													30.3
TO-14	24.3	1800	B	-	58	127	-	-	-	201	89	359	311	195	26	32	60.6	0.6045			
			F/H	3525	-	90	153	65	67	-	-								42.6	0.4922	
TO-16	39.5	1600	B	-	65	140	-	-	-	212	102	395	345	216	-	30	86.4	1.2755			
			F/H	4030	-	100	162	77	80	-	-								72.6	1.1134	
TO-18	65.7	1500	B	-	70	150	-	-	-	254	116	470	398	220	-	46	133.3	2.1525			
			F/H	4535	-	115	200	89	89	-	-								123	1.9514	
TO-20	97.6	1300	B	-	70	150	-	-	-	258	114	508	429	220	-	48	144.6	3.1765			
			F/H	4535	-	115	208	89	89	-	-								158.3	3.0129	
TO-22	121	1100	B	-	75	160	-	-	-	281	127	562	470	240	-	54	181.63	4.7861			
			F/H	5040	-	125	231	102	92	-	-								195.1	4.8954	
TO-25	154	1000	B	-	85	190	-	-	-	294	132	628	532	275	-	60	281.1	8.129			

NOTES:

- 1) All Dimensions are in mm .
- 2) M is amount by which clamping screw need to be withdrawn to release tyre .
- 3) J is wrench clearance to allow for tightening and loosening of the bush on the shaft.
- 4) Shaft ends, although normally located G apart can project beyond flanges.
- 5) Weight & Moment of inertia specified for solid bores.
- 6) # For detailed information about Taper Bore, Please refer Taper Bush catalog.

T-4 to T-6

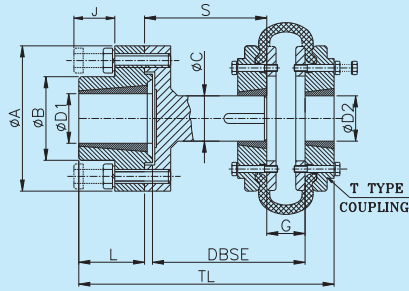

TO-7 to TO-14

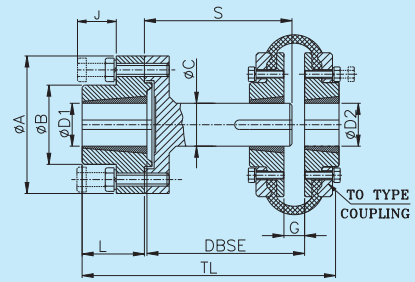

TABLE A : DIMENSIONAL DATA

SPACER SIZE	NOM. DBSE	BUSH.		ØA	ØB	TL		L	J	S		ØC	TYRE FLEX SIZE T/TO	BUSH		G	
		SIZE	MAX. BORE			T	TO			T	TO			SIZE	MAX. BORE	T	TO
RST-12	80 100	1210	32	118	83	130 150	-	25	22	57 77	-	25	4	1008	25	24	-
RST-16	100 140 100 140 100 140	1615	42	127	80	163 203 166 206 166 206	-	38	24	94 134 94 134 94 134	-	32	4* 4* 5 5 6 6	1008 1008 1210 1210 1610 1610	25 25 32 32 42 42	24 24 29 29 35 35	-
RST-25	100 140 180 100 140 180	2517	60	178	127	-	-	45	27	-	94 134 174 174 94 134 174 174	48	7F 7F 7F 8F 8F 8F 9 9	2012 2012 2012 2517 2517 2517 2517 2517	50 50 50 60 60 60 60 60	-	16 16 16 22 22 22 24 24
RST-30	140 180 140 180	3030	75	216	146	-	-	76	33	-	134 174 134 174	60	10F 10F 11 11	3020	75	-	24 24 22 22
RST-35	140 180 140 180	3535	90	248	178	-	-	89	33	-	134 174 134 174	80	12F 12F 14 14	3525	90	-	24.5 24.5 23 23

* T4 'B' flange must be used to fit spacer shaft.

For detailed information about Taper Bush bore, please refer Taper Bush catalogue.

● All dimensions are in mm unless otherwise specified.

TABLE B: DISTANCE BETWEEN SHAFT ENDS (DBSE)

Tyre-flex Size T/TO	RST12		RST 16				RST 25				RST 30				RST 35					
	80		100		140		100		140		180		140		180		140		180	
	Min	Max	Min	Max	Min	Max	Min	Max	Min	Max	Min	Max	Min	Max	Min	Max	Min	Max	Min	Max
4	80	100	100	113	140	153														
5			100	116	140	156														
6			100	124	140	164														
7 F							100	107	140	147	180	187								
8 F							100	112	140	152	180	192								
9									140	155	180	195								
10 F													140	151	180	191				
11													140	151	180	192				
12 F																	140	156	180	196
14																	140	153	180	193

NOTES :-

- 1) Non STD Spacers are available on request .
- 2) Refer Installation Instructions for Mounting and Dismounting. .

In view of our constant endeavour to improve quality of our products, we reserve the right to alter or change specifications without prior notice. This document is the intellectual property of Rathi Transpower Pvt. Ltd. and subject to copyright.



Rathi Transpower Pvt Ltd
 Gaia Apex, S. No. 33/2D, Viman Nagar
 Pune 411 014.(INDIA)
 Phone : 91-20-30517201
 Fax : 91-20-30517212
 E-mail : enquiry@rathigroup.com
 Website : www.rathicouplings.com

Distributor