



The pump is a horizontal single stage stainless steel centrifugal pump supplied wired and ready to install. Used especially for water transfer.

The pump is characterised by:

- Corrosion resistant 304 stainless steel pump body, impeller, diffuser, seal support and pump shaft.
- Mechanical shaft seal.
- 240V single phase TEFC motor with in-built auto reset thermal overload.
- Pump support plate.

Applications:

Suitable for urban water supply, garden irrigation and hot water applications including vat washing, clean in place, and circulation.

Package Information:

- 15 kg
- L 410mm x W 240mm x H 270mm

Liquid:	Electrical data:
Liquid Type: Clean Water Clean water temperature range: 2 – 85°C	Rated voltage: 220V(-6%) - 240V(+6%) Mains frequency: 50Hz P2(kW): 1.1 (Shaft Power) Current: 5.8 amps Capacitor: 30 uF Motor duty: Continuous Motor type: Asynchronous, TEFC Motor Protection: In-built thermal overload
Materials:	Hydraulic Data:
Pump Body: Stainless Steel 304 Impeller: Stainless Steel 304 O rings: Nitrile Power Cable: 2m cable H07 3G1.0	Max Head: 30m Max Flow: 204 l/min
Installation:	Ingress protection: IP X4 Insulation class: F
Maximum ambient temperature: 40°C Maximum operating pressure: 8 bar Pipe connections suction/discharge: 1¼" BSPF / 1" BSPF	

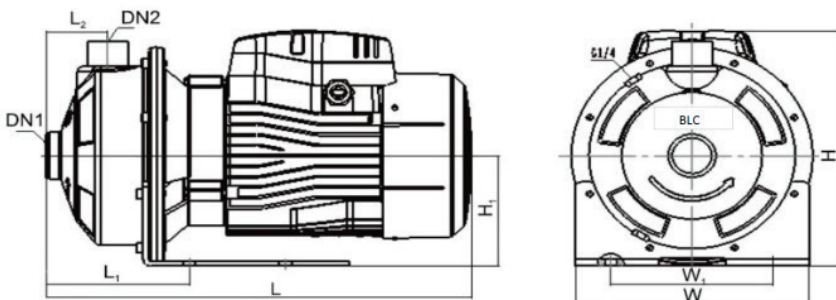

DN1	DN2	L (mm)	W (mm)	H (mm)	LI (mm)	L2 (mm)	W1 (mm)	H1 (mm)
1-1/4"	1"	381	210	234	109	55	150	110

