

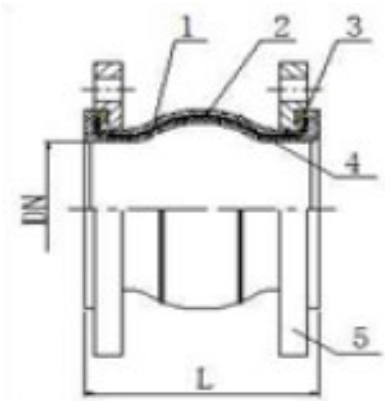



RUBBER BELLOWS



GVF CODE	DN SIZE	LENGTH					WEIGHT (kg)
			ELONGATION	COMPRESSION	LATERAL DISPLACEMENT	ANGLE OF DEFLECTION	
RBE025	25	95	6	9	9	15°	2
RBE032	32	95	6	10	9	15°	2.3
RBE040	40	105	6	10	9	15°	2.75
RBE050	50	115	7	10	10	15°	3
RBE065	65	135	8	13	12	15°	4.1
RBE080	80	150	8	15	12	15°	5.2
RBE100	100	165	12	19	15	15°	6
RBE125	125	180	12	19	15	15°	10.3
RBE150	150	190	12	20	15	10°	11.6
RBE200	200	230	12	20	22	10°	16
RBE250	250	245	16	28	22	10°	24
RBE300	300	265	16	28	25	10°	27
RBE350	350	265	16	28	25	10°	41
RBE400	400	265	16	28	25	10°	50
RBE450	450	265	16	28	25	10°	80
RBE500	500	265	16	28	25	10°	75
RBE600	600	265	16	28	25	10°	120

MATERIALS

Outer Rubber	EPDM
Cord Fabric	Nylon
Steel Wire	Steel
Inner Rubber	EPDM
Flange	HDG Steel

SPECIFICATIONS

Working Temperature	-15°c to 115°c
Cold Working Pressure	1600kpa

STANDARD

Flanges	AS2129/TE
---------	-----------