

4" WATER LUBRICATED REWINDABLE MOTORS

TECHNICAL SPECIFICATIONS:

- 4" Water Lubricated Motors are rewindable.
- Coupling dimensions as per NEMA standard.
- Winding wire : Polywrapped.
- Degree of protection : IP68.
- Max water temperature : 35° C.
- Start per hour : 30 time (Max.).
- Allowable voltage variation +6% - 10%.
- Motor shaft of Stainless Steel.
- Stator shell of Stainless Steel.
- Max depth immersion : 250 M.
- Mounting : vertical / horizontal.
- Upper / Lower bracket in Cast Iron with Epoxy Paint OR
- Upper Bracket Steel Cast/ Lower bracket with SS Cladding.
- Single Phase Motors are Capacitor start and run.
- Motor Cable length : 3 Meter (3 Core / 4 Core).
- Coolant : Clear Water.

VERSIONS:

Single Phase : 0.37 kW to 4.00 kW, 220 - 230Volt / 50 Hz.

0.37 kW to 4.00 kW, 230Volt / 60 Hz.

Three Phase : 0.55 kW to 7.50 kW, 380 - 415Volt / 50 Hz.

0.37 kW to 7.50 kW, 230 - 380 - 460Volt /60 Hz.

Motors with other Voltage and frequency ratings are also available on specific demand.

4" W/L REWINDABLE MOTOR

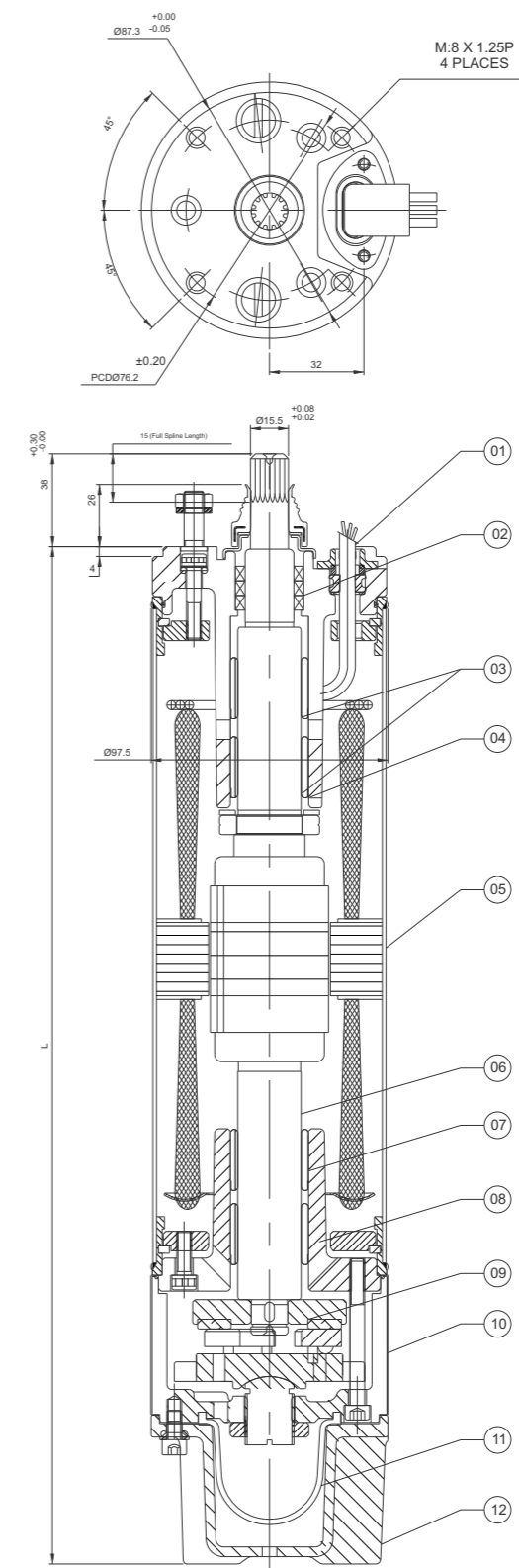

Technical Data of 4" Motors Single Phase (220-230 Volt / 50 Hz) CSR

SR NO.	PARTS NAME	MATERIAL
01	CABLE 3 CORE/4 CORE	EPR
02	OIL SEAL	N.B.R
03	BEARING BUSH	CARBON
04	UPPER HOUSING	S.S.304/ CAST IRON (F.G.200) / CLADED
05	MOTOR SHELL	S.S.304
06	ROTOR SHAFT	S.S.431
07	BEARING BUSH	CARBON
08	LOWER HOUSING	CAST IRON (FG-200)
09	THRUST BEARING SET	CARBON / S.S.420
10	LOWER PART-2	CAST IRON / CLADED
11	PRESSURE CUP	HBR
12	MOTOR BASE	S.S.304/CAST IRON (F.G.200)
13	ALL HARDWARE	S.S.304

PN		Thrust Load [N]	UN [V]	nN [min-1]	IN [A]	IA [A]	h [%]			cos j			TN [Nm]	TA [Nm]	Capacitor Running F (Uc=450V)
[H.P.]	[kW]						50	75	100	50	75	100			
0.50	0.37	1500	220	2855	3.21	10.6	37	49	56	0.89	0.93	0.96	1.21	0.93	72
			230	2860	3.40	11.3	36	47	54	0.82	0.84	0.93	1.21	1.02	
0.75	0.55	1500	220	2845	4.19	15.38	47	58	64	0.91	0.94	0.97	1.86	1.28	72
			230	2855	4.29	16.11	46	57	64	0.82	0.91	0.93	1.86	1.42	
1.00	0.75	1500	220	2845	5.79	20.21	45	56	61	0.95	0.98	0.99	2.45	1.99	72
			230	2855	5.70	21.10	43	53	61	0.91	0.96	0.98	2.45	2.19	
1.50	1.10	3000	220	2850	8.41	30.11	47	58	64	0.91	0.95	0.98	3.70	2.81	72
			230	2855	8.58	31.50	44	54	63	0.82	0.90	0.95	3.70	3.10	
2.00	1.50	3000	220	2805	10.59	33.91	52	62	68	0.92	0.95	0.98	4.97	3.28	72
			230	2825	10.59	35.38	50	59	67	0.81	0.90	0.96	4.97	3.62	
3.00	2.20	4000	220	2815	16.00	54.1	52	60	64	0.95	0.96	0.99	7.41	4.37	108
			230	2840	15.51	56.6	51	62	66	0.85	0.92	0.97	7.41	4.82	
4.00	3.00	4000	220	2810	20.1	72	55	61	66	0.94	0.96	0.96	10	6	108
			230	2830	20.0	74	52	61	67	0.85	0.93	0.97	9.94	6.5	
5.50	4.00	4000	220	2815	25.5	92.0	55	62	67	0.95	0.96	0.97	13.7	8.90	108
			230	2830	25.2	95.7	53	62	67	0.86	0.94	0.98	13.6	8.98	

PN		PW L [mm]	MOTOR WEIGHT [kg]		MOTOR WEIGHT (incl.pkg) [kg]	
[kW]	[HP] (S.P)		C.I. / S.S.	S.S. 304	Cast Iron	S.S. 304
0.37	0.50	526	12.0	12.2	13.8	15.7
0.55	0.75	526	12.0	12.2	13.8	15.7
0.75	1.00	541	12.5	12.6	14.2	16.2
1.10	1.50	556	12.8	13.2	14.7	16.7
1.50	2.00	641	20.6	21.7	23.7	24.0
2.20	3.00	691	23.2	24.3	26.0	27.0
3.70	5.00	911	36.2	38.4	40.5	42.0

Technical Data of 4" Motors Single Phase (220-230 Volt / 50 Hz) CSCR

PN		PW L [mm]	MOTOR WEIGHT [kg]		MOTOR WEIGHT (incl.pkg) [kg]	
[kW]	[HP] (T.P)		C.I. / S.S.	S.S. 304	Cast Iron	S.S. 304
0.37	0.50	566	12.9	13.2	15.0	17.0
0.55	0.75	566	12.9	13.2	15.0	17.0
0.75	1.00	601	16.9	17.2	20.2	22.2
1.10	1.50	601	16.9	17.2	20.2	22.2
1.50	2.00	621	20.0	21.0	23.0	24.0
2.20	3.00	671	22.5	23.6	25.2	26.2
3.70	5.00	771	33.5	35.4	38.0	39.0
5.50	7.50	911	36.2	38.4	40.5	43.0
7.50	10.00	966	38.4	40.7	42.9	45.6

PN		Thrust Load [N]	UN [V]	nN [min-1]	IN [A]	IA [A]	h (Eff.) [%] at % load			cos j (PF) at % load			TN [Nm]	TA [Nm]	Capacitor Running nF (Uc=450V)	Capacitor Starting nF (Uc=270V)
[H.P.]	[kW]						50	75	100	50	75	100				
0.50	0.37	1500	220	2890	4.21	15.11	50	60	62	0.51	0.64	0.74	1.21	2	72	100-120
			230	2890	4.00	14.30	50	60	62	0.51	0.64	0.74	1.21	2		
0.75	0.55	1500	220	2895	6.29	24.11	51	59	63	0.49	0.60	0.69	1.79	2.7	72	100-120
			230	2895	6.00	23.00	51	59	63	0.49	0.60	0.69	1.79	2.7		
1.00	0.75	1500	220	2890	7.59	29.5	55	63	64	0.55	0.66	0.76	2.51	4.1	72	100-120
			230	2890	7.31	28.2	55	63	64	0.55	0.66	0.76	2.51	4.1		
1.50	1.10	3000	220	2890	9.58	41.3	57	66	68	0.58	0.72	0.80	3.69	6.0	72	100-120
			230	2890	8.90	39.5	57	66	68	0.58	0.72	0.80	3.69	6.0		
2.00	1.50	3000	220	2880	11.58	55.7	61	67	68	0.70	0.82	0.88	4.89	8.28	72	100-120
			230	2880	11.10	53.5	61	67	68	0.70	0.82	0.88	4.89	8.28		
3.00	2.20	4000	220	2885	16.71	83	62	68	70	0.71	0.81	0.88	7.41	14	108	120-150
			230	2885	15.89	87	62	68	70	0.71	0.81	0.88	7.41	14		
4.00	3.00	4000	220	2885	20.6	103	62	68	71	0.73	0.82	0.88	9.75	18.5	108	120-150
			230	2885	20.3	112	62	68	71	0.73	0.82	0.88	9.75	18.5		
5.50	4.00	4000	220	2885	25.8	129	63	69	71	0.74	0.82	0.89	13.4	24.1	108	120-150
			230	2885	25.6	141	63	69	71	0.74	0.82	0.89	13.4	24.1		

- PN - Rated Output
- UN - Rated Voltage
- nN - RPM
- IN - Full Load Current
- IA - Starting Current
- h - Motor Efficiency
- cos j - Power Factor
- TN - Full Load Torque
- TA - Starting Torque
- F{N}- Axial Thrust Load

Technical Data of 4" Motors Three Phase (380-415 Volt / 50 Hz)

PN		Thrust F [N]	UN [V]	nN [min-1]	IN [A]	IA [A]	h (Eff.) [%] at % load			cos j (PF) at % load			TN [Nm]	TA [Nm]
[H.P.]	[kW]						50	75	100	50	75	100		
0.75	0.55	1500	380	2835	1.59	6.00	60	66	67	0.60	0.72	0.81	1.89	3.11
			400	2855	1.59	6.38	58	65	67	0.54	0.68	0.75	1.89	3.51
			415	2875	1.70	6.61	55	64	66	0.50	0.64	0.80	1.89	3.70
1.00	0.75	1500	380	2845	2.11	8.88	64	67	70	0.58	0.71	0.79	2.50	4.81
			400	2870	2.11	9.30	60	68	69	0.51	0.64	0.75	2.50	5.32
			415	2880	2.20	9.81	58	65	68	0.49	0.61	0.72	2.50	5.89
1.50	1.10	3000	380	2825	3.00	13.70	68	72	73	0.58	0.72	0.81	3.79	9.61
			400	2840	3.00	14.51	67	71	73	0.53	0.67	0.75	3.69	10.60
			415	2860	3.11	15.28	65	70	72	0.50	0.62	0.72	3.69	11.49
2.00	1.50	3000	380	2845	3.91	18.59	68	72	73	0.60	0.72	0.81	5.0	11.31
			400	2855	4.00	19.21	66	72	73	0.54	0.66	0.77	5.0	12.60
			415	2870	4.10	20.21	64	70	72	0.49	0.62	0.73	4.9	13.49
3.00	2.20	4000	380	2820	5.80	28.68	71	75	75	0.59	0.72	0.81	7.59	21.71
			400	2840	5.91	28.90	70	73	75	0.51	0.65	0.76	7.51	23.61
			415	2870	6.29	30.78	66	71	74	0.46	0.60	0.69	7.51	25.90
4.00	3.00	4000	380	2810	8.5	29.5	62	67	70	0.72	0.78	0.82	10	16
			400	2820	8.2	31.0	61	66	68	0.71	0.77	0.80	9.97	17.95
			415	2850	8.0	33.0	60	65	67	0.70	0.76	0.80	9.87	18.75
5.50	4.00	4000	380	2790	10.79	32.29	62	67	71	0.72	0.79	0.83	13.39	21.25
			400	2790	10.51	34.00	61	65	69	0.70	0.76	0.82	13.30	23.54
			415	2810	10.0	35.00	59	64	66	0.69	0.74	0.82	13.30	25.29
7.50	5.50	4000	380	2785	14.79	50.4	69	73	74	0.74	0.79	0.84	18.93	37.19
			400	2790	14.51	53.0	68	72	73	0.74	0.79	0.84	18.92	41.21
			415	2810	14.00	54.9	67	69	71	0.73	0.77	0.83	18.81	44.35
10.0	7.50	4000	380	2855	18.00	61.1	70	72	73	0.98	0.95	0.92	24.58	45.10
			400	2860	18.31	62.0	67	71	72	0.99	0.94	0.91	24.51	46.00
			415	2880	18.79	65.9	66	68	70	0.97	0.92	0.88	24.40	47.51

- PN - Rated Output
- UN - Rated Voltage
- nN - RPM
- IN - Full Load Current
- IA - Starting Current
- h - Motor Efficiency
- cosj - Power Factor
- TN - Full Load Torque
- TA - Starting Torque
- F(N) - Axial Thrust Load

Technical Data of 4" Motors Single Phase / 60 Hz (CSR)

PN		Thrust Load [N]	UN [V]	nN [min-1]	IN [A]	IA [A]	h (Eff.) [%] at % load			cos j (PF) at % load			TN [Nm]	TA [Nm]	Capacitor Running nF (Uc=450V)
[H.P.]	[kW]						50	75	100	50	75	100			
0.5	0.37	3000	230	3450	4.2	10.7	43	53	60	0.76	0.79	0.88	1.02	0.86	72
0.75	0.55	3000	230	3450	5	15.4	50	60	67	0.83	0.91	0.95	1.53	1.16	72
1.0	0.75	3000	230	3460	7	20.2	46	55	62	0.90	0.95	0.98	2.03	1.81	72
1.5	1.1	3000	230	3450	9.5	30.1	49	59	67	0.81	0.88	0.93	3.06	2.57	72
2.0	1.5	3000	230	3450	12	33.9	53	63	70	0.83	0.91	0.96	4.07	2.97	72
3.0	2.2	4000	230	3430	16	54.2	58	68	73	0.87	0.94	0.98	6.15	4.00	108

- PN - Rated Output
- UN - Rated Voltage
- nN - RPM
- IN - Full Load Current
- IA - Starting Current
- h - Motor Efficiency
- cosj - Power Factor
- TN - Full Load Torque
- TA - Starting Torque
- F(N) - Axial Thrust Load

Technical Data of 4" Motors Single Phase / 60 Hz (CSCR)

PN		Thrust Load [N]	UN [V]	nN [min-1]	IN [A]	IA [A]	h (Eff.) [%] at % load			cos j (PF) at % load			TN [Nm]	TA [Nm]	Capacitor Running nF (Uc=450V)	Capacitor Starting nF (Uc=270V)
[H.P.]	[kW]						50	75	100	50	75	100				
0.5	0.37	3000	230	3480	4.2	15.2	57	64	67	0.50	0.59	0.68	1.01	1.68	72	100-120
0.75	0.55	3000	230	3485	6.5	24.2	57	65	68	0.49	0.59	0.70	1.51	2.27	72	100-120
1.0	0.75	3000	230	3490	7.8	30	54	62	65	0.53	0.64	0.73	2.01	3.3	72	100-120
1.5	1.1	3000	230	3490	9.6	41.5	60	67	70	0.59	0.70	0.79	3.04	4.92	72	100-120
2.0	1.5	3000	230	3480	12.5	55.3	63	71	74	0.69	0.80	0.89	4.04	6.87	72	100-120
3.0	2.2	4000	230	3475	16.5	82	67	74	77	0.70	0.81	0.89	6.07	11.5	108	120-150
5.5	4.0	4000	230	3450	26.0	130	68	74	77	0.70	0.82	0.98	11.2	21.2	108	200-250

- PN - Rated Output
- UN - Rated Voltage
- nN - RPM
- IN - Full Load Current
- IA - Starting Current
- h - Motor Efficiency
- cosj - Power Factor
- TN - Full Load Torque
- TA - Starting Torque
- F(N) - Axial Thrust Load

Exploded Drawing of 4" WL Motor

Technical Data of 4" Motors Three Phase / 60 Hz

PN		Thrust Load [N]	UN [V]	nN [min-1]	IN [A]	IA [A]	h (Eff.) [%] at % load			cos j (PF) at % load			TN [Nm]	TA [Nm]
[H.P.]	[kW]						50	75	100	50	75	100		
0.5	0.37	3000	230	3445	2.41	9.6	59	62	64	0.58	0.71	0.79	1.02	1.84
			380	3445	1.42	5.6	59	62	64	0.58	0.71	0.79	1.02	1.96
			460	3445	1.21	4.8	59	62	64	0.58	0.71	0.79	1.02	2.24
0.75	0.55	3000	230	3450	3.10	12.4	63	67	69	0.57	0.71	0.80	1.53	2.3
			380	3450	1.91	7.6	63	67	69	0.57	0.71	0.80	1.53	2.5
			460	3450	1.60	6.4	63	67	69	0.57	0.71	0.80	1.53	2.75
1.0	0.75	3000	230	3455	3.91	17.55	65	68	70	0.59	0.72	0.81	2.03	3.55
			380	3455	2.32	10.35	65	68	70	0.59	0.72	0.81	2.03	3.9
			460	3455	2.00	9	65	68	70	0.59	0.72	0.81	2.03	4.47
1.5	1.1	3000	230	3445	5.00	25	70	73	76	0.61	0.76	0.83	3.04	6.69
			380	3445	3.00	15	70	73	76	0.61	0.76	0.83	3.04	7.7
			460	3445	2.51	12.5	70	73	76	0.61	0.76	0.83	3.04	8.2
2.0	1.5	3000	230	3445	6.71	33.5	64	66	69	0.59	0.73	0.81	4.08	8.16
			380	3445	4.11	20.5	64	66	69	0.59	0.73	0.81	4.08	9.22
			460	3445	3.40	17	64	66	69	0.59	0.73	0.81	4.08	10.2
3.0	2.2	4000	230	3450	9.51	47.5	70	73	75	0.52	0.65	0.74	6.11	15.3
			380	3450	5.80	29	70	73	75	0.52	0.65	0.74	6.11	17.4
			460	3450	4.82	24	70	73	75	0.52	0.65	0.74	6.11	18.33
5.5	4.0	6500	230	3450	15.91	55.65	69	71	74	0.52	0.66	0.75	11.2	15.70
			380	3450	9.62	33.6	69	71	74	0.52	0.66	0.75	11.2	17.70
			460	3450	8.00	28	69	71	74	0.52	0.66	0.75	11.2	19.04
7.5	5.5	6500	230	3445	23.0	92	71	73	76	0.56	0.68	0.77	15.30	22.95
			380	3445	13.91	55.6	71	73	76	0.56	0.68	0.77	15.30	30.00
			460	3445	11.51	46	71	73	76	0.56	0.68	0.77	15.30	33.70
10.0	7.5	6500	230	3450	27.1	95	70	73	75	0.58	0.71	0.80	20.4	32.64
			380	3450	19.29	67.55	70	73	75	0.58	0.71	0.80	20.4	37.33
			460	3450	15.91	55.65	70	73	75	0.58	0.71	0.80	20.4	44.90

- PN - Rated Output
- UN - Rated Voltage
- nN - RPM
- IN - Full Load Current
- IA - Starting Current
- h - Motor Efficiency
- cosj - Power Factor
- TN - Full Load Torque
- TA - Starting Torque
- F(N) - Axial Thrust Load

