

**Floatless
RainBank
Available
NOW**

APPLICATIONS

RainBank is ideal for metropolitan rainwater harvesting on homes, toilet blocks and garden irrigation.



Surface Mounted Models Submersible (in tank) Models



Rainwater Harvesting Controller

Model Numbers:

KRB1, KRB2, KRB1NF, KRB2NF, KRB3, KRB4, KRBX1, KRBS1, KRBS2, KRBSA1

Dual source controller, specifically designed to source rainwater for water applications such as toilets and/or laundry, with automatic mains water back-up. Also suitable for exterior taps.

Option of Floatless, surface mounted and submersible “in tank” pump options for installation convenience.



WHY CHOOSE THE DAVEY RainBank CONTROLLER?

- RainBank is a mains/tank water interconnection device sourcing rainwater as a priority with mains as a back up
- New Floatless version now available
- Unique patented, yet uncomplicated technology, providing a dependable solution to rainwater harvesting.
- Environmentally friendly:
 - Saving water
 - Reduced inflow to stormwater systems
 - No re-pumping of mains water
 - Low power consumption in standby
- No solenoid valves used
- Provides seamless mains back-up in the event of no rainwater or electrical interruptions, for consumer convenience and comfort.
- Feedback lights to indicate water source and faults.
- Built-in backflow protection valve (dual check valve) in compliance with the requirements of AS/NZS 3500-1-2003 for added safety and assured protection of your mains water supply.
- Can be mounted on pump or on nearby wall for easier installation and to suit a variety of applications. Best mounted near the laundry and away from bedrooms.
- Simple to install with no adjustment necessary, saving time and money at installation.
- Yellow LED – fault condition

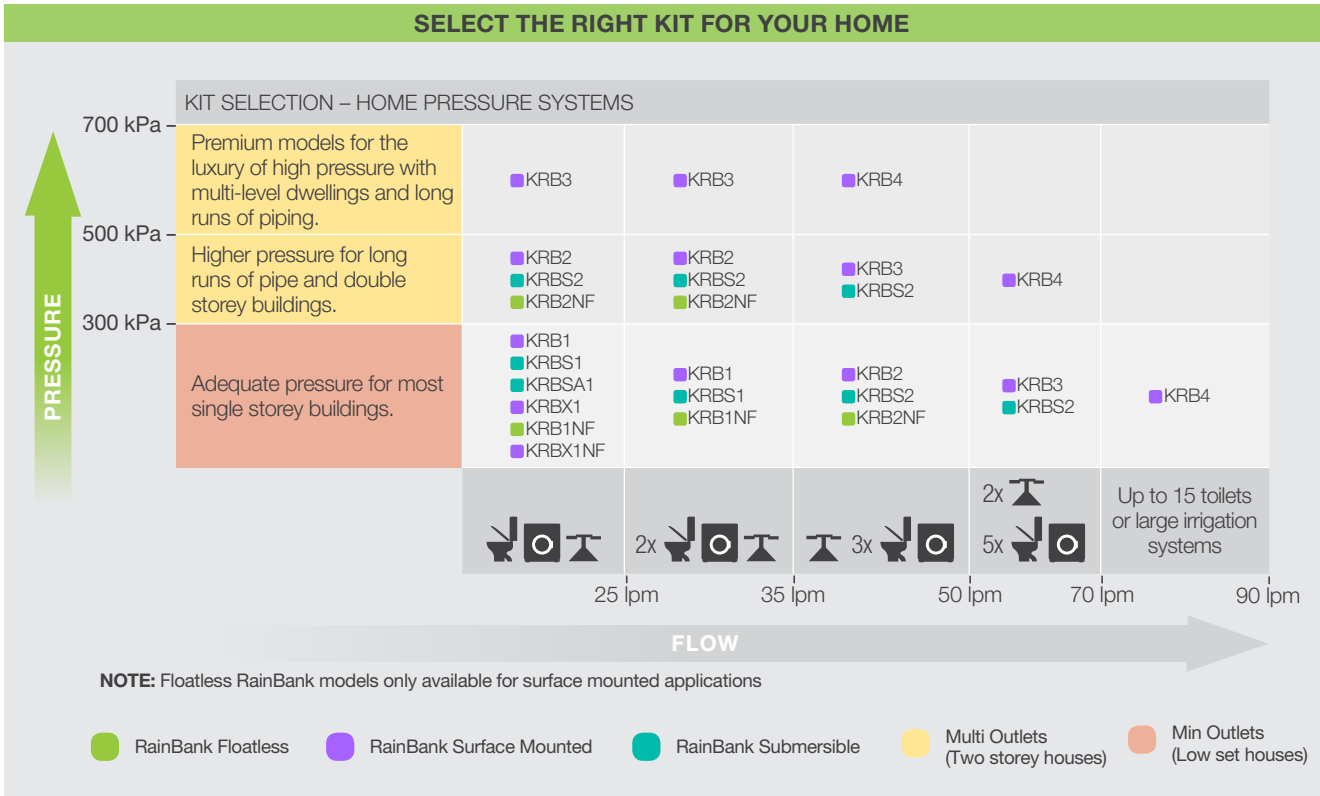

| | RainBank Model | Pump Model | Float Type | Flow Rate @200kPa | Higher Pressure | Higher Flows |
|-------------|------------------------------|-------------------|------------|-------------------|-----------------|--------------|
| | Surface Mounted – Floatless | | | | | |
| | KRB1NF | HP45-05 | Floatless | 40 lpm | ✗ | ✗ |
| | KRB2NF | HS50-06 | Floatless | 46 lpm | ✓ | ✓ |
| | Surface Mounted – Top Entry | | | | | |
| | KRBX1 | SJ35-04 | Top Entry | 25 lpm | ✗ | ✗ |
| | KRB1 | HP45-05 | Top Entry | 40 lpm | ✗ | ✗ |
| | KRB2 | HS50-06 | Top Entry | 46 lpm | ✓ | ✓ |
| | KRB3 | HM60-08* | Top Entry | 60 lpm | ✓ | ✓ |
| | KRB4 | HM90-13* | Top Entry | 80 lpm | ✓ | ✓ |
| | Surface Mounted – Side Entry | | | | | |
| KRBX1F | SJ35-04 | Side Entry | 25 lpm | ✗ | ✗ | |
| KRB1F | HP45-05 | Side Entry | 40 lpm | ✗ | ✗ | |
| KRB2F | HS50-06 | Side Entry | 46 lpm | ✓ | ✓ | |
| Submersible | | | | | | |
| KRBSA1 | D23A/B | Submersible Float | 10 lpm | ✗ | ✗ | |
| KRBS1 | D42A/B | Submersible Float | 40 lpm | ✗ | ✗ | |
| KRBS2 | D53A/B | Submersible Float | 63 lpm | ✓ | ✓ | |

NOTE: HM models are suited to flooded suction applications

FLOATLESS MODELS FEATURE:

- > Benefit of a mains switching device without having to worry about a float
- > Float can be easily be added if the application requires it
- > Suited to flooded suction applications

Install it like this

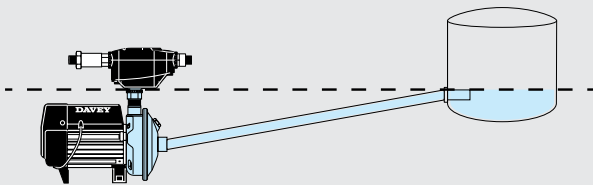

SUBMERSIBLE 'IN TANK' MODELS FEATURE:

- > Quieter running that can be a concern with smaller domestic lot sizes
- > Pump can not be tampered with by children or pets

Install it like this

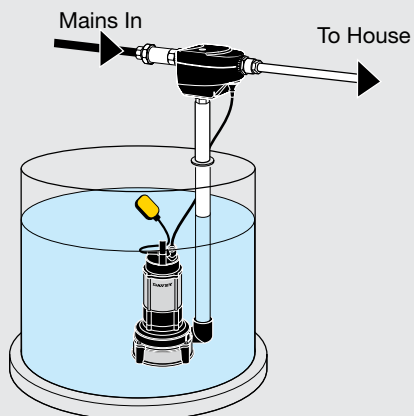

SURFACE MOUNTED MODELS FEATURE:

- > Higher pressure options and flow rates
- > Option of top entry or side entry float
- > Easy system access for maintenance and servicing
- > In the event of a leak, this can be easily identified

Install it like this

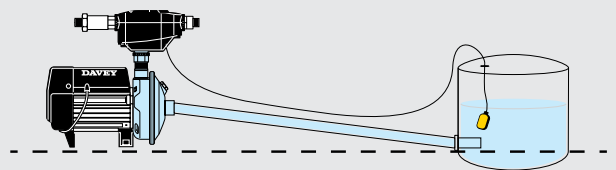

OR

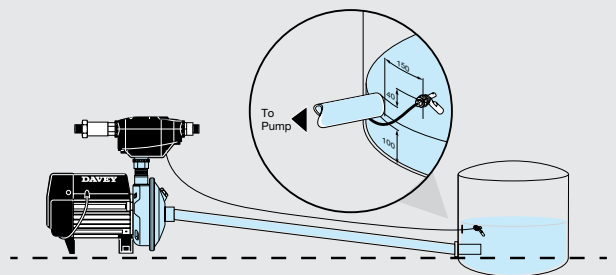

OR

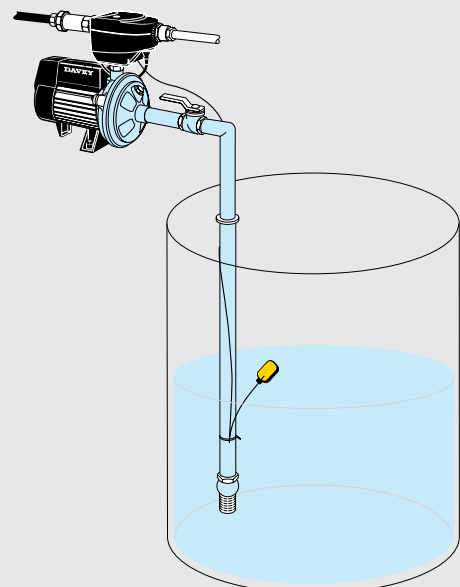

OPERATING LIMITS

| | |
|--------------------------------------|-------------|
| Maximum flow rate (mains) | 100 lpm |
| Maximum flow rate (pump) | 100 lpm |
| Maximum mains water pressure | 900 kPa |
| Maximum pump pressure | 600 kPa |
| Maximum pump amps | 10 amps |
| Level switch voltage | 12 volts DC |
| Maximum water temperature continuous | 50°C |
| Minimum water temperature | 1°C |
| Maximum ambient temperature | 50°C |
| Mains water inlet size | 3/4" BSP(M) |
| Rainwater inlet size | 1" BSP(M) |
| Outlet size | 3/4" BSP(M) |

NOTE: RainBank/S model specifically designed for submersible pumps fitted with auto float switch.

MATERIALS OF CONSTRUCTION

| PART | MATERIAL |
|-----------------------------|---------------------|
| Dual check valve | |
| Body | D.R. brass |
| Valves | Acetal |
| Springs | 304 stainless steel |
| Source control valve | |
| Body | Nylon |
| Valves | Acetal |
| Plunger | Grivory |
| Diaphragm | Santoprene |
| Springs | 316 stainless steel |
| Seal | Nitrile |
| Sensor plate | 316 stainless steel |
| Enclosure | A.B.S. |

ELECTRICAL DATA

| | |
|------------------------------|----------|
| Supply voltage | 220-250V |
| Supply frequency | 50Hz |
| Max. full load current | 10A |
| Enclosure class | IP23 |
| Power supply lead – incoming | 2m |
| Level switch lead length: | |
| Side entry | 5m |
| Top entry | 9m |

NOTE: Refer to relevant pump datasheets for technical pump data

APPROVALS

Complies with electrical standards: **AS/NZS60335.2.41: 2004 Clause 24**

Certificate of electrical suitability: **A/10E**

Complies with plumbing standards: **AS/NZS3500-1-2003** including provision of backflow protection when installed in compliance with product Installation & Operating Instructions.

Watermark License **WMKA22042**.

Must be installed by a licensed plumber.

HYDRAULIC PERFORMANCE & DIMENSIONS (mm)

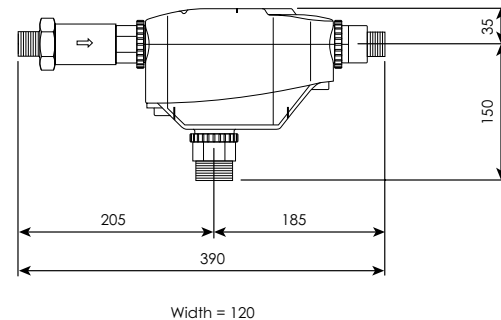
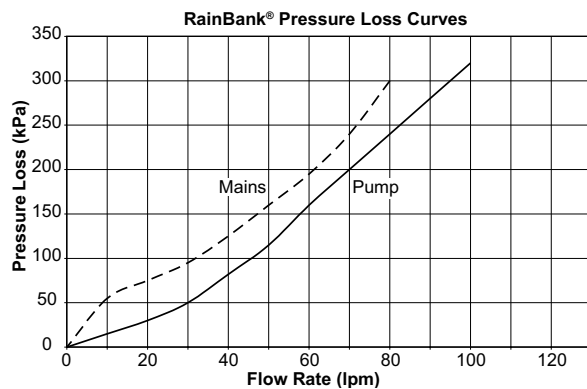
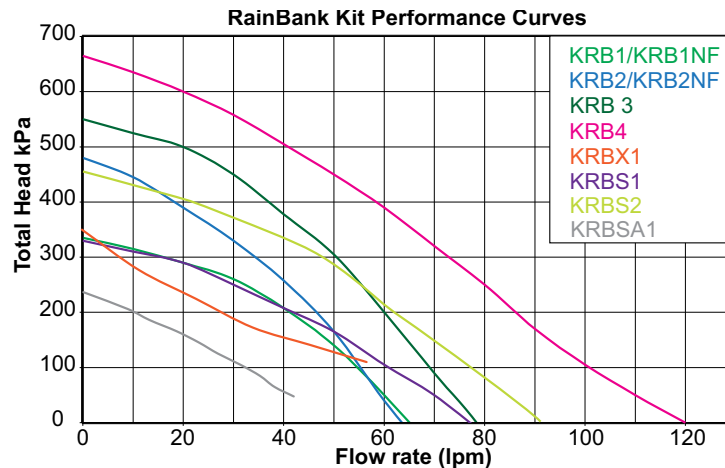

NOTE: Optional bracket available on request. P/N 32556