

GENERAL INFO

SPECIFICALLY DESIGNED FOR RAINWATER SUPPLY

Provides safe and bacteria-free water for your whole house.

The Puretec WU-UV Series systems are a filtration and ultraviolet all-in-one unit with a reversible mounting frame. These economical systems are designed for both mains and rainwater supplies, and effectively eliminate 99.9% of bacteria in your water including E. coli. They can be installed from left to right or right to left depending on the water supplies point of entry. Enjoy the peace of mind knowing you have safe, purified water at every outlet in the house.

FEATURES & BENEFITS

- Quick and easy plug-and-play installation.
- Reversible mounting frame for easy installation.
- Kills 99.9% of E.coli, Giardia and Cryptosporidium cysts utilising Puretec's ultraviolet technology, a natural process that's completely eco-friendly and chemical-free.
- Filtration and ultraviolet all-in-one unit.
- Turns your tank and/or mains water into pure, safe, delicious drinking water.
- Made from lightweight, durable materials.
- Equipped with a lamp count-down timer and failure alarm (audible & visible).



WU-UV100

10", 1" connection,
NZ Model



WU-UV150

20", 1" connection,
AU Model



WU-UV200

20", 1" connection,
NZ Model



WU-UV250

20", 1" connection,
AU Model

TECHNICAL DATA

Ordering Code	WU-UV100 (NZ)	WU-UV150 (AU)	WU-UV200 (NZ)	WU-UV250 (AU)
Replacement parts and cartridges:				
Stage 1 filtration:	PP20LD1	PP05LD1	PP20LD2	PP05LD2
Stage 2 filtration:	MB01LD1	ML10LD1-DP	MB01LD2	ML10LD2-DP
UV lamp, 46W	RL6			
Quartz sleeve:	RQ56			
Power supply:	220-240 VAC / 50 Hz			
Water temperature range:	0-52°C (protect from freezing)			
Supply pressure:	300 - 520 kPa (Install Pressure Limiting Valve if pressure exceeds 520 kPa)			
UV dosage @40mJ/cm2:	54 Lpm			
UV dosage @30mJ/cm2:	70 Lpm			
UV dosage @16mJ/cm2:	130 Lpm			
Flow rate:	60 Lpm	60 Lpm	110 Lpm	110 Lpm
Connection:	1" BSP [25mm]			
Warranty:	1 year^			

Important Note: Use only genuine Puretec replacement cartridge. Flow rate @30mJ/cm² is the industry standard for drinking water.

ADDITIONAL INFORMATION

Where the water being treated contains unusually high levels of dissolved solids particularly hard water, iron, manganese or biological organisms, a deposit build-up on the quartz sleeve may occur over time. Maximum recommended parameters are as follows:

Iron:	less than 0.3 mg/L
Hydrogen Sulfide:	less than 0.05 mg/L
Suspended Solids:	less than 10mg/L
Manganese:	less than 0.05 mg/L
Hardness:	less than 110mg/L

Important Note: These systems need to be installed where it is protected from the weather and outside elements. For outdoor installation, see the Puretec HybridPlus & Hybrid G Series.

DIAGRAM & FILTRATION TECHNOLOGY

The Puretec WU-UV Series systems are an economical filtration and ultraviolet all-in-one unit with a reversible mounting frame that effectively eliminate 99.9% of bacteria in your water. Ensuring you always have safe and pure water at every outlet.

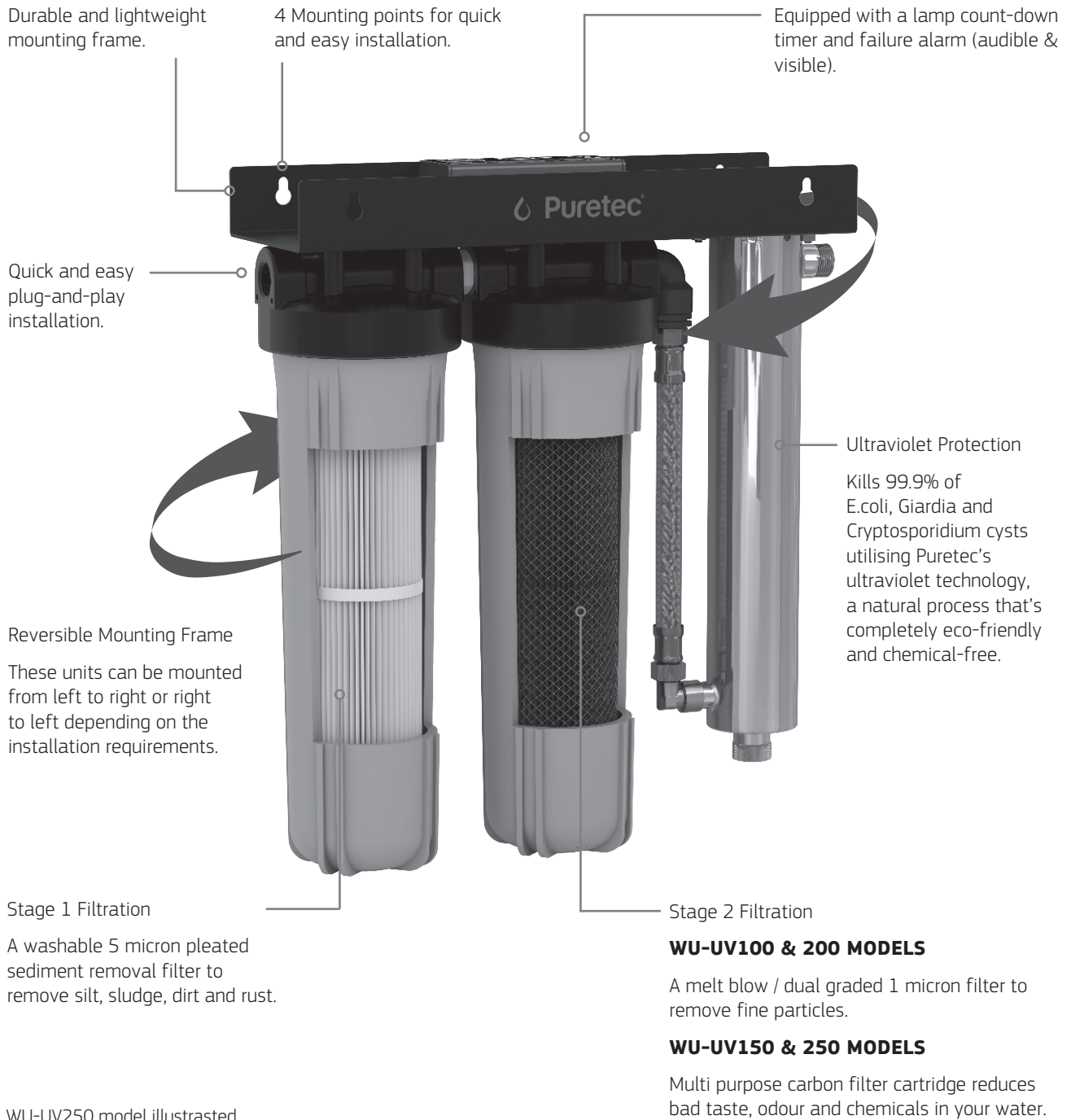

PRODUCT DIMENSIONS Measurements in Millimeters (mm)

WU-UV100 & 150 MODELS

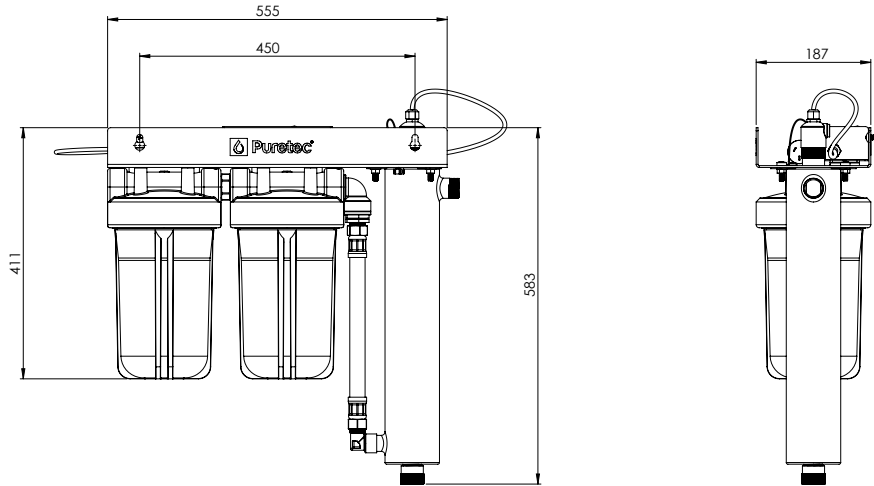

WU-UV200 & 250 MODELS

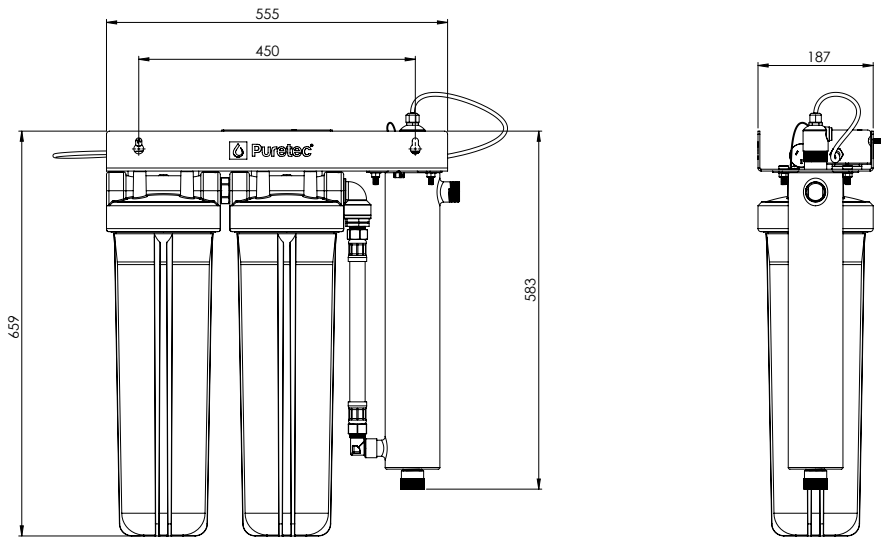

Note:

1. No claims can be made based on the specifications and images in this document. The design, technology, colours, features and prices are subject to change.
2. This document and all its contents are copyright protected. All rights are reserved, particularly alteration, translation and reproduction using electronic systems.
3. ^Warranties in this document cover parts for 1 year and include cover for parts and labour where applicable, subject to approval.

Our Water Filtration Specialists can provide you with advice to suit your needs.