

PSk3-7 to PSk3-15

Hybrid Solar Pumping System

Manual for Installation and Operation

Manuel d'installation et d'utilisation

Manual de instalación y operación

EN

photo may differ from actual product



Table of Content

1	Introduction	4
2	Installation overview	5
2.1	Registration of components	6
2.2	PV and Controller Installation.	6
2.3	Electrical installation.	6
2.4	Pump Installation	7
2.5	Feature configuration with LORENTZ Assistant.	8
3	PSk3 and LORENTZ Assistant	10
4	Product Information	11
4.1	Product Description	11
4.2	Technical Data of the PSk3 Controller	12
4.3	Technical requirements for the pumps	13
4.4	Naming convention	14
4.5	Storage of pump system components.	15
4.6	Scope of delivery	15
5	Safety Instructions	16
6	Pump System Sizing & Layout Diagrams.	18
6.1	Pump System Sizing	18
6.2	System Layout: Submersible Pumps	20
6.3	System Layout: Surface Pumps	21
6.4	Solar-diesel system sizing considerations	22
7	Controller Installation	25
7.1	Controller Elements	25
7.2	Controller Placement	25
7.3	Mounting, Space and Ventilation Requirements	27
7.4	Wiring the controller.	28
7.5	Grounding	46
8	Pump Installation	49
8.1	General instructions.	49
8.2	Submersible Pumps	51
8.3	Surface Pumps	63
9	Pump Accessories Installation	71
9.1	Well probe	71
9.2	Water detection sensor	73
9.3	Water meter installation	77
9.4	Level sensor installation	77
9.5	Water Level Management Solution (WLMS) installation	77
9.6	Pressure sensor installation	78

9.7	Float Switch (Full Tank Shut-off).	79
9.8	Sacrificial Anode	80
9.9	PV Disconnect 1000-40-5	80
9.10	PV Combiner 1000-125-4 for PSk3-7 to PSk3-15	82
9.11	PV Protect 1000-125 for PSk3-7 to PSk3-15.	82
9.12	SmartStart	83
10	Operating the Pump	87
10.1	LED Status	88
10.2	Starting the pump	90
10.3	Time delays.	90
10.4	Parameter settings	91
11	LORENTZ CONNECTED	92
11.1	PSk3 data access and data logging	92
11.2	LORENTZ Assistant	92
11.3	LORENTZ Global & PS Commander	93
12	Troubleshooting.	94
12.1	Pump does not run	94
12.2	Pump attempts a restart every 4 minutes	95
13	Service and Maintenance	97

1 Introduction

Thank you for purchasing a LORENTZ pump system. With PSk3, LORENTZ has set a new standard for quality, efficiency and durability in solar pumping.

Before you begin: All pump systems are equipped with nameplates, which contain all important data. Check the model numbers of all the components of your system, verify that they are the items that you ordered and ensure that the packaging is undamaged and complete. To allow best system performance and to avoid damage, read and follow the installation instructions carefully.

How to use this guide: This manual is for system installation only, follow it closely for a safe installation. The system layout must be planned beforehand. We advise using the LORENTZ COMPASS software for correct pump system sizing.

Sites: It is mandatory to register the installation at "Sites" in LORENTZ partnerNET. Sites provides an easy overview of all installed pump systems, including serial numbers and installation details. This will be essential information should problems occur and will simplify trouble shooting and warranty topics. You are also able to register a Site using LORENTZ Assistant. Please refer to the LORENTZ Assistant manual for more information.

2 Installation overview

This installation overview is provided to familiarize you with the typical steps that are taken when installing a solar water pumping system. Your particular installation may require the steps to be done in a different order. You should read the whole manual before making your first installation.



WARNING – This installation overview does not substitute the detailed instructions given in this manual. Read and follow the manual carefully to ensure reliable operation and long life of the product and to avoid danger to health and life.

Below you find a collection of mandatory and optional tools which are useful for installing the pump.

Table 1: Tool list

Mandatory tools	Recommended additional tools
Screw driver, PH2 (cover & shield clamps)	Isolation tester 1000 V (Megohmmeter)
Screw driver, flat, 0.6 x 3 mm (Sensor terminals)	Clamp meter for DC current
Wire stripper	Crimping tool for non-insulated sleeves
Wrench, 13 mm (Grounding bolt)	
Multimeter (min. 1000V DC)	
LORENTZ Assistant Android™ App	

2.1 Registration of components

Before you start the installation please register all components (e.g. Pump end, Motor, Pump Controller) on Sites in partnerNET (Support, Sites) or by using the LORENTZ Assistant App. This is mandatory and needs to be done to run the pump.

2.2 PV and Controller Installation

Please follow the manufacturers instructions for PV installation. Every PV installation must be equipped with a PV disconnect switch rated for DC. Suitable switches are available from LORENTZ.

Please refer to "8 Pump Installation" on page 49 for more information on the requirements the PV disconnect must meet.

Install the controller close to the PV array in a shaded location to minimize cable length on the input side.

For detailed information refer to "7.3 Mounting, Space and Ventilation Requirements" on page 27.

2.3 Electrical installation

1. Pump wiring: The motor must be connected to the terminals U, V, W, and PE. Observe rotation direction.

For detailed information refer to "8.2.2 Wiring the pump" on page 52.

2. Accessories wiring for PSk3-7 and PSk3-15: Connect a well probe to terminals 1 and 2 (required), remote control switches to terminals 3 and 4, water meter to terminals 5 and 6, analog sensors to terminals 7 and 8 or 9 and 10, water detection sensor for surface pump to terminals 14, 15 and 16, Sun Sensor module to terminals 17 and 18.

For detailed information refer to „7.4.1.5 Pump Accessory Wiring“ on page 40.

3. DC input wiring: Connect the positive terminal of the PV array to +, the negative terminal to -. The max. input voltage provided by the PV array must not exceed the specified max. input voltage of the product.

For detailed information refer to „8 Pump Installation“ on page 49 and "Table 2: Technical Data of the PSk3 Controller" on page 12.

4. AC input wiring: Connect the AC input phases to the L1/L2/L3 and PE terminals.



WARNING – Do not ground PV+ or PV-. Grounding either PV+ or PV- while using an AC power supply will result in significant damage and destroy the controller.

5. Grounding: A protective earth connection must be wired to PE Ⓧ.

For detailed information refer to "7.5 Grounding" on page 46.

2.4 Pump Installation

Submersible pumps: Lower the pump into the water source with caution, use a safety rope.

For detailed information refer to "8.2 Submersible Pumps" on page 51.

Surface pumps: Install the surface pump on an adequate foundation with sufficient pipe sizing to ensure efficient operation. Fill the pump with clean water prior to starting it.

Depending on your pump system, refer to "8.3 Surface Pumps" on page 63 for detailed information.

2.5 Feature configuration with LORENTZ Assistant

1. Installation settings: select your controller and pump unit type and make basic settings (this is mandatory for perfect operation and data monitoring).

2. Dashboard: check your pump's performance in the last hour, day, month or year

3. Operational settings: if required choose a time limit or a water limit (e.g. for a low-yielding borehole or hybrid operation with a smaller diesel generator)

4. Device info: check hardware and firmware versions

← PSk3 Demo Pump

DASHBOARD DATA **SETTINGS**

Installation Settings

Name
PSk3 Demo Pump

Controller
PSk3-15

Pump unit
PSk3-15 C-SJ17-11

Cable length [m]
25.0

Cable size
25 mm²

Estimated TDH [m]
Calculated

Clock Synchronization
2022-02-16 10:18:10

Sun Sensor

Serial number
12345678

Sun Sensor switch

Stop pump below [W/m²]
150

← PSk3 Demo Pump

DASHBOARD DATA **SETTINGS**

Data

Input power AC and Solar [kW]

1.4 13.7

Power AC ● Power solar

Flow measured
22.0
m³/h

Irradiation
892
W/m²

Pumped water
124.0
m³

Analog input 1
Pressure Sensor
5.5
4.61 bar

Analog input 2
Level Sensor
45.0
60.28 m

SHOW MORE

← PSk3 Demo Pump

DASHBOARD DATA **SETTINGS**

Operational Settings

Activate hybrid

Interval timer

Clock timer

Hybrid on low solar

Hybrid on below [W/m²]
400

Hybrid off above [W/m²]
600

Hybrid off delay [s]
120

Daily AC energy limit

AC max. power target

Max. speed limit

Control pump

← PSk3 Demo Pump: Version/F...

Control Board

Hardware version	1.1.A
Control firmware version	1.7.3
Power firmware version	1.9.1

IO Board

Hardware version	1.1.A
Firmware version	1.3.17

Firmware Update

FIRMWARE UPDATE

Factory Reset

FACTORY RESET

3 PSk3 and LORENTZ Assistant



INFORMATION – LORENTZ Assistant holds the latest versions of pump system firmware as well as new features. We highly recommend that you update LORENTZ Assistant regularly. LORENTZ Assistant is free for all users.

LORENTZ Assistant for Android™ is an important tool to correctly set up LORENTZ pump controllers via a Bluetooth® connection. Setting up the pump and mandatory accessories, e.g. Sun Sensor, is required for full performance and to not void the warranty.

To install LORENTZ Assistant search for "LORENTZ Assistant" in Google Play Store* or scan the following QR code which leads you directly to the app in Google Play Store.

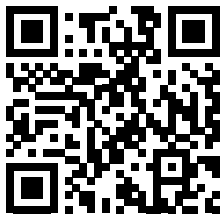

To find more information on how to use LORENTZ Assistant for LORENTZ products, search for "LORENTZ Assistant" in partnerNET.

For more information on LORENTZ Assistant, other LORENTZ tools and support visit LORENTZ partnerNET which contains a rich collection of helpful articles and videos.

* Google Play and the Google Play logo are trademarks of Google LLC.

4 Product Information

4.1 Product Description

LORENTZ PSk3 solar submersible and surface pump systems are designed to efficiently deliver the highest volumes of water at high efficiency.

PSk3-C-SJ submersible and PSk3-CS surface pump systems are typically used in irrigation projects and for a wide area of drinking water applications where they reliably meet the most demanding requirements, economically, environmentally friendly and without a grid connection or diesel generator. The system is composed of a pump, a pump controller and a PV generator array which is an aggregation of PV modules connected in series and in parallel, absorbs solar irradiation and converts it into electrical energy, providing power for the whole system.

The pump controller controls and adjusts the system operation and converts the DC produced by the PV generator into AC to drive the pump, and adjusts the output frequency in real-time according to the variation of sunlight intensity to realize the maximum power point tracking (MPPT). Based on the design philosophy that it is more efficient to store water rather than electricity, there is no energy storing device such as storage battery in the system.

There are applications where the need for water cannot be met with solar power and water storage alone. For these cases and if there are specific seasonal demands, constant pressure or constant flow requirements, an AC power source can be directly connected to the PSk3 controller which seamlessly blends both power sources and supports the PV power source to meet the customers' requirements. In cases where no PV power is available, the system can be powered only via an AC source.

4.2 Technical Data of the PSk3 Controller

Table 2: Technical Data of the PSk3 Controller

Model		
	PSk3-7	PSk3-15
Input (DC)		
Max. PV voltage	850 V	
Voltage range	400 ... 850 V	
Minimum MPPT voltage	575 V	
Max. current	14 A	27 A
Max. I_{sc} PV array	30 A	40 A
Max. inverter backfeed current into array	0 A	
Input (AC)		
Rated voltage	380 ... 480 V +/- 10%	
Frequency range	45 - 60 Hz	
Max. current	17.5 A	30 A
Max. current (inrush)	42 A	
Max. fuse ratings	20 A	35 A
Grid type	TN / TT *	
Output (AC)		
Rated voltage	380 V	
Voltage range	380 V / 400 V / 415 V / 440 V / 460 V / 480 V	
Rated frequency	50 Hz	
Frequency range	0 ... 60 Hz	
Rated current	13 A	24.5 A
Rated output power	8.3 kVA	16 kVA
Min. rated power factor	0,85	
Rated power of motor	5.5 kW	11 kW

*Can only be used with star/wye network. For further information please get in touch with your LORENTZ distributor.

General	
Protection	I
Ingress protection	IP 66
Overvoltage category	II (PV), III (AC)
Ambient temperature range	-25 ...60°C*
Cooling concept	forced cooling
Max. altitude rating	2000 m
Mechanic Dimensions (HxWxT)	428x280x180 mm
Weight	15 kg / 33.07 lbs

*Depending on the actual load situation, a power derating may apply at ambient temperatures above 50°C. This allows the pumping system to continue operation at reduced power instead of switching off completely.

4.3 Technical requirements for the pumps

LORENTZ PSk3 submersible and PSk3 CS-F/CS-G surface pumps can be used for drinking water supply, livestock watering and irrigation applications not containing solid or long fibred particles larger than sand grains, with a max. grain size of 2 mm. The max. permitted sand content for submersible pumps is 50 ppm, for surface pumps 20 ppm. A higher sand content will reduce the pump life considerably due to wear. The max. salt content is 300-500 ppm at max. 30 °C / 86 °F. Defects due to pumping other liquids are not covered by the warranty. The maximum fluid temperature for PSk3 submersible pumps is +30 °C (86 °F), for PSk3 CS-F surface pumps its +70 °C (158 °F) and for PSk3 CS-G surface pumps +90 °C (194 °F).

PSk3 surface pumps should be sited in a well-ventilated and frost-free position. The distance between the pump unit and other objects should be at least 150 mm / 6" to ensure proper air circulation. If installed outside, the pump must be protected

from rain and direct sunlight. This will increase the durability of the pump. It should not be stored or operated within 1 km / 0.6 miles of coastal regions or in saline air (more than 2 µg/m³).

Additional information about pumps and motors can be found in the LORENTZ COMPASS sizing software.

4.4 Naming convention

A PSk3 pump system name consists of two components. The first component refers to the pump systems controller while the second part refers to the pump model. A detailed overview about the pump model naming can be found below.

Pump model definition for C-SJ8-44 to C-SJ75-4 submersible pumps

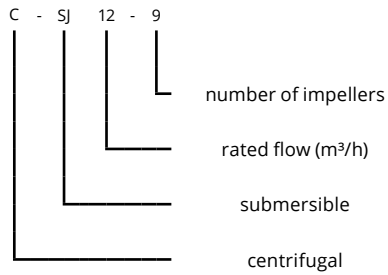

for C-SJ150-2-2 pumps

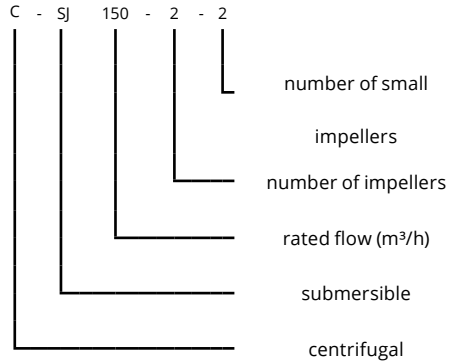

Pump model definition for CS-F12 to CS-F20 surface pumps

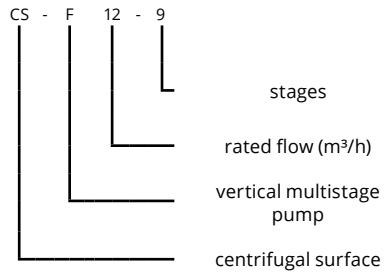

for CS-F32 to CS-F85 pumps

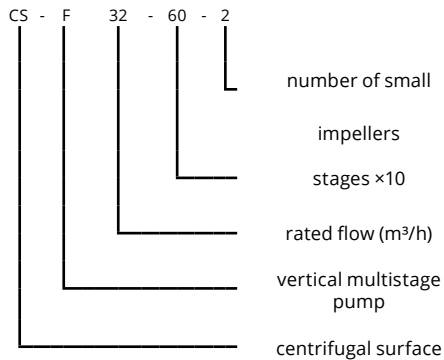

for CS-G pumps

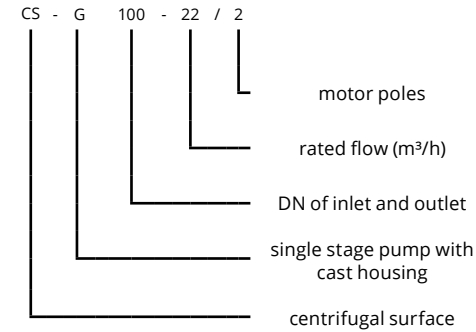

4.5 Storage of pump system components

Prolonged intermediate storage in an environment of high humidity and fluctuating temperatures must be avoided. Moisture condensation may damage metal parts. Non-compliance can void the warranty. It is recommended to store the parts in a closed and dry room. The pump system must not be stored or operated where the average day humidity is above 80%. The motor, the pump end and controller can be stored (not used) in the range of -20°C to +65°C (-4°F to +149°F). The components should not be exposed to direct sunlight.

4.6 Scope of delivery

Scope of delivery

#	Item	Quantity
1	PSk3 controller	1 unit
2	Sun Sensor module 1.5 Wp	1 unit
3	Cable gland reducer	2 units
4	Manual	1 unit

Check upon receipt that the packaging is undamaged and complete. If any abnormality is found, contact your supplier.

LORENTZ pumps are supplied from the factory in proper packing in which they should remain until they are to be installed at the site. Handle the pump with care and avoid unnecessary impacts and shocks.

5 Safety Instructions

Safe operation of this product depends on its correct transportation, installation, operation and maintenance. Failure to follow these instructions can be dangerous to life or health and/or void the warranty.

READ AND FOLLOW ALL INSTRUCTIONS!

Explanation of warning symbols



WARNING – Disregard can lead to injury, death or damage the system



CAUTION – Recommended to avoid damage, premature ageing of the pump or similar negative consequences.



Refer to the operating instructions.



WARNING – risk of electric shock, energy storage timed discharge. Refer to time written on symbol.

When installing and using this electrical equipment, basic safety precautions should always be followed, including the following:



WARNING – To reduce the risk of injury, do not permit children to use this product unless they are closely supervised at all times.



WARNING – The appliance is not to be used by persons (including children) with reduced physical, sensory or mental capabilities, or lack of experience and knowledge, unless they are instructed and closely supervised.

WARNING – To reduce the risk of electric shock, replace damaged cords immediately.

WARNING – It must be assured that all grounding connections are properly made and that the resistances meet local codes or requirements.

The manual contains basic instructions which must be observed during installation, operation and maintenance. Before installation and start-up, the manual should be carefully read by the person in charge of the installation. The manual should also be read by all other technical personnel/operators and should be available at the installation site at all times.

▪ **Personnel qualifications and training** – All personnel for the operation, maintenance, inspection and installation must be fully qualified to perform that type of job. Responsibility, competence and the supervision of such personnel must be strictly regulated by the operator. Should the available personnel be lacking the necessary qualification, they must be trained and instructed accordingly. If necessary, the operator may request the manufacturer/ supplier to provide such training. Furthermore, the operator/user must make sure that the personnel fully understand the contents of the manual.

- **Dangers of ignoring the safety symbols** – Ignoring the safety directions and symbols may pose a danger to humans as well as to the environment and the equipment itself. Non-observance may void the warranty. Non-observance of safety directions and symbols may for example entail the following: Failure of important functions of the equipment/plant; failure of prescribed methods for maintenance and repair; danger to persons through electrical, mechanical and chemical effects; danger to the environment because of leakage of hazardous material; danger of damage to equipment and buildings.
- **Safety-oriented operation** – The safety directions contained in the manual, existing national regulations for the prevention of accidents as well as internal guidelines and safety-regulations for the operator and user must be observed at all times.
- **General safety directions for the operator or user** – If hot or cold equipment parts pose a danger then they must be protected by the operator/user against contact with people. Protective covers for moving parts (e.g. couplings) must not be removed when the equipment is running. Leaks (e.g. at the shaft seal) of hazardous pumping media (e.g. explosive, toxic, hot liquids) must be disposed of in such a way that any danger to personnel and the environment is removed. All government and local regulations must be observed at all times. Any danger to persons from electrical energy must be eliminated by using good installation practices and working to local regulations (e.g. VDE in Germany).

- **Safety directions for maintenance, inspection and assembly work** – It is the user's responsibility to make sure that all maintenance, inspection and assembly work is performed exclusively by authorized and qualified experts sufficiently informed through careful study of the operating instructions. The accident prevention regulations must be observed. All work on the equipment must be done when it is not operational and ideally electrically isolated. Ensure all power sources and accessories (e.g. float switch) are disconnected when working on the system. Follow all appropriate electrical codes. There are no user-serviceable parts inside the motor or the controller. The sequence for shutting the equipment down is described in the manual and must be strictly observed. Pumps or pump units handling hazardous liquids must be decontaminated. Immediately upon completion of the work, all safety and protective equipment must be restored and activated. Before restarting the equipment, all points contained in chapter "8.3.5 Initial Start-up" on page 69 must be observed.

- **Unauthorized changes and manufacturing of spare parts** – Any conversion of or changes to the equipment may only be undertaken after consulting the manufacturer. Original spare parts and accessories authorized by the manufacturer guarantee operational safety. Using non-authorized parts may void any liability on part of the manufacturer. There are no user-serviceable parts inside the motor or the controller.
- **Unauthorized operation** – The operational safety of the equipment delivered is only guaranteed if the equipment is used in accordance with the directions contained in this manual. Limits stated in the data sheets may not be exceeded under any circumstances.

RETAIN THESE INSTRUCTIONS FOR FUTURE USE!

6 Pump System Sizing & Layout Diagrams

6.1 Pump System Sizing

To professionally size and install a water pumping system, various variables need to be taken into consideration depending on the pump type and application:

Static head - Vertical height from the dynamic water level to the highest point of water delivery.

Suction head (only applicable to non-submersible pumps) - Vertical height from the water level to the pump inlet where the water level is below the pump inlet.

Pressure losses - Loss of water pressure due to pipe length and friction caused by pipe material and additional pipeline elements like elbows, valves.

For solar water pumping additionally local **irradiation** levels are necessary to calculate the available power during each day and the effect on water output.

To easily manage and consider the different variables, LORENTZ strongly advises to size pump systems with LORENTZ COMPASS, the solar pump planning software.

COMPASS is the LORENTZ tool for designing, planning and specifying solar pump systems. It is available for download to all LORENTZ partners on partnerNET.

COMPASS is a PC-based tool to simply specify solar pumping systems in real time. It is based on NASA weather data and uses precise algorithms for even the most complex calculations.

By selecting the location from a list of more than 250,000 cities, entering the total dynamic head (TDH) and the necessary amount of water per day the software will automatically show suitable pump systems and the necessary size of the PV generator.

For more complex situations COMPASS offers features from suction head calculation to pipe type specific pressure loss calculation.

NOTE – Always ensure the values used for sizing with COMPASS match the conditions on site. Incorrect parameters can lead to a wrong sizing report.

Figure 1: COMPASS sizing

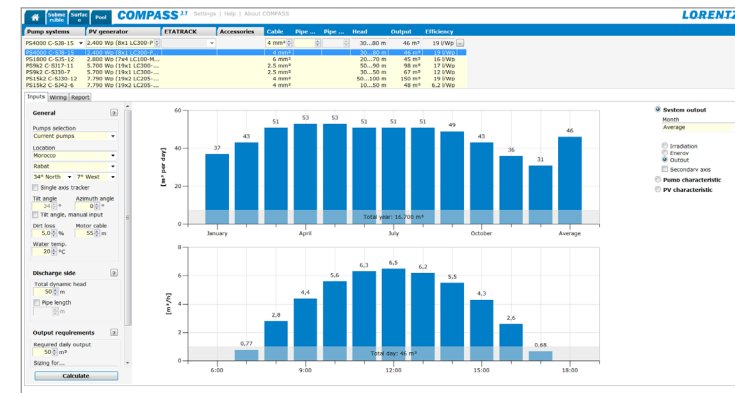

6.2 System Layout: Submersible Pumps

CAUTION - This graphic is an example pump system layout diagram and for ease of understanding only. For system installation and wiring read and the detailed instructions given in this manual.

Figure 2: Submersible pump layout

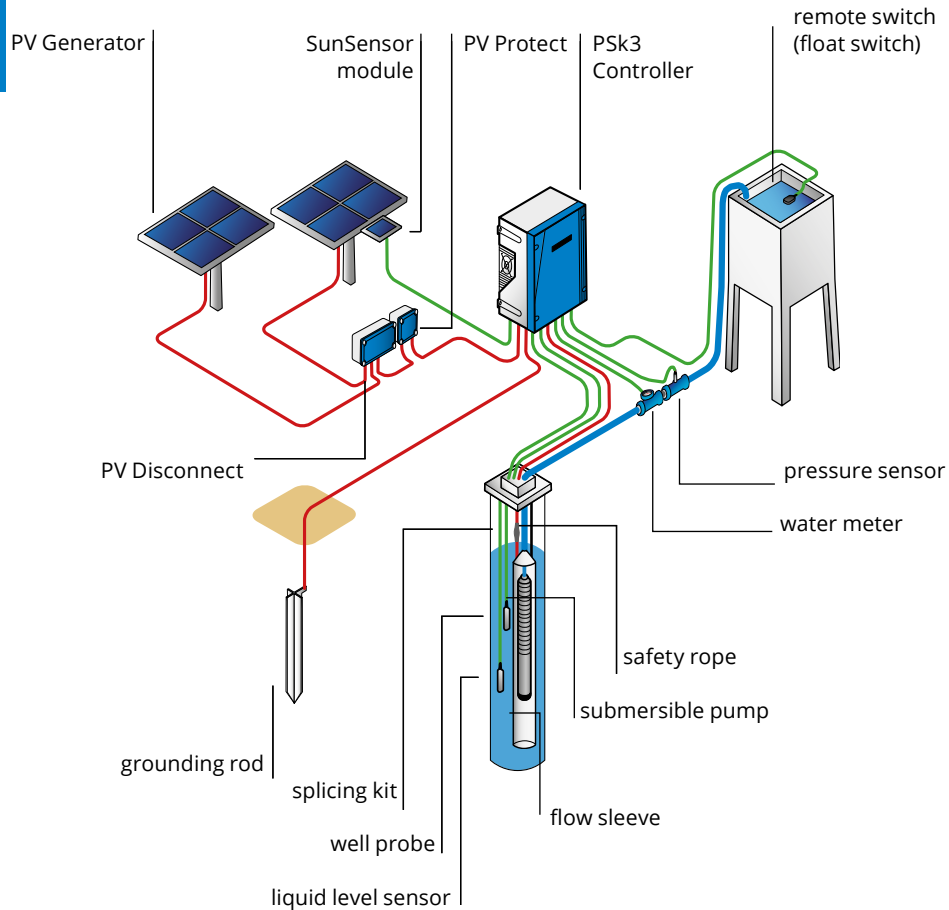

6.3 System Layout: Surface Pumps

CAUTION - This graphic is an example pump system layout diagram and for ease of understanding only. For system installation and wiring read and follow the detailed instructions given in this manual.

Figure 3: Surface pump layout

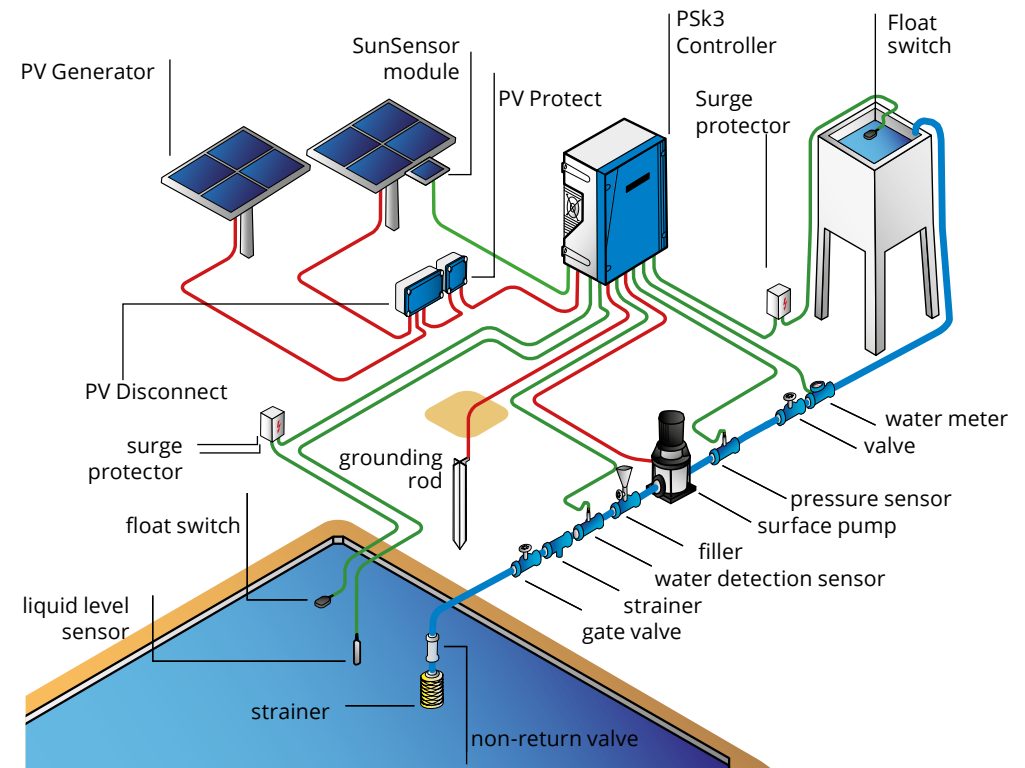

6.4 Solar-diesel system sizing considerations

The PSk3 is able to switch between solar and diesel as well as blend both power sources, e.g. to obtain a desired flow rate or pressure irrespective of sunshine.

It can operate on diesel generators with a constant power rating higher, equal or smaller than the power rating of the pump motor.

The constant power rating of the diesel generator should be selected considering the desired flow or pressure.

LORENTZ SmartSolution supports the following diesel generator specifications:

- 380/ 400/ 415/ 440/ 460 /480 V
- 50/ 60 Hz
- Remote start function (if use of SmartStart is desired)

Grid power SmartSolution

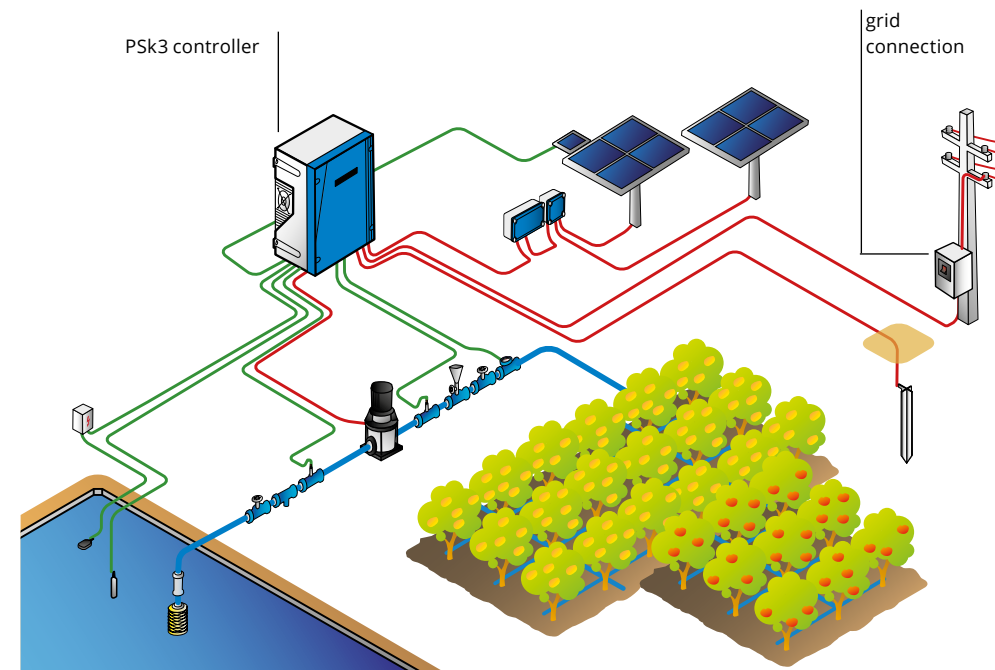

Generator SmartSolution

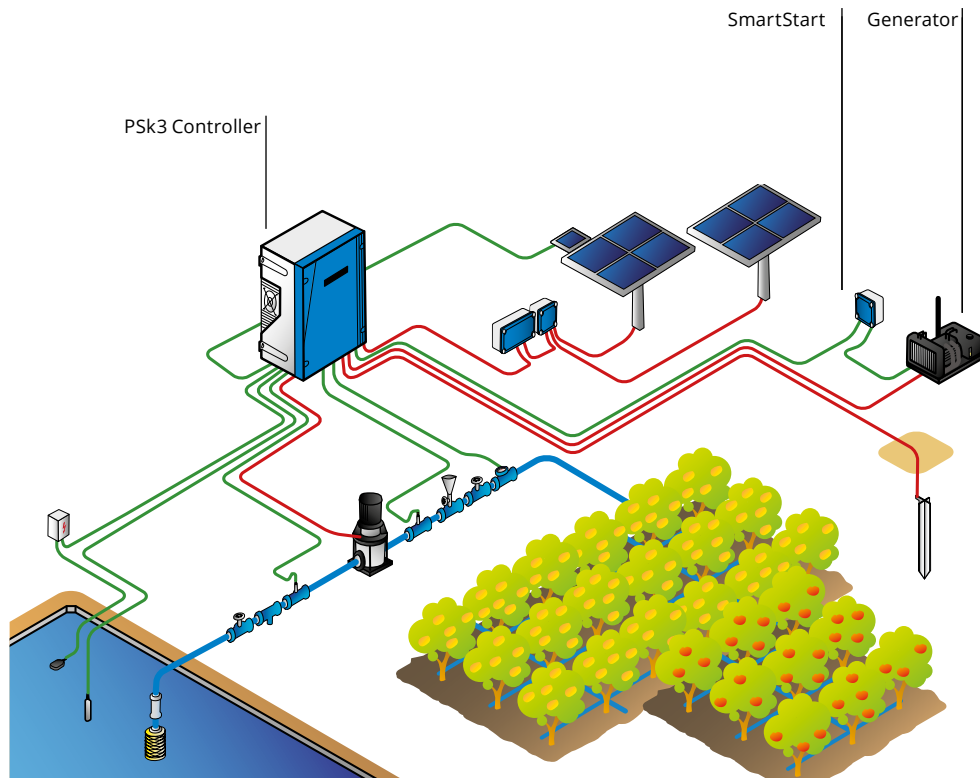

7 Controller Installation



WARNING – All electrical connections must be performed by qualified experts only.

WARNING – Do not dismantle the controller while still connected to the power supply! Before any installation, maintenance or inspection activities wait at least five minutes after the power supply has been disconnected from the controller!



CAUTION – To avoid multiple starts of the pump in twilight conditions, the Sun Sensor module must be connected and configured for all PSk3 pump systems. Operating without a Sun Sensor module can lead to increased wear or damage to the pump. Such damage is excluded from the warranty.

CAUTION – Never let the pump run dry. Dry running will damage the pump and void the warranty. LORENTZ requires a dry run protection for every pump system.

7.1 Controller Elements

- **Power on/off switch** – The power switch is used to start or stop the system and as a reset switch. It does not work as power disconnect switch.
- **Indicator Lights** – The six LED lights on the front indicate different operational situations. For a detailed explanation refer to chapter "10 Operating the Pump" on page 87

7.2 Controller Placement

The PSk3 controller is rated for outdoor use with an ingress protection rating of IP66. This means that inside electronics are protected against dust and strong water splashes when properly installed. Keep the controller cover sealed all times as the inside electronics are sensitive to water, moisture, dust or animals.

Electronic devices are most reliable when they are protected from heat. Mount the controller where it is shaded from the midday sun. An ideal location is in permanent shade. If no shade is available, cut a piece of sheet metal and bolt it behind the top of the controller. Bend it over the controller to provide shade. Make sure that the fan of the PSk3 is not covered and forced cooling it possible.

This is especially important in extremely hot locations. Extreme heat may trigger a thermal function in the controller causing it to reduce the power consumption or turn it off.

Place the controller close to the pump to keep the motor cable short.

If the installation is exposed to lightning, we recommend using a surge protector and put it inside the controller.

Figure 4: PSk3 controller dimensions for installation

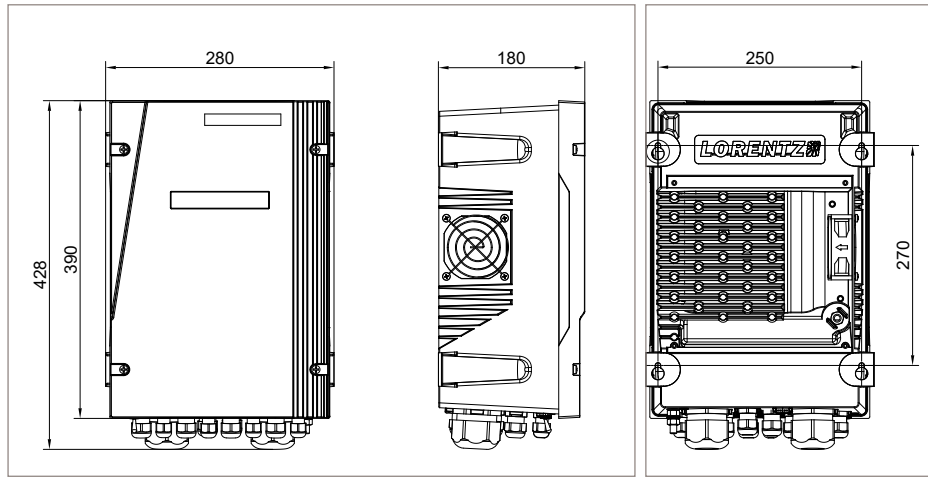

Table 3: PSk3 controller dimensions for installation

Dimension in mm [in]							Weight in kg [lbs]
W1	W2	W3	H1	H2	H3	D1	
280	250	280	390	270	428	180	15
[11.02]	[9.84]	[11.02]	[15.35]	[10.63]	[16.85]	[7.09]	[33.07]

7.3 Mounting, Space and Ventilation Requirements

The PSk3 controller must be mounted on a solid wall or a rigid structure.

The installation plane must be concrete, metal, stone or any other material with similar properties that can absorb a tensile force of 200 N per screw after the controller has been installed. The screw size should be M5 or M6 and enable even fastening of the controller. If the material does not allow proper screw fastening, dowels can be used to support the structure and enable it to absorb a tensile force of 200 N per screw. After installation no additional load should be put on the controller, e.g. storing material on top of the controller, which could increase the load on the fixation plane.

First, mark all drill holes. Refer to „Table 3: PSk3 controller dimensions for installation“ on page 26. Fit all screws, leave about 10 mm / 0.4“ space between the screw’s head and the wall. Hang the controller on the wall. Finally, tighten all screws.

For grounding of the front cover the cover screws must be tightened to a minimum torque of 2 Nm.

PSk3 controllers can be mounted side by side. Make sure to keep the minimum spacing shown in „Figure 5: Minimum spacing for wall mounting“ on page 27.

Figure 5: Minimum spacing for wall mounting

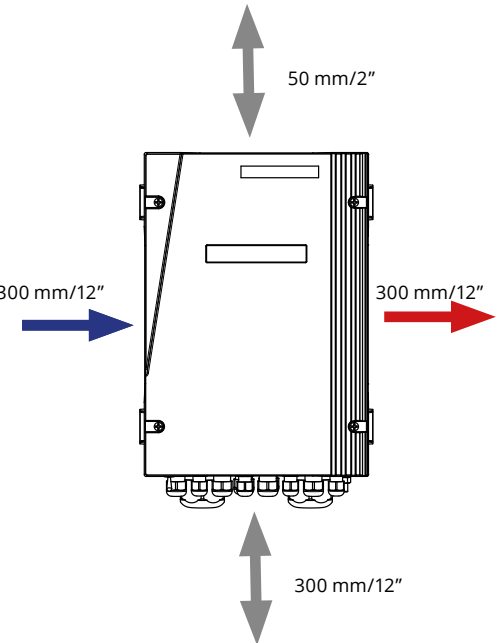

7.4 Wiring the controller



WARNING – All electrical connections must be performed by qualified experts only! Unqualified handling might lead to shock, burns, or death.

WARNING – Beware of high voltage. Never work on a system connected to power or within two minutes after disconnection to avoid electric shock hazard.



WARNING – Do not dismantle the controller while still connected to the power supply! Before any installation, maintenance or inspection activities wait at least five minutes after the power supply has been disconnected from the controller!

Before starting to work on the electrical system make sure that all components are disconnected from the power source. Do not work on any components when power is connected or within five minutes after disconnection. The controller needs time to discharge.

Switch the system on only when all work is completed.



CAUTION – The controller should only be connected to power after correct wiring or the controller might get damaged.



CAUTION – Do not install disconnect switches in the power wires between the motor and pump controller. Connecting the motor wires to a switched-on controller may cause irreparable damage. Such damage is excluded from the warranty.

CAUTION – Solar-direct systems only – Do not connect any electrical load to the PV generator other than the LORENTZ pump controller. Connection of a battery charger, active solar tracker controller, electric fence charger, or other load simultaneously with LORENTZ PSk3 systems may interfere with the controller and prevent proper operation.

CAUTION – Measure the voltage before connecting power to the controller. Voltage (open circuit) must not exceed the max. DC input.



NOTE – PSk3 can be supplied by solar and / or an AC source. This can lead to an interaction of both sources, especially if the system is not properly installed. Special care must be taken when installing the PSk3 controller in hybrid configuration. Carefully read the following chapters.

7.4.1 Controller wiring for solar only

7.4.1.1 Terminal description

Open the housing by loosening the four screws on the front cover. After removing the cover the terminal can be accessed easily.

For “Solar-IN” and “Motor-OUT” open the clamp, insert the wires and lock the clamps in place. Use caution and keep hold of the clamp handles as the terminals contain strong springs. Refer to „Figure 8: Spring connector for "Solar-IN" and "Motor-OUT"“ on page 31. The length of wire stripping for these terminals is 12-13 mm (0.5 in).

For terminals 1 to 18 open the terminal by pushing back the clamp handle with a screwdriver, insert the wire, then release the handle to lock the wire in place. Refer to "Figure 9: Spring connector for "Sensor terminals 1-18 and fan terminal"“ on page 31. The length of wire stripping for these terminals is 5 - 6 mm (0.2 in).

Figure 6: View of open PSk3 controller

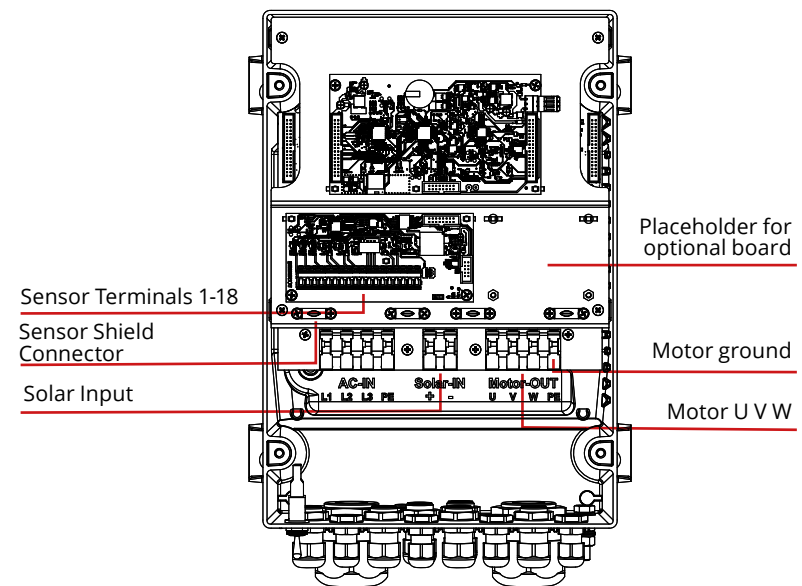
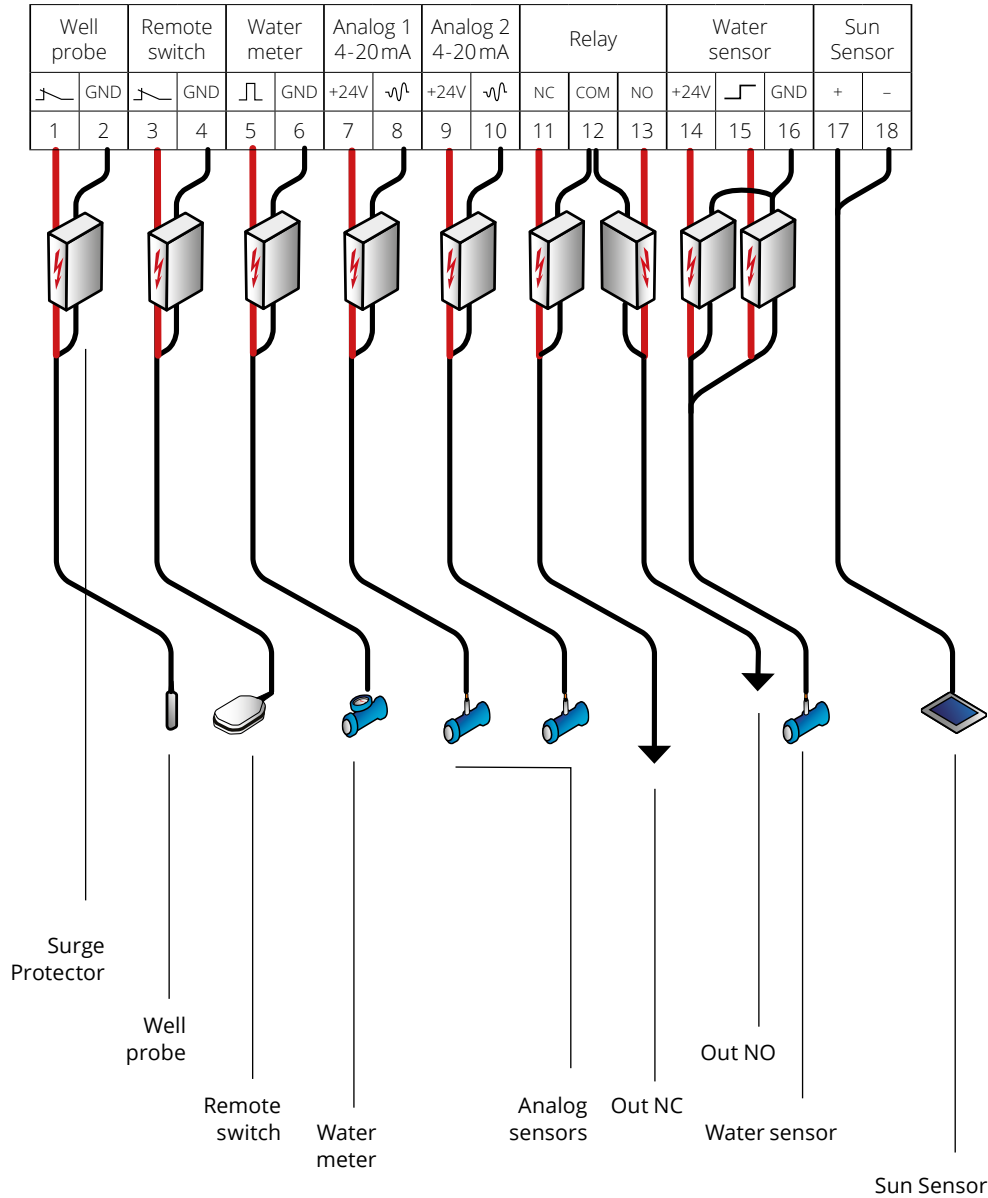

Figure 7: Sensor terminal wiring example



Terminal description PSk3

Figure 8: Spring connector for "Solar-IN" and "Motor-OUT"

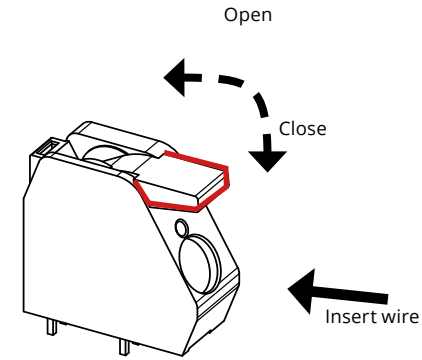

Figure 9: Spring connector for "Sensor terminals 1-18 and fan terminal"

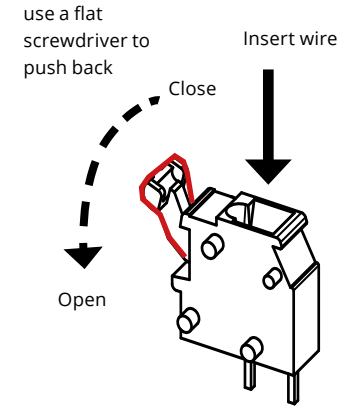
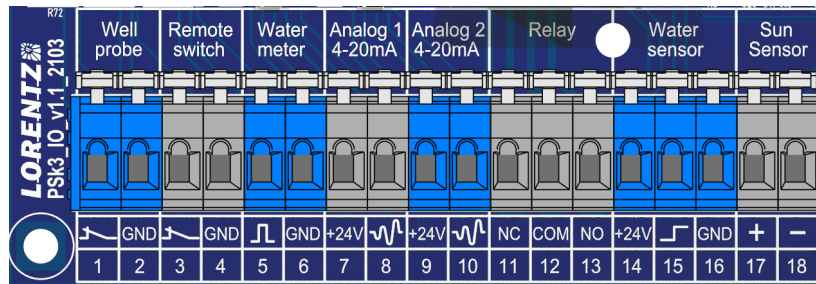

Table 4: Clamping range of connectors

Terminal	AWG size	Metric size
Motor	16 - 6 AWG	1.5 - 16 mm ²
PV	16 - 6 AWG	1.5 - 16 mm ²
Sensor	28 - 12 AWG	0.08 - 2.5 mm ²

Figure 10: PSk3 sensor terminals



COM = common; GND = ground; NC = normally closed; NO = normally open; PE = protective earthing

Table 5: Sensor terminal explanation

Socket	Terminal	Connection	Function
Well probe	1	connect to NC	Connect a well probe or float switch to terminal 1+2 to protect the pump system from running dry. Every pump system must be equipped with a dry run protection. Connect a jumper between 1+2 if not used.
	2	connect to GND	
Remote switch	3	connect to NC	Connect a tank switch, pressure switch or any other suitable remote switch to terminal 3+4. Connect a jumper between 3+4 if not used.
	4	connect to GND	
Water meter	5	connect to Signal	Connect a device that provides a potential-free impulse signal, e.g. a reed contact. Water amount per impulse must be configured with LORENTZ Assistant. Allowed pulse rate ≤ 200 Hz.
	6	connect to GND	
Analog input 1 (4-20mA)	7	connect positive (+)	4-20 mA signal sensor supply voltage +24V load impedance 100Ω; observe correct polarity
	8	connect negative (-)	
Analog input 2 (4-20mA)	9	connect positive (+)	4-20 mA signal sensor supply voltage +24V load impedance 100Ω; observe correct polarity
	10	connect negative (-)	

Relay	11	connect to NC	Potential-free signal output to control third party devices; must be configured with LORENTZ Assistant; either NC or NO operation can be used
	12	connect to COM	
	13	connect to NO	
Water detection sensor	14	optional: connect positive (+)	Connect water detection sensor for surface pumps – for submersible pumps a jumper wire is needed between 15+16. If necessary, use 24 V DC supply from terminal 14. The connected sensor must not draw a higher current than 20 mA, if the optional power terminal is used.
	15	connect to Signal	
	16	connect to GND	
SunSensor module	17	connect positive (+)	Connect the SunSensor to terminal 17+18 and observe polarity. The SunSensor is included with the PSk3 controller and needed to protect the pump.
	18	connect negative (-)	
AC In	L1	connect to L1 phase of the AC grid	Power supply from an AC source, e.g. a generator or a grid connection
	L2	connect to L2 phase of the AC grid	
	L3	connect to L3 phase of the AC grid	
	PE	connect to protective ground wire (PE)	
Solar IN	+	connect positive wire of PV generator	Power supply from the PV generator
	-	connect negative wire of PV generator	
Motor OUT	U	connect to phase 1 of motor	Observe correct rotational direction of pump
	V	connect to phase 2 of motor	
	W	connect to phase 3 of motor	
	PE	connect to protective motor ground wire (PE)	

7.4.1.2 Cable entries

There are cable glands of different diameters in the bottom of the controller.

Power cables and accessories which use the cable glands must be tightened properly in the glands for strain relief and sealing.

If a power cable cannot be tightened because its diameter is too small for the cable gland, a suitable cable gland reducer has to be used to fit the hole of the cable gland to the cable diameter. Two sizes of cable gland reducers are included with the PSk3 controller.

Figure 11: PSk3 controller front view

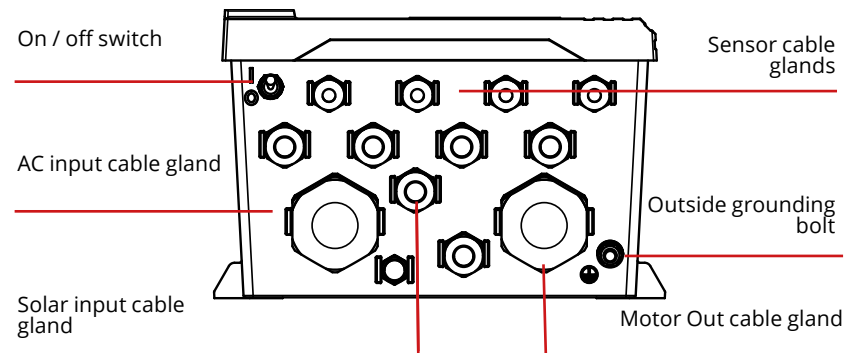

7.4.1.3 PV Array Wiring



WARNING – When the photovoltaic array is exposed to light, it supplies a DC voltage to the PSk3 Controller.

WARNING – Do not ground solar! Grounding solar when also using AC power supply destroys the controller! Failure to do so will result in significant damage to the controller.

It is the installers' duty to correctly size and install the solar array, which includes all required components like solar generator, cables, fuses, combiner, disconnection devices and surge protectors. Installation shall be made depending on local installation requirements and conditions.

Only IEC 61730 compliant solar modules shall be used with a system voltage rating of at least 1000 V DC.

The pump system must be equipped with a proper sized DC disconnect switch for safe installation and maintenance of the controller. The switch must be installed between the solar generator and the controller. It must meet the following requirements:

- minimum 850V DC
- continuous current rating according to maximum current of pump controller or higher
- capable of carrying and switching the max. short circuit current of the solar array
- the switch must be rated for DC current, NOT AC

A PV disconnect switch that matches all these requirements can be purchased from LORENTZ.



NOTE – The use of a properly sized disconnect switch is an important safety measure and mandatory for a professional installation of a solar pump system.

The diagram „Figure 12: Example configuration of different components“ on page 37 provides an example configuration. The exact requirements will depend on the module configuration as defined in COMPASS for the system being installed.

Electrical conduit

Electrical conduit is recommended. We recommend the use of an electrical conduit (pipe) to protect outdoor wiring from the weather, from human activities and from damage caused by animals. If you do not use a conduit, use a strong, high-quality outdoor cable. Where cables enter the junction box, install sealed strain relief cable glands.

7.4.1.4 Motor Wiring

7.4.1.4.1. Connecting the motor cable

The surface pump motor has a wiring box that contains the connection terminals for the three motor phases.

The pump motor provides bolt terminals to connect the motor cable. For a professional and reliable connection it is required to use cable lugs for connecting the motor cable to the bolt terminals.

The motor phases are labeled with "U", "V", "W".



CAUTION – The wiring order will have impact on the motor rotation direction. The correct rotation direction is marked with an arrow sticker on the pump and motor.

CAUTION – Observe the rotation direction of the pump when the system installation is finished and the pump was been successfully primed with water.

In case the rotation direction is incorrect exchange any two of the three motor phases to reverse the rotation direction.

7.4.1.4.2. Resistance measurement

We recommend checking the winding and insulation resistance before connecting the pump to the controller. For a surface pump these measurements should be done BEFORE taking the pump into operation.



WARNING – Before starting any work on the pump system, make sure that the electricity supply has been switched off and that it cannot be accidentally switched on!

To measure the winding and insulation resistance disconnect all motor leads from the controller. A good quality multimeter is necessary to measure the phase-to-phase resistance with an accuracy to the first decimal place. ("0.1 Ohms"). It is also advisable to consider the resistance of the multimeter leads when measuring very low values:

- Hold the tips of the multimeter together and note the value.



NOTE – Always subtract this value from your motor resistance measurements!

Winding resistance

- (1) Set the multimeter to "resistance measurement" and select the lowest measuring range.
- (2) All PSk3 motors are 3-phase motors. Measure the resistance of phase-to-phase: 1-2, 2-3, 3-1. Make sure there is good contact between the probes and the cable.
- (3) The deviation between the phases should be within 10 %. If the deviation is too high, the reason is likely a damaged submersible cable or a faulty cable splice.
- (4) The absolute value is made up of the resistance of the motor winding and the submersible cable. The resistance of the submersible cable depends on its length and size. For copper cable the values of the table "Table 6: Motor cable resistance" on page 38 and "Table 7: Winding resistances for surface pump motors" on page 39 can be used as a rough approximation.

Figure 12: Example configuration of different components

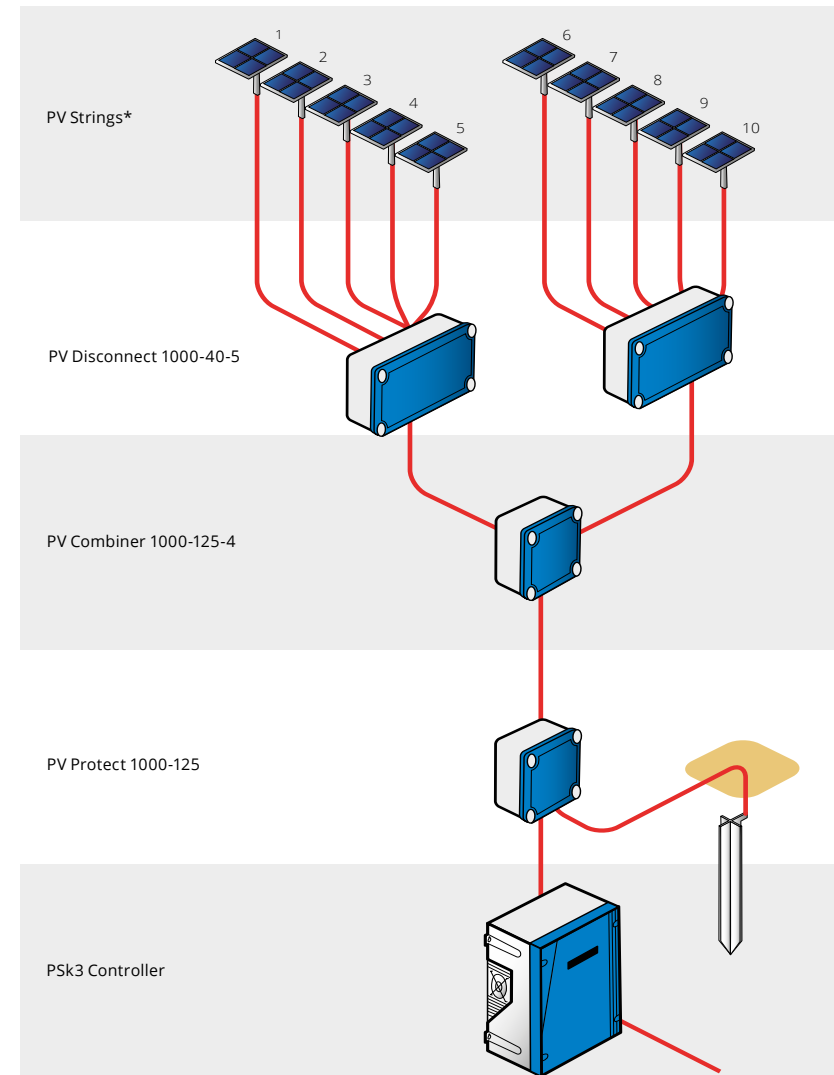

*It is the installer's duty to safely install the solar array according to local standards.

Table 6: Motor cable resistance

Cable	Resistance [Ω / 100 m]
2.5 mm ² / AWG 13	0.82
4 mm ² / AWG 11	0.40
6 mm ² / AWG 9	0.25
10 mm ² / AWG 7	0.17
16 mm ² / AWG 5	0.10

Example:

- Motor:
AC DRIVE CS-F 7.5 kW → 1.4 Ω
- Motor cable:
150 m and 6 mm² → 0.25 Ω / 100 m

Calculation of expected phase-to-phase resistance:

$$\begin{aligned}
 &= 1.4 \Omega + 2 \times 150 \text{ m} \times 0.25 \Omega / 100 \text{ m} \\
 &= 1.4 \Omega + 2 \times 0.375 \Omega \\
 &= 1.4 \Omega + 0.75 \Omega \\
 &= 2.15 \Omega \\
 &= \sim \mathbf{2.2 \Omega}
 \end{aligned}$$

The real measured values can be different, depending on the measurement equipment and materials that are used. This is just an approximation.

Insulation resistance

Use a megohmmeter at 500–1,000 V.

Measure each phase to ground. Connect one test prod to the phase, hold the other test prod to the pipe work, or if plastic pipes are used to the ground wire.

If the insulation resistance is below 0.5 MΩ, the motor cable must be checked for damage.

Wire sizes

For motor cables, the minimum wire size depends on the system size and sizing. Compare your wire sizes to the LORENTZ COMPASS sizing reports. Cables should be shielded to meet EMC requirement.

For outdoor use, cables meeting the requirements of IEC 60245-66 are recommended. For indoor use, the recommended cable type is defined in IEC 60245-57. The installer must always consider the local situation, codes of practice and regulations and use a cable that meets these requirements.

Table 7: Winding resistances for surface pump motors

Surface pump CS-F motors	PSk3 system	Phase-to-phase resistance [Ω]
AC DRIVE CS-F 5.5 kW	PSk3-7	1.4
AC DRIVE CS-F 7.5 kW	PSk3-15	1.4
AC DRIVE CS-F 11 kW	PSk3-15	0.8
Surface Pump CS-G Motors	PSk3 system	Phase-to-phase resistance [Ω]
AC DRIVE CS-G 5.5 kW	PSk3-7	1.7
AC DRIVE CS-G 7.5 kW	PSk3-9	1.3
AC DRIVE CS-G 11 kW	PSk3-15	0.8
AC DRIVE CS-G 11 kW/4p	PSk3-15	0.8

Motor filter

Due to the high voltages, high power and variable frequency inverter technology used in solar pumping systems, voltage spikes can occur which can have an ageing effect on motor winding insulation. To mitigate this effect, it is common to use a filter between the PSk3 controller and the motor.

The level of accelerated ageing depends mainly on the cable length and DC input voltage. Using a filter reduces stress on the motor. The filter should be connected directly on controller output motor connections (U,V,W).

LORENTZ recommends using motor filters.

Further information concerning motor-filters can be found in the knowledge base in PartnerNET.



NOTE – Cable sizing in LORENTZ COMPASS sizing reports is based on standard cables valid up to an ambient temperature of 30°C. The installer must check if the installation requires a higher cable diameter due to ambient conditions.

Electrical conduit

Electrical conduit is recommended. We recommend the use of an electrical conduit (pipe) to protect outdoor wiring from the weather, from human activities and from damage caused by animals. If you do not use a conduit, use a strong, high-quality outdoor cable.

7.4.1.5 Pump Accessory Wiring



CAUTION – Never let the pump run dry. Dry running will damage the pump and void the warranty. LORENTZ requires a dry run protection for every pump system.

Terminals 1 and 2 (Well Probe)

To protect the pump from being damaged by dry running connect a suitable source low protection switch to terminal 1 and 2. If dry run protection is not needed, add a jumper wire between these two terminals.

Terminals 3 and 4 (Remote Switch)

Connect any kind of external switch for remote control of the controller. To run the pump the switch must be closed (NC). If no switch is used the terminals No. 3 and 4 have to be connected with a jumper cable (factory setting).

Terminals 5 and 6 (Water Meter)

Install a water meter in the pipeline and connect it to terminal 5 and 6. The output of the water meter must be an impulse signal. The time between two impulses must not exceed 5 minutes. The controller can handle impulses with a frequency up to 1 Hz. Select a water meter appropriate for the expected flow. The flow can be viewed with the LORENTZ Assistant software.

Terminal 7 and 8 (Analog Input 1) and 9 and 10 (Analog Input 2)

Any suitable sensor for 24 V DC supply voltage, current (signal) range of 4 – 20 mA and load impedance of 100 Ω can be connected, e.g. LORENTZ pressure sensor, LORENTZ liquid level sensor. The sensor must then be configured in LORENTZ Assistant.

If shielded cable is used (recommended), connect the shield to the provided clamping terminals.

Terminals 11, 12, 13 (Relay)

This is a volt-free signal output that can be configured in LORENTZ Assistant to control third party devices. The relay offers NC ("Normally Closed") and NO ("Normally Open").

If the relay is not activated NC and COM are connected.

If the relay is activated NO and COM are connected.



WARNING – Do not connect any voltage higher than 250 V AC or 30 V DC to any of the terminals. The max. allowed current running over the relay is 2 A.

Terminals 14, 15, 16 (Water Sensor)

Connect a water sensor to detect the presence of water. This is usually installed on the suction side of surface pumps for dry run protection. If no water sensor is connected, a jumper wire must be installed between terminals 15 and 16 (factory setting).

The sensor can be a resistive sensor type, which pulls down the signal in case of water detection.

It is also possible to connect an active water sensor, which needs a power supply. The supply can be taken from terminal 14 (24V) and referenced to Pin 16 (GND). The maximum allowed current for the sensor supply is 20 mA.

For the installation of a LORENTZ water detection sensor (resistive type) remove the jumper cable between terminals 15 and 16. Connect the sensor to these terminal clamps (the polarity is irrelevant). Other water detection sensors may require a different connection.

Terminal 17 and 18

Connect the LORENTZ Sun Sensor module. This PV module is used to measure the solar irradiation and allows you to set irradiation dependent START / STOP values for the pump. These settings can only be done via LORENTZ LORENTZ Assistant.



WARNING – It is not recommended to connect / change a sensor, while the motor is running. Do not connect sources with a voltage above 24 VDC.

7.4.1.6 Solar Panel for Sun Sensor



WARNING – To avoid multiple starts of the pump in twilight conditions, the Sun Sensor must be installed and configured according to COMPASS data. Multiple starts due to an incorrectly configured SunSensor can lead to increased mechanical wear and damage the pump. Such damage is excluded from the warranty.

The PSk3 controller is supplied with a special small 1.5 Wp PV module (pre-wired for crimping). This PV module is used to measure the solar irradiation and allows you to set irradiation dependent START / STOP values for the pump. These settings can only be done via LORENTZ Assistant. (Please check LORENTZ partnerNET and the LORENTZ Assistant manual).



WARNING – Do NOT use any other PV module than the one supplied or the PSk3 controller may be damaged.

Mount the PV module with the same alignment as the solar array that powers the pump system. For example, if the solar array is tilted at an angle of 20°, the PV panel for the Sun Sensor should be tiled exactly the same. You can ensure this by mounting the PV module on the frame of the PV module array. Take care of correct polarity.



WARNING – Voltage reversal of the Sun Switch panel will lead to damage of the controller.

WARNING – You must not exceed the maximum voltage or current ratings for any part of the system.

Please see "9 Pump Accessories Installation" on page 71 for more information on the available accessories and refer to the product manuals on partnerNET.

7.4.2 Controller wiring for hybrid operation



WARNING – Do not dismantle the controller while still connected to the power supply! Before any installation, maintenance or inspection activities wait at least FIVE MINUTES after the power supply has been disconnected from the controller!



NOTE – PSk3 can be supplied by solar and / or an AC source. This can lead to an interaction of both sources, especially if the system is not properly installed. Special care must be taken when installing the PSk3 controller in hybrid configuration. Carefully read the following chapters.



CAUTION – This product can cause current with a DC component. Where a residual current-operated protective (RCD) or monitoring (RCM) device is used for protection in case of direct or indirect contact, only an RCD or RCM of Type B is allowed on the supply side of this product.

7.4.2.1 General

When the controller operates in hybrid mode, it is combining solar power and AC power. For that reason both power sources are galvanically connected together, which means always both power sources must be safely disconnected during installation or maintenance.

To be able to use both power sources in hybrid mode, the PV voltage (real Vmp) must be higher than the AC input voltage after it has internally been rectified to DC.

AC input voltage	min. real Vmp from PV generator
380 V AC	535 V DC
400 V AC	565 V DC
460 V AC	650 V DC
480 V AC	680 V DC

For installing a hybrid system, ensure the steps in „7.4.1 Controller wiring for solar only“ on page 29 have been completed before proceeding.

7.4.2.2 Electrical installation

It is the installers' duty to correctly install the AC components like cable, AC disconnect/breaker and AC fuses. The installation must comply with local installation requirements and conditions.

Depending on the installation parameters and size of system it might not be possible to install an RCD or RCM as normal leakage currents could lead to tripping in normal operation. If the use of an RCD is required the installer needs to take care to install a custom solution according to local standards.

7.4.2.3 Input current and harmonics

Due to its rectifier operation the AC input of the PSk3 draws a non-sinusoidal current (harmonic currents) from the supply source. This slightly increases the maximum current value compared to pure sinusoidal currents.

The absolute value of the current depends on grid impedance and grid voltage. Technical data calculation in „4.2 Technical Data of the PSk3 Controller“ on page 12 was calculated based on a 400 V three-phase grid with a relatively low grid impedance (strong grid).

If you connect the PSk3 to an oversized generator or a strong grid it can draw a maximum RMS current of up to 30 A per phase (see „4.2 Technical Data of the PSk3 Controller“ on page 12) when supplying a 11 kW motor at full power.

All components of the installation have to be sized according to this maximum current value.

If you are connected to a public grid where there are requirements concerning maximum Harmonic Distortions, you might need to install filters at the AC input of the PSk3 to fulfill local standards requirements. Installing filters also reduces the RMS current, which the PSk3 controller draws from the AC source. More information about line and load filter can be found on partnerNET.

7.4.2.4 Wiring

The following cable sizes are minimum recommendations depending on the size of PSk3 system being used.

Table 8: Min recommended cable sizes

PSk3 system	AC input cable
PSk3-7	2.5 mm ² /AWG 14
PSk3-15	6 mm ² /AWG 10

According to the technical data of the controller, the technical rules of the country of installation are to be applied for the cable selection taking into account the cable length, temperature and type of installation. The specified conductor cross-sections in table are minimums. For further information on max. Input AC current refer to „4.2 Technical Data of the PSk3 Controller“ on page 12.

The values in the table are for ambient temperatures of up to 30°C. If you expect higher temperatures, use the next larger cable size.

Ensure all terminals are tightened.

7.4.2.5 Fuses

The PSk3 does not include AC fuses. The AC input supply must be equipped with an appropriate fuse. „Table 2: Technical Data of the PSk3 Controller“ on page 12 states the rated AC input current based on a 400 V three-phase grid and shall not be exceeded. For all PSk3 controller sizes the fuse types “gR” or “gS” are recommended. For PSk3-7 the rated fused current needs to be 20 A, for PSk3-15 the rated fuse current needs to be 35 A. In case the locally available supply AC voltage is higher than 400 V, the used fuses need to comply with the higher voltage. The current ratings for each controller type are valid for higher voltages as 400 V, too.

Circuit breaker

The PSk3 does not include an AC fuse or circuit breaker. A manual disconnection device is required to isolate the PSk3 from the AC source and allow installation and maintenance.

Reasons to open the AC circuit breaker:

- Working on the controller (installation or maintenance)
- Working on solar array (additionally open DC disconnect switch)
- Working on the motor

7.4.2.6 Grid Operation

PSk3 is designed to work with a grid voltage range of 380 to 480V +/- 10% and a frequency-range of 45 to 65 Hz.

Before connecting to the grid and during operation PSk3 is monitoring the voltage range of the grid and connects if the grid voltage is in range.

If voltage fluctuations occur due to an unstable grid, PSk3 will not connect or shut down its operation, as unstable grid can damage components inside PSk3.

 **NOTE** – If the controller is installed in an environment with an unstable grid, the controller will shut down or not even start to protect its components from damage.

NOTE – If the controller is used in hybrid operation the solar array must not be grounded.

Figure 13: PSk3 controller for connection of hybrid operation, top view

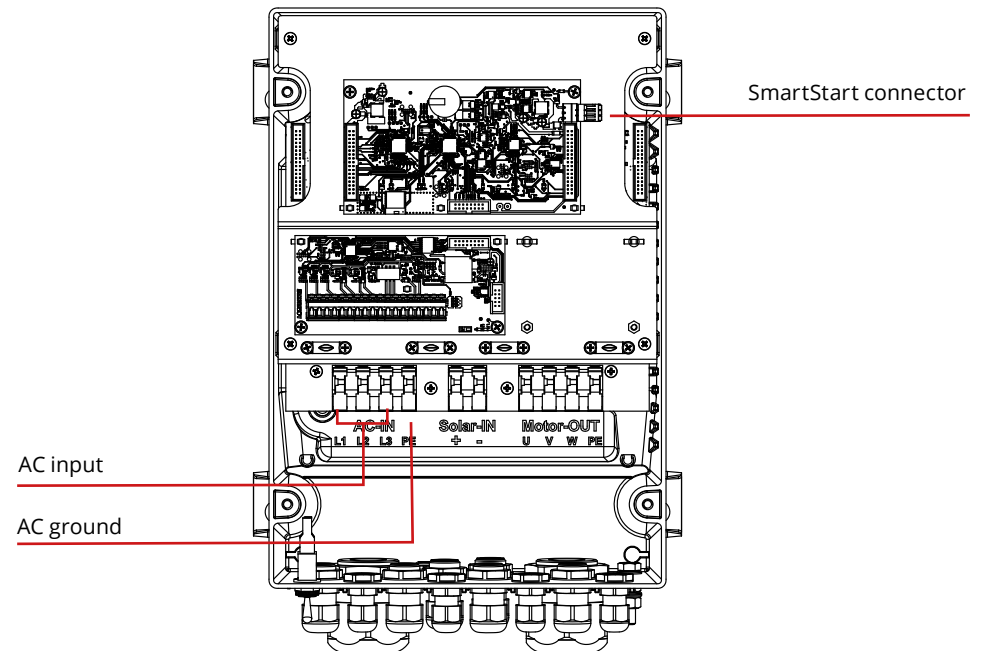

7.4.2.7 Further considerations

As AC source and solar are coupled galvanically to each other it is important to always disconnect both sources if installation or maintenance has to be done on either the AC or DC side.

If you are working on the AC power lines, take care that the DC power lines are disconnected. If you are working on the DC power lines, the AC power lines need to be disconnected for safety reasons. It is recommended to attach a warning to your installation components, e.g. to an installed PV Disconnect.

During nighttime it is possible that voltage is present on the solar array. This voltage is parasitically induced if controller is connected to AC during nighttime.



WARNING – Beware of dangerous voltage on the PV array, even at night!

7.5 Grounding

7.5.1 Why grounding is required

Grounding is mandatory to protect the users from potentially fatal electric shocks. It also protects against electric charging or a short circuit inside the device. This is accomplished through clamping, bolting or other mechanical means to provide an effective grounding path to the earth to ensure safe operation at all time.

The grounding is also important to the system for lightning protection. In general it is meant for indirect lightning strikes and induced electrical potentials during operation of the pump system.

7.5.2 How to ground

A protective earth connection for the controller must be connected to the grounding bolt. The right PE terminal, next to the motor phases (U, V, W), is for the protective earth wire of the motor.

7.5.3 Insufficient ground source

Where there is an inadequate ground source you can use a grounding rod. A grounding profile rod should be located about 4 – 5m (13 – 16 ft) maximum from the controller. The cable must not carry any mechanical loads. The rod must be completely buried in the ground (0.5 m / 1.5 ft below ground level). You must refer to local standards and requirements. The grounding cable should be a copper cable with a cross section of not less than 16 mm² (AWG 6).

Figure 14: Controller grounding

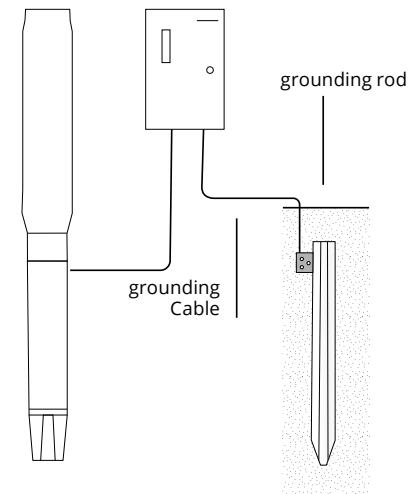
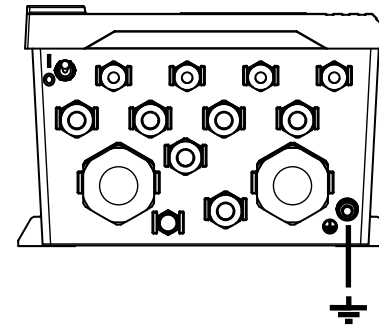

Figure 15: Grounding cable mounting at controller housing

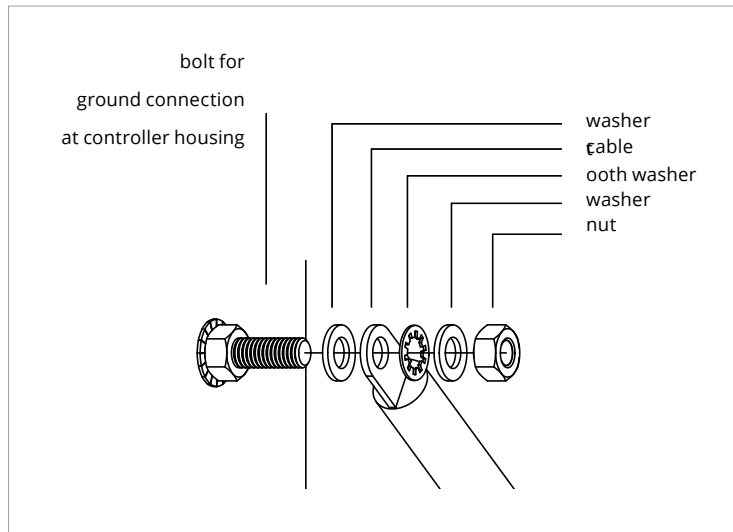
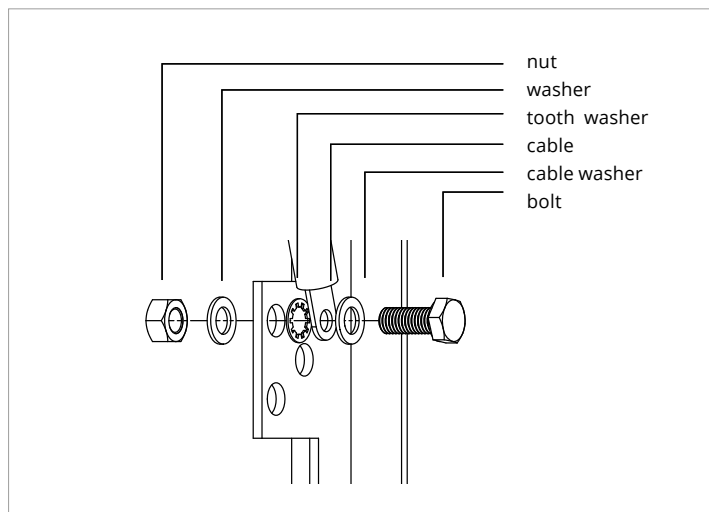

Figure 16: Grounding cable mounting at grounding profile rod



8 Pump Installation

8.1 General instructions

WARNING – All electrical connections must be performed by qualified experts only.

WARNING – Before starting any work on the pump/motor, make sure that the electricity supply has been switched off and that it cannot be accidentally switched on!

CAUTION – Before you start the assembly, make sure that all parts were delivered and have not been damaged during transport.

For surface pumps:

WARNING – Psk CS pumps must NOT be submerged in water or subjected to rain or dripping water.

WARNING – If the pump is installed in a humid area, effective ventilation and aeration must be provided in order to prevent condensation.

WARNING – When installing in very small installation spaces the natural cooling may be insufficient. Carefully consider the ventilation in order not to exceed the maximum environmental temperature.

WARNING – The pump might heat up in operation. The pump must not be installed on combustible surfaces. Strong incombustible surfaces should be used e.g. concrete or stone surfaces.

8.1.1 Pipe sizing

LORENTZ pump systems are extremely efficient. It is important to keep this efficiency throughout the entire system. A main reason for loss of efficiency is pipe pressure losses. Make sure that you have included the pipe pressure losses during the sizing process of your system.

Consider a smart pipeline design from the beginning. If possible use high-quality HDPE-pipes. If you are not sure about the strength of your pipes contact the pipe manufacturer.

CAUTION – Consult COMPASS or a pipe pressure sizing chart to determine the correct size. Oversize the pipe line to reduce the pressure drop.

CAUTION – The length of the inlet and of the outlet pipeline must be considered for the calculation of the pressure losses.

CAUTION – Only run the pump when it is completely prefilled with water (surface pumps), submersible pumps must be completely submerged. This means there must be no air in the pipes.

CAUTION – For surface pumps, air locks must be avoided at the inlet pipe line. Avoid sharp 90° elbows and sharp pipe size adaptors (see also "Figure 17: Prevent air locks in pipes" on page 50 and "Figure 18: Avoid sharp 90° elbows and size adaptors" on page 50).

CAUTION – When you use plastic pipes you must use a safety rope.

For surface pumps:

Figure 17: Prevent air locks in pipes

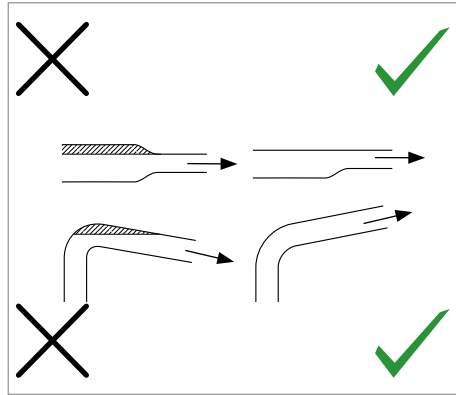
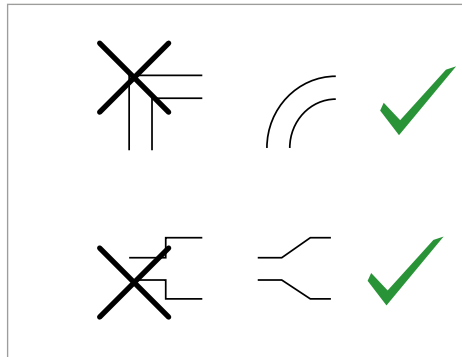

Figure 18: Avoid sharp 90° elbows and size adaptors



8.1.2 Cable Splicing

To connect the motor cable with a cable extension you should connect the cable ends with a splicing kit.

It is very important that the cable joints are fully sealed otherwise moisture could cause a short circuit. This will damage the pump system.

For more information about connecting cable ends with a splicing kit see the “submersible cable splicing” manual in the package of the splicing kit.

CAUTION - Cable splice failures are a common source of errors. Check the splice for proper connections.

CAUTION - Bad cable splicing can damage the controller and/or the pump. Such damage is excluded from the warranty.

8.2 Submersible Pumps

8.2.1 System Layout: Submersible Pumps

CAUTION - This graphic is an example pump system layout diagram and for ease of understanding only. For system installation and wiring read and follow the detailed instructions given in this manual.

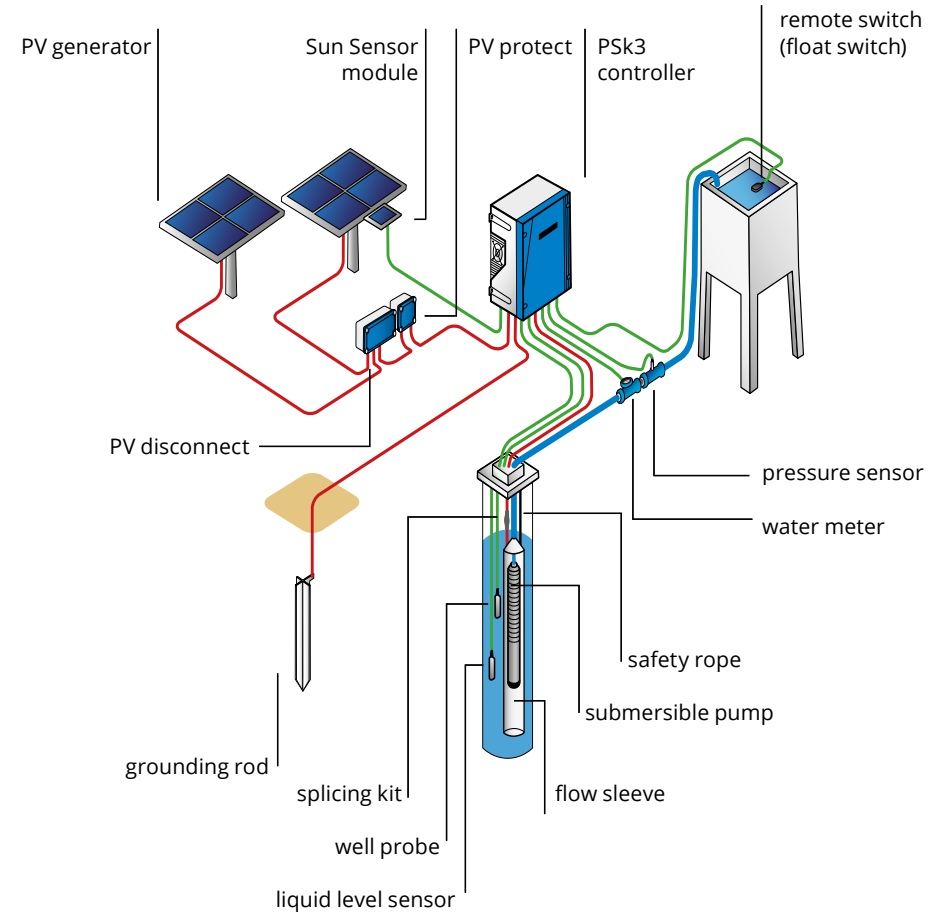

The submersible motor is factory-filled with water, but the motor filling must be checked before installation.

The motor must be filled in vertical position (coupling showing upwards, see figure below, "Figure 19: Filling, venting and drainage hole").

To fill the motor with water, remove the filling and venting screw. Fill clean drinking water into the motor until the water flows out continuously out of the venting hole, without any bubbles.



NOTE – Do not fill the motor using a high pressure source such as a tap or hose as this will cause unwanted bubble formation.

To refill the motor open the filling, venting and drainage screws to allow water to exit from the drainage hole. Close the drainage screw and fill the motor with clean drinking water as described above.

Figure 19: Filling, venting and drainage hole

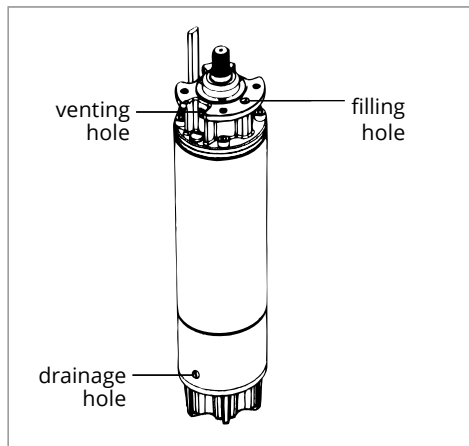

8.2.2 Wiring the pump



CAUTION – No disconnect switches must be installed between the motor and the pump controller. Connecting the motor wire to the switched-on controller might irreparably damage it. Such damage is excluded from the warranty.

CAUTION – If the pump wires are in the wrong order, the motor will run in reverse and the pump will not function correctly. Damage may result. Check the direction before installing the pump. The proper direction is counterclockwise when viewed from above.

CAUTION – Never let the pump run dry. Dry running will damage the pump and void the warranty. LORENTZ requires dry run protection for every submersible pump system.

The motor cables of the pump have a marking to allow correct wiring. Connect the wires using this sequence:

- U: Motor cable phase 1
- V: Motor cable phase 2
- W: Motor cable phase 3
- ⊕: GND

The submersible pump must be submerged in water before checking the correct rotational direction. The correct rotation direction for submersible pumps is counterclockwise, viewed from the top. It is also labelled with an arrow on the pump end.

Centrifugal Pumps:

Check of rotation direction after submersible pump installation:

- (5) Connect the pump to the controller and power supply.
- (6) Start the pump and check the delivered flow rate.
- (7) Stop the pump, disconnect the power supply and change two of the three phase leads
- (8) Start the pump again and check the delivered flow.
- (9) Stop the pump, disconnect the power supply and compare the flow rates from point 2 and 4. The wiring with the better flow rate has the right rotational direction.

Figure 20: Example LORENTZ PSk3 submersible pumps



8.2.3 Resistance measurement

We recommend checking the winding and insulation resistance before connecting the pump to the controller. For a submersible pump these measurements should be done **BEFORE** lowering the pump into the well.



WARNING – Before starting any work on the pump system, make sure that the electricity supply has been switched off and that it cannot be accidentally switched on!

To measure the winding and insulation resistance disconnect all motor leads from the controller. A good quality multimeter is necessary to measure the phase-to-phase resistance with an accuracy to the first decimal place. ("0.1 Ohms"). It is also advisable to consider the resistance of the multimeter leads when measuring very low values:

- Hold the tips of the multimeter together and note the value.
- Always subtract this value from your motor resistance measurements!

Winding resistance

- (1) Set the multimeter to "resistance measurement" and select the lowest measuring range.
- (2) All PSk3 motors are 3-phase motors. Measure the resistance of phase-to-phase: 1-2, 2-3, 3-1. Make sure there is good contact between the probes and the cable.
- (3) The deviation between the phases should be within 10 %. If the deviation is too high, the reason is likely a damaged submersible cable or a faulty cable splice.
- (4) The absolute value is made up of the resistance of the motor winding and the submersible cable. The resistance of the submersible cable depends on its length and size. For copper cable, the values of the table below, "Table 9: Motor cable resistance" and "Table 10: Motor resistances for submersible pump motors" on page 55 can be used as approximation.

Table 9: Motor cable resistance

Cable	Resistance [Ω / 100 m]
2.5 mm ² / 13 AWG	0.82
4 mm ² / 11 AWG	0.51
6 mm ² / 9 AWG	0.34
10 mm ² / 7 AWG	0.20
16 mm ² / 5 AWG	0.12

Example:

- Motor: AC DRIVE SUB 6" 7.5 kW → 1.8 Ω
- Motor cable: 150 m and 6 mm² → 0.25 Ω / 100 m

Calculation of expected phase-to-phase resistance:

$$= 1.8 \Omega + 2 \times 150 \text{ m} \times 0.25 \Omega / 100 \text{ m}$$

$$= 1.8 \Omega + 2 \times 0.375 \Omega$$

$$= 1.8 \Omega + 0.75 \Omega$$

$$= 2.55 \Omega$$

$$= \sim 2.6 \Omega$$

The real measured values can be different, depending on the measurement equipment and materials that are used. This is just an approximation.

Insulation resistance

Use a megohmmeter at 500 –1,000 V.

Measure each phase to ground. Connect one test prod to the phase hold the other test prod to the pipe work, or if plastic pipes are used to the ground wire.

If the insulation resistance is below 0.5 MΩ, the motor cable must be checked for damage.

Table 10: Motor resistances for submersible pump motors

Submersible Pump Motors	PSk3 system	Phase-to-phase resistance [Ω]
AC Drive Sub 6" 5.5 kW	PSk3-7	2.4
AC Drive Sub 6" 11 kW	PSk3-15	1.3

8.2.4 Preparing the installation

To lower the pumps into the borehole, a crane or hoist is required. You also need two clamps and ropes to lift components.

All parts have to be strong enough to withstand the weight of the pump, the motor, the motor cable and the pipe system.

It is also helpful to lower a pump dummy into the borehole before you lower the pump to make sure that the hole is completely free and the pump can slide into the hole without obstructions.

 **WARNING** – Before starting any work on the pump/motor, make sure that the electricity supply has been switched off and that it cannot be accidentally switched on!

WARNING – Never stand under suspended loads.

 **CAUTION** – Before starting the assembly, make sure that all parts are delivered and have not been damaged during transport.



CAUTION – Pay attention to the label on the motor if the liquid in the motor need to be checked, filled up or if the motor needs to get completely refilled.

CAUTION – Be careful not to bend the pump, take particular care with pumps with higher numbers of stages. Make sure that the pump never stands on the motor cable, that the cable does not get jammed or damaged by sharp ledges or that the cable is not pulled or jerked where it enters the motor.

During the process of lowering the pump into the well the motor cable has to be fixed properly to the pipe, see "Figure 21: Fixing of the motor cable at a joint and a strait pipe" on page 56.

Where a plastic pipe is used, the longitudinal stretch of the pipe under load has to be considered by leaving a sufficient gap between the pipe and the cable!

The cable should be fixed with water-resistant tape. It is a good installation practice to form a loop with the motor cable near the pump and repeat it about every 40 m / 130 ft along the riser pipe. This will keep any tensile forces away from the motor cable.

To extend the motor cable pay attention to chapter „8.1.2 Cable Splicing“ on page 50.

Round off the edges of a flange to prevent damage to the cable. Do not fix the cable tightly. Leave space for the pipes to expand. The cable needs to get fixed every 3 m.

Figure 21: Fixing of the motor cable at a joint and a strait pipe

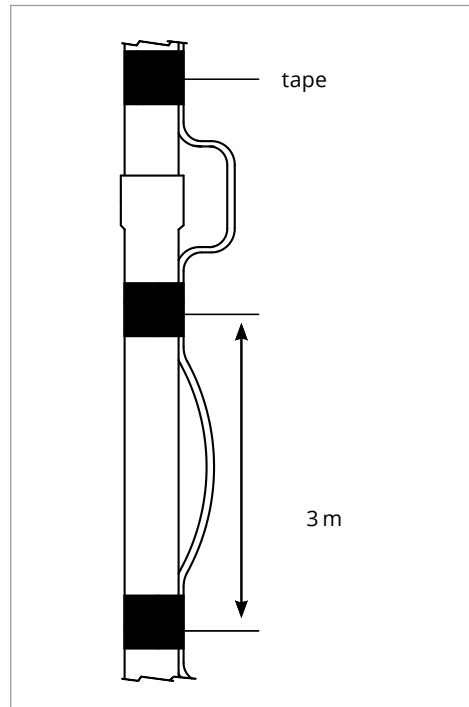

NOTE - Measuring and noting down the distances between the fixing will help to lower the pump to the right depth.

8.2.5 Installation Depth

Make sure that the pump unit is suspended properly and is not in contact with sand and mud from the well bottom. It is recommended to install the pump above the filter zone (= water entry zone) of the well to keep the sand content in the water low and ensure proper cooling of the motor, see also "Figure 22: Installation depth" on page 57.

CAUTION - The pump must be submerged completely. Never let the pump run dry. Dry running will damage the pump and void the warranty. LORENTZ prescribes a dry run protection for every pump system.

CAUTION - If the pump does not hang above the filter zone a flow sleeve is necessary.

Figure 22: Installation depth

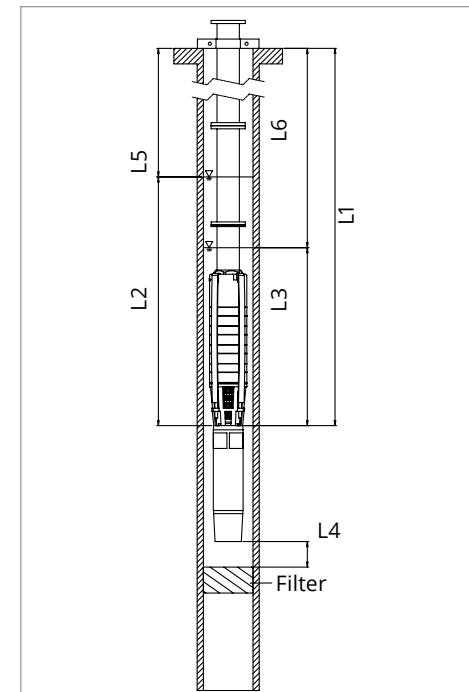

8.2.6 Removal

If you have to remove the pump system it is the same principle as the installation in reverse order. When removing the pump the pipes will be full of water and will be heavier.

CAUTION - When you lift the pump system out of the well the pipes are full of water. This causes additional weight.

In the table below you can see the additional weight of the water per meter pipe length.

Table 11: Additional weight per meter pipe length

Pipe diameter	Additional weight		
	[in]	[kg/m]	[lb/ft]
2		2.0	14.5
2.5		3.2	23.1
3		4.6	33.3
4		8.2	59.3
5		12.7	91.9
6		18.4	133.1

- L1: Installation depth
- L2: Max immersion depth = 150m
- L3: Min immersion depth = 1m
- L4: Distance to filter
- L5: Depth to highest water level
- L6: Depth to lowest water level

8.2.7 Installation

To connect the pump end and the motor you have to set the motor with the clamps in the borehole to fix it, see also figure below, "Figure 23: Motor in borehole".

Make sure that the clamps rest on a sufficient stable support structure, for example the well casing. If the structure is not strong enough to carry the weight a support structure has to be built that is suitable for the installation process.

Screw the first piece of the pipe into the pump and install a second clamp at the pipe, see also figure below "Figure 24: Preassembly of the pump" on page 58.

CAUTION - Make sure that the motor cable is outside the clamps, otherwise you will damage the cable.

NOTE - Do connect the clamp directly under the flange to leave some space for mounting the bolts.

If threaded joints are used instead of flanges they must fit together to ensure that they do not work loose when subjected to the torque reaction caused by the starting and stopping of the pump.

Figure 23: Motor in borehole

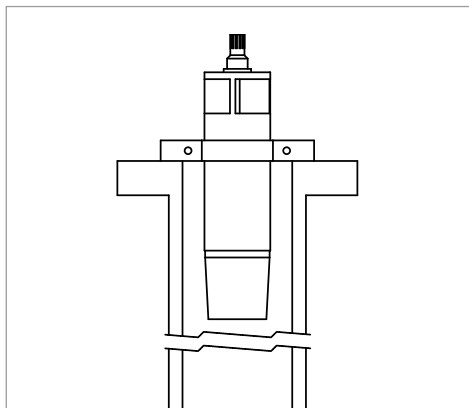

The thread on the first section of the riser pipe which is to be screwed into the pump should not be longer than the threads in the pipe, see also „Figure 25: Installation depth of the first piece of pipe“ on page 58.

Figure 24: Preassembly of the pump

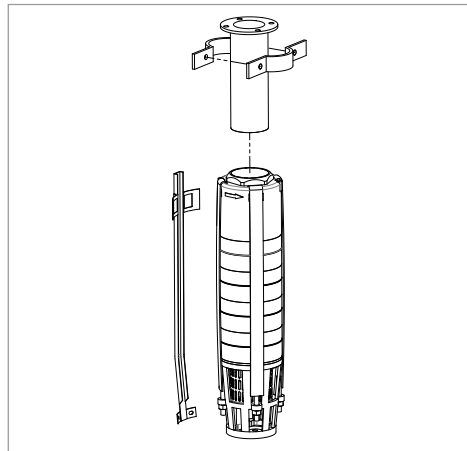
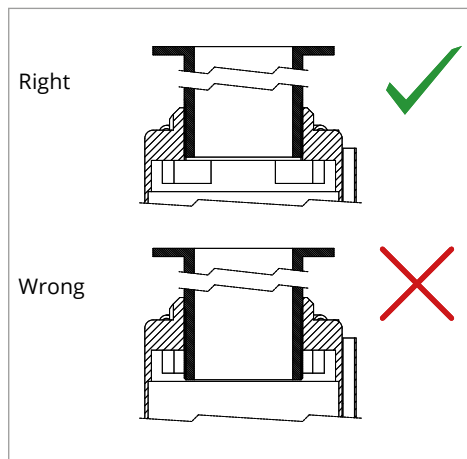

Figure 25: Installation depth of the first piece of pipe



CAUTION - When you fit the pipe into the pump hold the pump only at the top chamber!

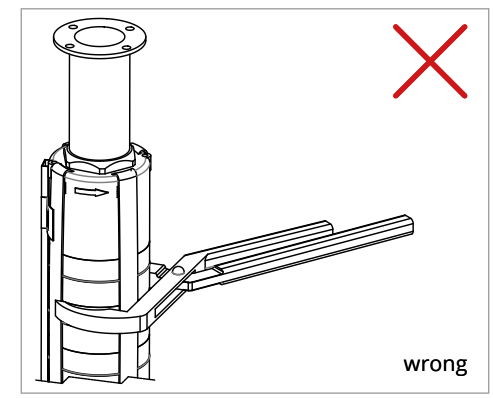
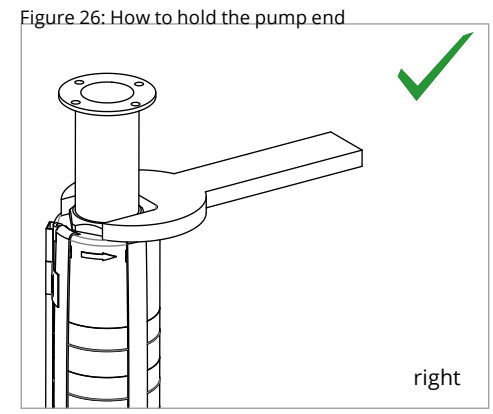
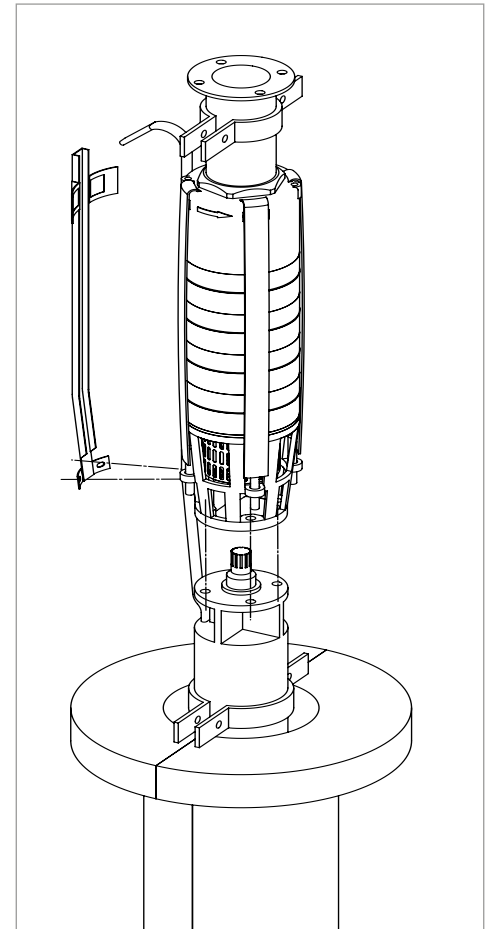

Figure 27: Connection pump end with motor



Lower the pump end carefully onto the motor and fix it with the supplied screws. It is very important to avoid heavy impact when the pump end is mounted onto the motor.



CAUTION - Impact between the pump end and motor can damage the pump system.

CAUTION - The NEMA coupling of the motor and the pump end must be **CLEAN** when the pump end is mounted onto the motor.

For correct connection pay attention to the following table with tightening torques. The screws must be tightened diagonally.

Table 12: Tightening torques for pump/motor connection

Pump / Motor	Torque [Nm]	Torque [lb × ft]
M8	18	13
M12	70	52
M16	150	110

When pump end and motor are assembled, lift the pump unit a little and remove the lower clamp on the motor. Now lower the pump carefully downwards into the bore hole until the upper pipe clamp is resting properly on the support structure. Be careful not to allow the pump to hit the side of the well or this may cause damage.



WARNING - Always take suitable security precautions (like a strong safety rope) to safeguard the pump against slipping into the well during installation!

Figure 28: Dismantling the lower clamp

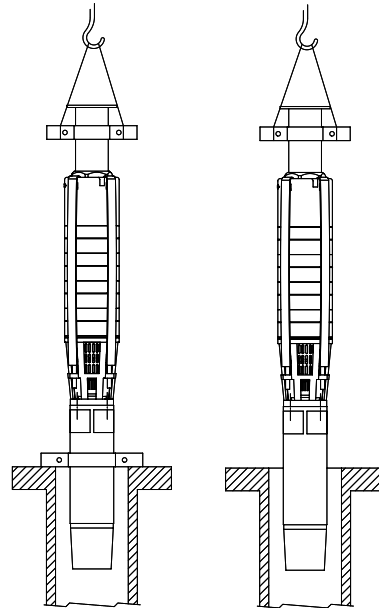

Now the next piece of clamped pipe can be mounted onto the flange/connector of the previous one. Only use suitable bolts and sealing material. ("Figure 29: Connecting the next piece of pipe" on page 61)

Figure 29: Connecting the next piece of pipe

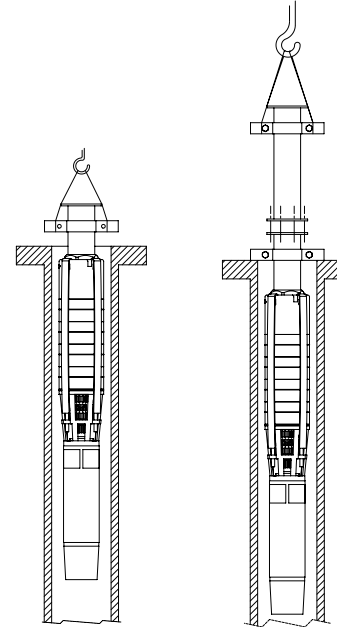

After connecting the two pipes, lift the whole pump system again to dismantle the lower clamp above the pump end. This procedure has to be followed for every piece of pipe until the pump has reached the desired installation depth.



WARNING - If the pump is not lifted before the clamp is being dismantled the pump will sag. This could cause serious injuries to the installer and damage to the pump system.

Figure 30: Dismantling the lower clamp

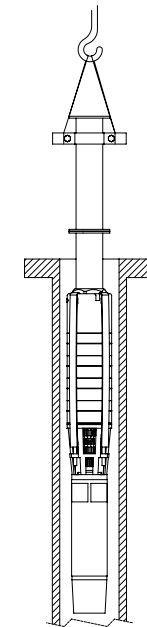

NOTE - Pay attention to "8.2.4 Preparing the installation" on page 55 and "8.2.5 Installation Depth" on page 57.

8.2.8 Pipes with thread

If you use pipes with a thread instead of a flange the installation is basically the same.

The threads have to be sealed with hemp- or teflon tape. Make sure that the threads cannot work loose over time.

8.2.9 Additional Features

8.2.9.1 Safety Rope

We recommend the use of a safety rope as a loss insurance. If the pipe breaks because of start-up torques of the motor, too much weight, pipe corrosion or wrong installation, a safety rope can prevent the total loss of the pump system and damage to the well.

Choose a safety rope that can handle the weight of the whole installation and the water inside the pipes. The rope material must be water-resistant. Near the well head the rope needs to be UV-resistant or protected from sunlight.

CAUTION - Do not use a nylon rope. Nylon is known to absorb water over time which will weaken the rope.

8.2.9.2 Plastic pipes

When the pipes are strong enough, the use of plastic pipes is possible. If you are not sure about the strength of your pipes contact the pipe manufacturer.

CAUTION - The pipes must be strong enough to hold the whole weight of the pump, the motor, the pipe system and the water in the pipes. It must also withstand the water pressure generated by the total dynamic head.

CAUTION - When using plastic pipes you should always use a safety rope.

8.2.9.3 Flow sleeve

All LORENTZ PSK3 submersible pumps are designed for the use of water with a temperature between 0°C and 30°C.

The minimum liquid velocity past the motor is 0.16 m/s.

CAUTION - Where the stated liquid velocity cannot be achieved, a flow sleeve must be installed.

For the maximum recommended sand content, before any significant detrimental effects occur, check chapter "4.3 Technical requirements for the pumps" on page 13.

Figure 31: Operation of a flow sleeve

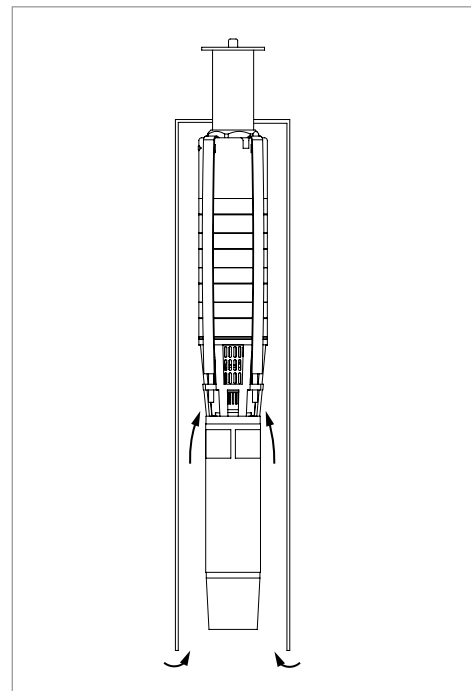

A higher content will cause excessive wear within the pump and reduce the pump's life span considerably. Any pump that is blocked by sand will not be covered by warranty.

8.3 Surface Pumps

CAUTION - This graphic is an exemplary pump system layout diagram and for ease of understanding only. For system installation and wiring read and follow the detailed instructions given in this manual.

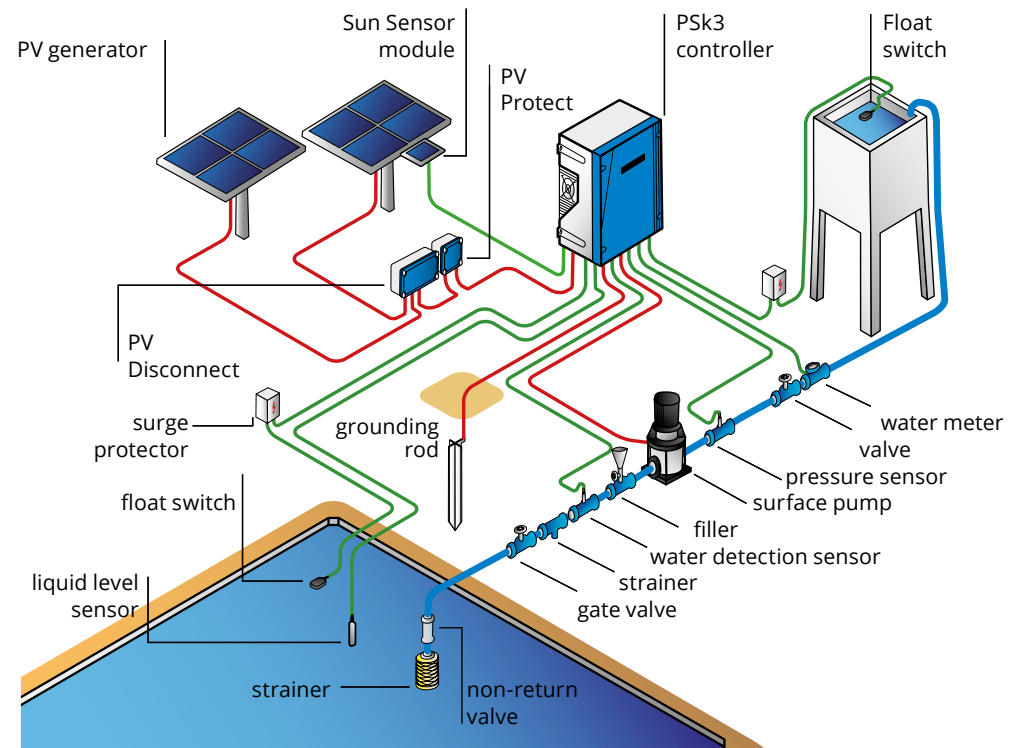

8.3.1 Placement and Foundation

Rain and weather protection – The pump is equipped with IPX4-type motor protection. If it is installed outside, the pump must be protected from rain and direct sunlight. This will increase the durability of your pump.



CAUTION – CS-F and CS-G pumps must not be submerged in water or subjected to rain or dripping water.

CAUTION – If the pump is installed in a humid area, effective ventilation and aeration must be provided in order to prevent condensation.

CAUTION – When installing in very small installation spaces the natural cooling may be insufficient. Carefully consider the ventilation in order not to exceed the maximum ambient temperature.



CAUTION – The pump might heat up in operation. The pump must not be installed on combustible surfaces. Strong incombustible surfaces should be used, e.g. concrete or stone surfaces.

Foundation – An arrow on the pump base shows the direction of the flow of the fluid through the pump. It is recommended to install the pump on a concrete foundation. The foundation must be level and should have min. approx. 1.5 times the weight of the pump to absorb vibration, shock and strain.

Connecting the pump to the foundation – Fastening the pump to the foundation should be done exclusively by means of properly sized bolts or threads (dowels) in order to avoid any movement of the pump unit.



CAUTION – The pump must be mounted vertically.

CS-G pumps are supplied along with a base plate that has to be mounted to the bottom of the pump. Use only the screws that are supplied with this base plate, do not install this pump without this base plate.

Space – During installation, make sure that there is enough space available to permit subsequent disassembly of the motor unit. It is recommended to have at least 1m of free space above the pump.

8.3.2 Motor wiring

8.3.2.1 Connecting the motor cable

The surface pump motor has a wiring box that contains the connection terminals for the three motor phases.

The pump motor provides bolt terminals to connect the motor cable. For a professional and reliable connection it is required to use cable lugs for connecting the motor cable to the bolt terminals.

The motor phases are labeled with "U", "V", "W".



CAUTION – The wiring order will have impact on the motor rotation direction. The correct rotation direction is marked with an arrow sticker on the pump and motor.



CAUTION – Observe the rotation direction of the pump when the system installation is finished and the pump has been successfully primed with water.

In case the rotation direction is incorrect exchange any two of the three motor phases to reverse the rotation direction.

8.3.2.2 Resistance measurement

We recommend checking the winding and insulation resistance before connecting the pump to the controller. For a surface pump these measurements should be done BEFORE taking the pump into operation.



WARNING – Before starting any work on the pump system, make sure that the electricity supply has been switched off and that it cannot be accidentally switched on!

Figure 32: Example LORENTZ PSk3 surface pumps



To measure the winding and insulation resistance disconnect all motor leads from the controller. A good quality multimeter is necessary to measure the phase-to-phase resistance with an accuracy to the first decimal place. ("0.1 Ohms"). It is also advisable to consider the resistance of the multimeter leads when measuring very low values:

- Hold the tips of the multimeter together and note the value. Always subtract this value from your motor resistance measurements!

Winding resistance

- (1) Set the multimeter to "resistance measurement" and select the lowest measuring range.
- (2) All PSk3 motors are 3-phase motors. Measure the resistance of phase-to-phase: 1-2, 2-3, 3-1. Make sure there is good contact between the probes and the cable.
- (3) The deviation between the phases should be within 10%. If the deviation is too high, the reason is likely a damaged submersible cable or a faulty cable splice.
- (4) The absolute value is made up of the resistance of the motor winding and the submersible cable. The resistance of the submersible cable depends on its length and size. For copper cable, the values of the table "Table 13: Motor cable resistance" and "Table 14: Motor cable resistances for surface pump motors" on page 67, can be used as a rough approximation.

Table 13: Motor cable resistance

Cable	Resistance [Ω / 100 m]
4 mm ² / AWG 11	0.40
6 mm ² / AWG 9	0.25
10 mm ² / AWG 7	0.17
16 mm ² / AWG 5	0.10
25 mm ² / 4 AWG	0.066
35 mm ² / 2 AWG	0.047
50 mm ² / 1 AWG	0.033
70 mm ² / 2/0 AWG	0.023
95 mm ² / 3/0 AWG	0.018

Example:

- Motor:
AC DRIVE CS-F 7.5 kW \rightarrow 1.4 Ω
- Motor cable:
150 m and 6 mm² \rightarrow 0.25 Ω / 100 m

Calculation of expected phase-to-phase resistance:

$$\begin{aligned}
 &= 1.4 \Omega + 2 \times 150 \text{ m} \times 0.25 \Omega / 100 \text{ m} \\
 &= 1.4 \Omega + 2 \times 0.375 \Omega \\
 &= 1.4 \Omega + 0.75 \Omega \\
 &= 2.15 \Omega \\
 &= \sim \mathbf{2.2 \Omega}
 \end{aligned}$$

The real measured values can be different, depending on the measurement equipment and materials that are used. This is just an approximation.

Insulation resistance

Use a megohmmeter at 500–1,000 V.

Measure each phase to ground. Connect one test prod to the phase hold the other test prod to the pipe work, or if plastic pipes are used to the ground wire.

If the insulation resistance is below 0.5 M Ω , the motor cable must be checked for damage.

Table 14: Motor cable resistances for surface pump motors

Surface pump CS-F motors	PSk3 system	Phase-to-phase resistance [Ω]
AC DRIVE CS-F 5.5 kW	PSk3-7	1.4
AC DRIVE CS-F 7.5 kW	PSk3-9	1.4
AC DRIVE CS-F 11 kW	PSk3-15	0.8
Surface Pump CS-G Motors	PSk3 system	Phase-to-phase resistance [Ω]
AC DRIVE CS-G 5.5 kW	PSk3-7	1.7
AC DRIVE CS-G 7.5 kW	PSk3-9	1.3
AC DRIVE CS-G 11 kW	PSk3-15	0.8
AC DRIVE CS-G 11 kW/4p	PSk3-15	0.8

8.3.3 Installation and Handling

Handling – When lifting the CS-F pump use the eyebolts at the motor housing. CS-G pumps must be lifted by the base. Use the eyebolts to stabilize the pump, see also "Figure 33: Pump handling/lifting" below. It is recommended to use suitable lifting sling belts.

Figure 33: Pump handling/lifting

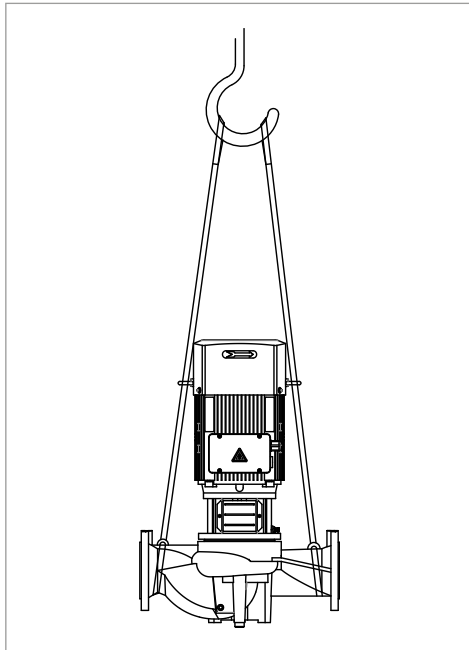

Strainer – If pipelines are welded together metal pieces might be present in the pipeline. Before pump installation, the inlet pipeline must be carefully cleaned. It is recommended to install a strainer about 1 m / 3 ft in front of the pump inlet to avoid pump damage due to any kind of impurities (see also "Figure 34: Strainer" on page 68). The pressure drop of the strainer must be considered in the suction head calculation. Please refer to COMPASS and the corresponding LORENTZ knowledge base article.

Figure 34: Strainer

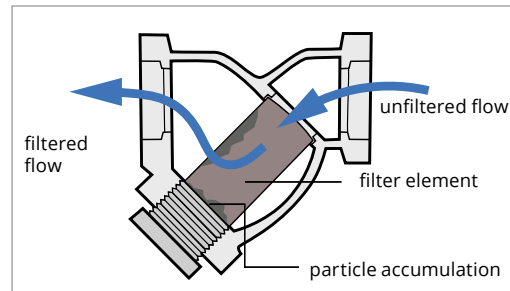

Pipe system – We advise that pipe expansion joints are used close to the pump on both inlet and outlet to reduce noise and vibration (see also "Figure 35: Pipe expansion joints" on page 68). It is recommended that you install a gate valve in the suction and discharge pipeline close to the pump to avoid draining of the pipe while cleaning (e.g. filters), repairing, servicing or replacing the pump system.

Figure 35: Pipe expansion joints

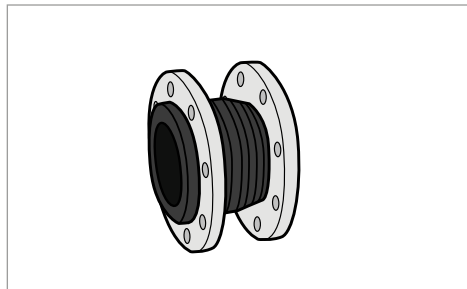

WARNING – Inlet and outlet pipes must be mounted to the pump housing free of tension.



CAUTION – Make sure that the suction pipe is sealed with no leaks, otherwise the pump will not prime or will prime insufficiently.

CAUTION – The pumps are shipped with plastic covers on the pump inlet and outlet. Remove them before connecting the pipes to the pump.

Check valve – A check valve at the inlet pipe is needed to assure that the pump and its suction pipeline remains completely water filled during the time the pump is switched OFF. Always install a check valve with one inch (1") larger diameter than the suction pipe in order to avoid too much suction pressure drop. For example if the suction pipe size is 3", then a 4" check valve should be installed.

8.3.4 Suction Head

The maximum suction head is limited by the local air pressure, the water temperature of the medium, the pipe losses and the NPSH (net positive suction head) value of the pump.



CAUTION – If the suction pressure in the pump is lower than the vapor pressure of the fluid, cavitation will occur. Cavitation creates noise and will damage the pump. Damage due to cavitation is not subject to warranty. To avoid cavitation, the pressure of the fluid must be maintained above its vapor pressure at all points as it passes through the pump.

The maximum suction head (H) must be calculated in advance. Please refer to COMPASS and the corresponding LORENTZ knowledge base article for NPSH calculation.

8.3.5 Initial Start-up



CAUTION – Never start the pump if it is not filled with water and has not been vented. The pump and suction pipe must be fully filled with clean water otherwise the pump will be damaged.

8.3.5.1 Filling Pump with Water

The pump and the whole suction pipe must be fully filled with clean water.

If the water level is higher than the pump inlet:

1. Close the gate valve in the outlet pipe and loosen the air vent screw.
2. Open the gate valve in the suction pipe slowly.
3. Tighten the air vent screw when water streams out continuously.

If the water level is below the pump inlet:

Suction pipeline and pump must be filled with water.

1. Close the gate valve in the outlet pipe and open the gate valve in the suction pipeline.
2. Loosen the air vent screw and fill the water into the pump through the filler pipe.
3. Fasten the air vent screw after the pump and the suction pipeline are completely filled with water.



CAUTION – Installing a suitable filler pipe is highly recommended for proper priming of the pump system. A pump system which is not primed completely will likely get damaged when it is switched on.

CAUTION – A nonreturn valve must be installed at the start of the inlet pipeline otherwise it is impossible to prime the pump successfully.



WARNING – Do not start the pump until it has been filled completely with water.

WARNING – Make sure that the installed shutoff valves in the suction and pressure lines are completely open during operation, the pump must never run with shutoff valves closed!

8.3.5.2 Rotary direction



CAUTION – Never let the pump run dry, not even for the purpose of checking the direction of rotation! Dry running will damage the pump and void the warranty.

Switch on the power supply and look at the rotary direction by looking at the motor fan. An arrow on the pump unit indicates the correct direction of the rotation.

Viewed from the top, the pump turns counterclockwise.

8.3.5.3 Final Check-up

Check whether the foundation bolts are fastened, the pump and suction pipes are completely filled with water, the voltage of the power supply is correct and that the pump turns correctly. Make sure all pipelines are connected tightly and can supply water normally. Make sure there is no closed valve or other obstruction in the water line.

9 Pump Accessories Installation

Pumps can be installed with a range of protective and enhancing accessories. For an overview, please also refer to "Figure 2: Submersible pump layout" on page 20 and "Figure 3: Surface pump layout" on page 21.



CAUTION – Installing a SunSensor is mandatory for all PSk3 CS-F and CS-G series solar pump systems. Operating without a SunSensor can lead to increased wear or damage the pump. Such damage is excluded from the warranty.

CAUTION – Never let the pump run dry. Dry running will damage the pump and void the warranty. LORENTZ requires a dry run protection for every pump system.

CAUTION – Installing a surge protector at all switch inputs is recommended, damaged inputs due to electric surges are not covered by the warranty.

9.1 Well probe

The well probe, see also "Figure 37: Well probe" on page 71 contains a mechanical float with a magnet inside. When the probe is submerged, the float rises, and the magnet actuates a switch. The switch closes (makes contact) to indicate the presence of water.

If the water level drops below the probe, the float drops, and the switch opens (breaks contact): The controller will stop the pump. When the water level recovers and the switch closes again, the controller will delay the restart for 15 minutes for the water level to recover. To force a quick restart, turn the controller off, then on again. The switch is sealed, so the contacts never touch the water.

Figure 37: Well probe



Figure 36: Vent and drain holes

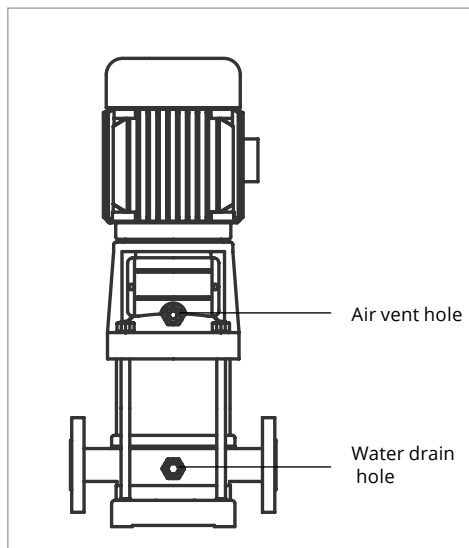

Submersion depth – The maximum submersion depth is 50 meters.

Fixing – Along with the probe two cable ties are provided. For a pump that is to be installed in a vertical position, clamp the probe to the pipe just above the pump outlet, as shown in "Figure 38: Well probe fixing" below. Splice the two wires of the probe using the splice kit components that are packed with the probe. The assembly procedure is the same as the main pump splice.

Wiring to the controller – Connect the Well probe to the terminals as shown on the diagram. For PSk3-7 to PSk3-15 please refer to "Figure 7: Sensor terminal wiring example" on page 30.

Figure 38: Well probe fixing



Potential problems with the well probe in surface water – The probe has a moving float. It is highly resistant to deposits and debris. However, the float can become stuck where algae or water creatures are present in surface water.

Possible solutions are:

- Fix the probe independently of the pump and pipe (clamped to a weight, but not to the drop pipe). This way, it can be pulled out for inspection or cleaning without the need to lift the pump. (This may not be feasible if the well casing is smaller than 6 in)
- Pull the probe out periodically (with the pump, if necessary) for testing and inspection. The pump should stop a few seconds after the probe leaves the water.
- Wrap the probe in a protective screen (fiberglass window screen, for example).
- Use a different type of float switch. You can use any switch that makes contact on rise (normally open). Use an encapsulated switch instead of the well probe if there is enough space for it to operate properly, for example the LORENTZ float switch.

 **CAUTION** – Never let the pump run dry. Dry running will damage the pump and void the warranty. LORENTZ requires a dry run protection for every pump system.

CAUTION – The well probe must be positioned vertically, within 10°. If the pump is not to be installed vertically, find an alternative way to mount or suspend the probe, so that it is located higher than the pump, and in a vertical position.

9.2 Water detection sensor

The water detection sensor protects the surface pump from dry run. It is ONLY installed with surface pumps.

For operation with submersible pumps the water detection input terminals need to be bypassed with a jumper cable. If the jumper is not in place the controller will show "Source Low" and the pump will not run.

 **CAUTION** – For submersible pumps a jumper cable between the terminals 5 and 6 has to be installed.

CAUTION – If the water level of the water source drops below the inlet of the suction pipe the pump will suck in air together with the water.

CAUTION – Air inside the suction pipe can lead to cavitation and/or dry running of the pump.

The water water detection sensor needs to be connected to the water detection input terminals. For PSk3-7 to PSk3-15 please refer to „Figure 7: Sensor terminal wiring example“ on page 30. The wires of the LORENTZ water detection sensor need to be connected to COM and Signal (polarity does not matter).

9.2.1 Water detection sensor installation

This section is for the installation of the LORENTZ water detection sensor only. This guide is not universally applicable for sensors of other suppliers/ manufacturers.

LORENTZ recommends using a water detection sensor to protect the pump against water shortage.

 **WARNING** – Running the pump completely dry will damage the pump within seconds and void the warranty. The purpose of the water detection sensor is to sense the loss of water and turn the pump off before it can run dry.

The sensor has to be installed close to the pump inlet.

If the controller detects dry running it will stop the pump. Following a run dry situation the pipeline must be refilled manually. Check the pipeline for leakage.

The controller will delay the restart after the pipeline has been refilled for 15 minutes.

9.2.2 Steel/Stainless steel pipe

Step 1: Weld the adapter to the inlet pipe ("Figure 40: Adaptor welded on inlet pipeline" on page 75) – The material of the adapter must match the material of the pipe. Both stainless steel and steel adaptors are available from LORENTZ.

Step 2: Connect the sensor housing to the PTFE washer on top of the adapter ("Figure 41: Mounted probe housing" on page 75) – Fasten the sensor housing tightly and make sure that there is no leakage at the PTFE washer. Connect the vent valve to the sensor housing. The thread must be sealed; for example, PTFE tape can be used as sealant.

Step 3: Put the water detection sensor into the sensor housing ("Figure 42: Mounted water detection sensor" on page 75). Make sure there is no leakage.

Step 4: Connect the water detection sensor to the water detection sensor input NC and COM of the PSk3 Controller, see also chapter "7.4.1.5 Pump Accessory Wiring" on page 40. The polarity does not matter.

Step 5: Fill the inlet pipeline, until only water flows out of the vent valve. There must be no air bubbles left in the water. Close the vent valve after venting.

Figure 39: Technical drawing of adaptor (in mm)

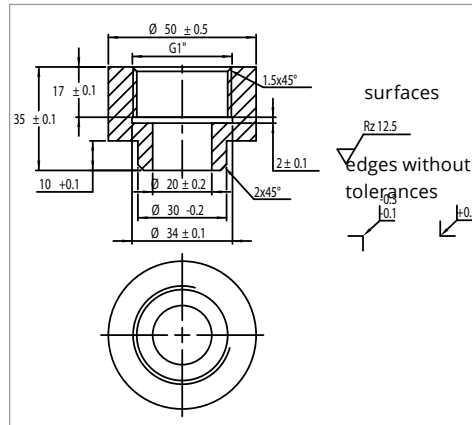

Figure 40: Adaptor welded on inlet pipeline

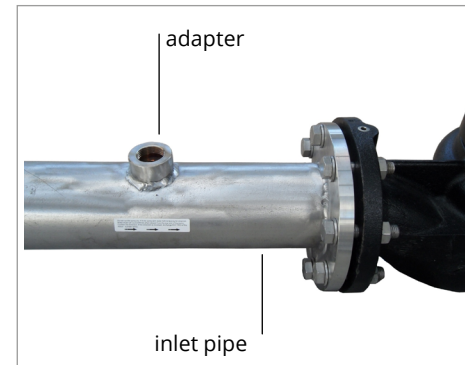

Figure 41: Mounted probe housing

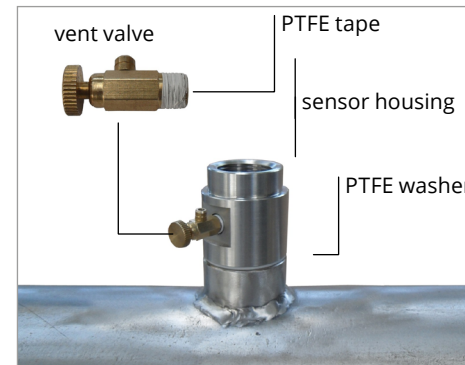
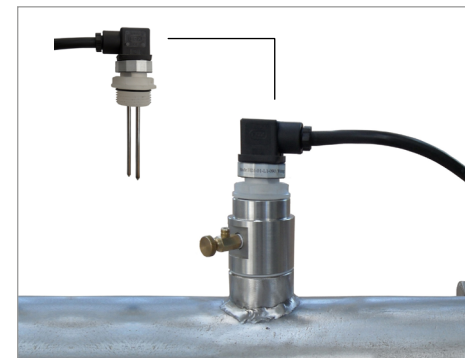

Figure 42: Mounted water detection sensor



NOTE – The electrode sensor must be cleaned regularly to prevent failure caused by scale formation on the two electrodes. Interval time depends on your water quality.

9.2.3 HDPE pipe

Option 1: Weld a tee-piece into the HDPE pipe, see also „Figure 43: HDPE pipe tee-piece“ on page 76. The tee-piece must have a 1" female thread (G1", whitworth pipe thread). The pipe diameter of the fitting should be the same as the pipe size. This piece will be welded into the pipeline.

The tee-piece described above is **not** delivered by LORENTZ.

Option 2: Install an additional piece of steel or stainless steel pipe with flanges on both sides of the HDPE inlet pipeline, see also „Figure 44: Steel flange with adaptor in HDPE pipe“ on page 76. Weld the steel/stainless steel adaptor for the water sensor on the steel/stainless steel pipe according to chapter "9.2.2 Steel/Stainless steel pipe" on page 74.

The steel / stainless steel pipe is **not** delivered by LORENTZ.

After completion of option 1 or option 2, continue with step no. 2. of chapter "Pipe system – We advise that pipe expansion joints are used close to the pump on both inlet and outlet to reduce noise and vibration (see also „Figure 35: Pipe expansion joints“ on page 68). It is recommended that you install a gate valve in the suction and discharge pipeline close to the pump to avoid draining of the pipe while cleaning (e.g. filters), repairing, servicing or replacing the pump system.

Figure 43: HDPE pipe tee-piece

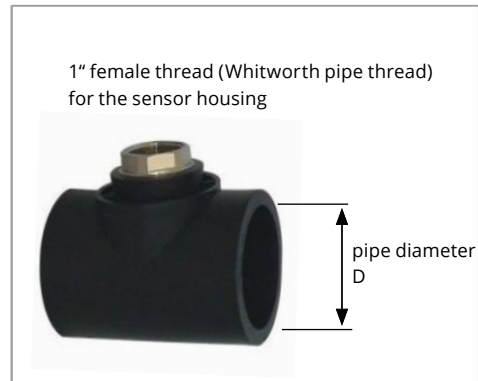
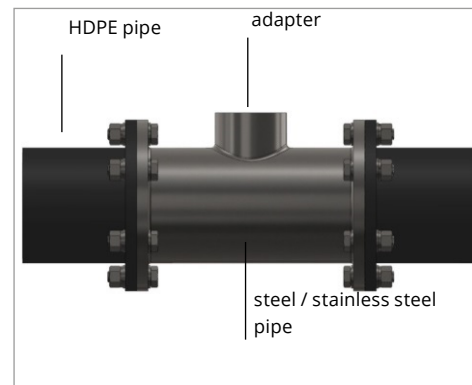

Figure 44: Steel flange with adaptor in HDPE pipe



9.3 Water meter installation

For information on the water meter installation, please refer to the manual of the manufacturer. Pay attention to the installation position, flow direction and the calming section.

Basic rule: The water meter should have 10 nominal diameters straight pipe ahead of the meter and 5 nominal straight pipe diameters after to ensure proper flow through the meter.

Figure 45: Water meter installation

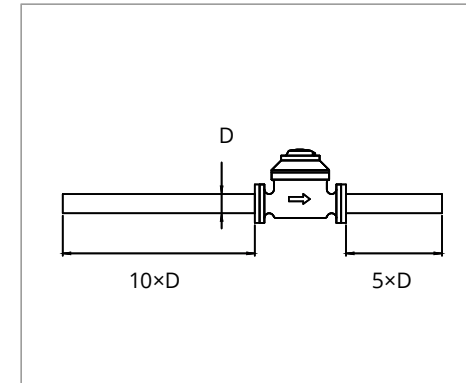

Figure 46: LORENTZ water meter



9.4 Level sensor installation

The LORENTZ range of liquid level sensors use pressure to measure the level of water in a well or tank. The sensors can be used for long term water level monitoring and also for pump control in applications where a well probe cannot be used.

The Level sensor is connected to one of the two Analog Inputs of the controller. Configuration of the sensor is done with LORENTZ Assistant.

For further information about the level sensor please refer to the COMPASS datasheet.

Figure 47: LORENTZ Liquid Level Sensor



9.5 Water Level Management Solution (WLMS) installation

The LORENTZ Water Level Measurement Solution (WLMS) accurately measures water levels in boreholes and tanks. WLMS is a combination of pressure sensor and plug-in barometer to provide water level measurement for PS2 and PSk3 systems. Used in conjunction with inbuilt software WLMS allows you to record and monitor water levels in your tank and control your system based on these levels.

For further information about the level sensor please refer to the COMPASS datasheet and the WLMS manual for installation and operation.

Figure 48: Water Level Measurement Solution



For more information about the pressure sensor range (LPS) please refer to the COMPASS datasheet. Ensure that the pressure sensor is suitable for your application regarding pressure range and temperature resistance.

LORENTZ PSk3 CS-F pump ends allow the installation of the pressure sensor at the pump housing. This is a simple alternative compared to the conventional pipeline installation.

- For the pump types **LORENTZ PSk3 CS-F1 to CS-F20** it is necessary to remove the vent plug to install the pressure sensor. Therefore install the pressure sensor after the pump is filled with water, see chapter "8.3.5 Initial Start-up" on page 69.
- All other **LORENTZ PSk3 CS-F** pump types have a second filler plug which can be replaced by a pressure sensor.

CAUTION - The connection thread size at the pump housing of the CS-F pumps is G1/2". The connection thread size at the pump housing of the CS-G pumps is G1/4".

CS-G pump ends allow the installation of the pressure sensor at the flanges of the suction and pressure side.

9.6 Pressure sensor installation

The LORENTZ range of liquid pressure sensors are used to measure the pressure in a pipe. The sensors are commonly used to measure the pressure at a well head or feeding into irrigation systems. The liquid pressure sensor can also be used in constant pressure applications and as a pressure switch. Please refer to partnerNET for more information.

Figure 49: Pressure sensor installation



9.7 Float Switch (Full Tank Shut-off)

We recommend the use of a float switch or other means to prevent overflow of your tank. This will stop the pump when the tank is full, then reset when the level drops. This conserves ground water, prevents overflow, and eliminates unnecessary pump wear. PSk3 controllers allow the use of a small signal cable to a remote float switch, even if the tank is a long distance away.

Float switch requirements:

We recommend installing a surge protector to avoid possible surges (e.g. from lightning) from the float switch cable into the controller.

- A switch must be used, not wet electrodes.
- The preferred system requires a float switch to OPEN contact on rise to turn the pump OFF. This is called "normally closed" (N.C.).

Float switch cable requirements:

- Two wires are needed.
- Minimum wire size 1 mm² / AWG 18. This is good for a distance as far as 600 m / 2,000 ft.
- The cable must be suitable for its environment.
- If it must run a long distance, use twisted-pair shielded cable to reduce the chance of damage from lightning-induced surge.

Grounding shielded float switch cable - If you use shielded cable, connect the shield to ground at the controller only. Do not ground the shield at the float switch. This will reduce surges induced by nearby lightning.

Operation of the float switch system - When the water level is high, the float switch will stop the pump. The TANK-FULL indicator on the controller will light up. When the water level drops, the float switch will signal this to the controller. The indicator light will turn off, and the pump will restart if sufficient power is available.

Figure 51: Float switch scheme

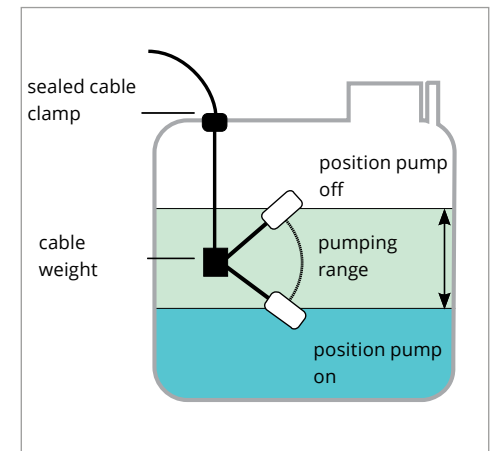

Figure 50: Float switch



Wiring to the controller – The float switch will be connected to the remote switch input. For PSK3-7 to PSK3-15 refer to "Figure 7: Sensor terminal wiring example" en la página 30.

Manual remote control switch – The float switch circuit can be used with a manual switch to turn the pump on and off from a distance. Use any simple on/off switch available from an electronic supply, electrical supply, or hardware store (it only carries low voltage, very low current).

9.8 Sacrificial Anode

The LORENTZ Sacrificial Anode is designed for use with LORENTZ pump ends. Where solar pump ends operate in aggressive water conditions acidic water can attack the passive layer of the high quality-steel pump end. This corrosion reduces the life-time of the product. The LORENTZ Sacrificial Anode contributes to the protection of the pump system from this type of corrosion and extends the pumps life.

For further information about the Sacrificial Anode please refer to the COMPASS datasheet.

9.9 PV Disconnect 1000-40-5

The LORENTZ PV Disconnect is a PV connection box with an integrated disconnect switch. The box is designed to connect up to five PV module strings with the pump controller by using the terminal clamps located inside the box. The DC-rated disconnect switch is used as a manual circuit breaker between the solar array and the load. This switch is easily accessible by opening the hinged lid at the bottom spring lock.

The use of a properly sized DC disconnect switch is an important safety measure and obligatory for a professional installation of a solar pumping system. The switch must be installed between the solar generator and the pump controller. It must meet the electrical requirements of the connected devices. The PV Disconnect has been designed to cover the range of PSK3 pump systems.

For more information on installing, wiring and technical specifications please refer to the PV Disconnect manual.

Figure 53: PV Combiner 1000-125-4



Figure 54: PV Disconnect 1000-40-5

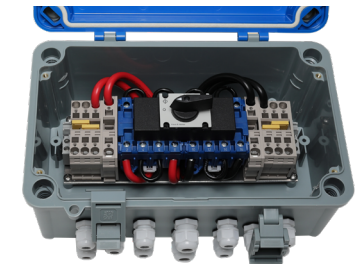
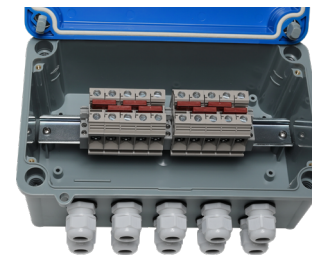
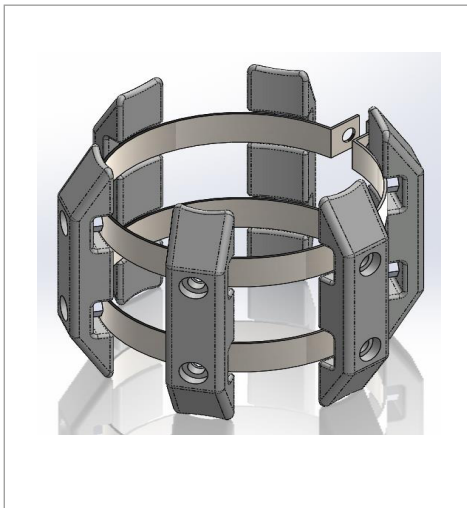

Figure 52: Sacrificial anode for submersible pump ends



9.10 PV Combiner 1000-125-4 for PSk3-7 to PSK3-15

The LORENTZ PV Combiner is a PV connection box to be used with PSk3 pump systems. The box is designed to combine up to 4 DC input strings in parallel coming from multiple "PV Disconnect-1000-40-5" and connect them to the pump controller.

The use of a properly sized DC disconnect switch is an important safety measure and obligatory for a professional installation of a solar pumping system.



CAUTION – Never use this product as a replacement for the PV Disconnect 1000-40-5!

For more information on installing, wiring and technical specifications refer to the PV Combiner manual.

9.11 PV Protect 1000-125 for PSk3-7 to PSK3-15

The LORENTZ PV Protect is a surge protective device (SPD) to be used with PSk pump systems. It is installed on the DC input line close to the pump controller.

The PV Protect provides an enhanced level of protection from electrical surges (e.g. indirect lightning strikes). For effective operation it requires a reliable ground connection.

The use of a properly sized DC disconnect switch is an important safety measure and obligatory for a professional installation of a solar pumping system.



CAUTION – Never use this product without a PV Disconnect 1000-40-5!

For more information on installing, wiring and technical specifications please refer to the PV Protect manual.

9.12 SmartStart

9.12.1 Product description

Table 15: SmartStart packing list

#	Item	QTY
1	SmartStart	1 unit
2	Fuse	1 unit
3	Cable	1 unit

The SmartStart allows a generator with auto-start to be controlled by the PSk3 system.

The SmartStart is connected to the PSk3 controller via a supplied made-up cable. The cable provides power and signalling between the PSk3 and SmartStart.

Depending on how you configure the PSk3 the system will switch the generator on and off.

Inside the SmartStart housing is a space for an NP7-12 battery. The battery is charged by the PSk3 during normal solar or grid operation. The battery provides power to the PSk3 logic boards to allow control of the system even during nighttime or when a generator is switched off. An example of why the battery is required would be for a 02:00 (2am) start of pumping.

9.12.2 Generator compatibility

In order to use this feature the generator must have a two wire autostart function, the SmartStart provides a potential-free switching contact that is closed when the generator requirement is triggered.

The maximum switching capability for the relay contact is 250 V AC / 30 V DC, 2A.

Refer to your generator supplier for more information on autostart.

Figure 55: PV Protect 1000-125-4

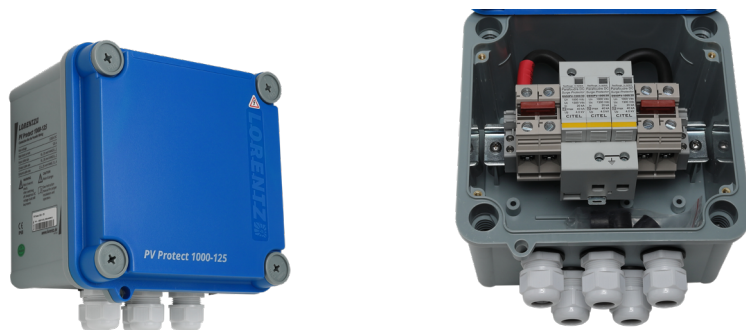

9.12.3 Physical installation

The SmartStart must be mounted within 1 m of the PSk3 controller. The provided SmartStart to PSk3 cable will define a logical mounting position.

Bottom access is required to the SmartStart for the connection of cables. The battery and connections are accessible from the front after removing the screwed lid. You must allow a space above and below the SmartStart of 250 mm.

9.12.4 Cable entries and external sockets

There are cable glands and plug sockets in the bottom of the SmartStart. The socket for the remote PSk3 connection is pre-wired and pre-assembled in the SmartStart housing. Cables for the generator connection and the auxiliary connection which leads through the cable glands have to be fixed tightly in the glands for strain relief and sealing.

9.12.5 Wiring

The SmartStart to PSk3 cable is prewired and connected.

The generator auto start connections are made using the remote switch plug inside the SmartStart. These terminals are marked NO and Com ("Figure 56: Opened SmartStart" on page 85). The connector type is a spring connection, press the white button with a small screwdriver and then insert the stripped cable. 5 - 6 mm of bare conductor is required for a good connection.

The maximum switching capability for the remote switch is: 250 V AC / 30 V DC, 2 A.

9.12.6 Battery installation

The SmartStart is powered by a battery. The battery is charged by the controller through the supplied custom cable. The required battery must be ordered separately.

If the battery is not delivered by LORENTZ, it must meet the following characteristics:

- Genesis NP7-12 or similar. Sealed 12V AGM lead acid battery
- Min. capacity: 7Ah
- Max. dimensions without connector: 151 x 70 x 95 mm (5.94 x 2.56 x 3.74 in)
- height overall max. 100 mm (3.94 in)
- Connector: 4.8 mm (0.189 in) faston tabs

It is possible to purchase a battery from LORENTZ. Contact your distributor for further information.

If a SmartStart is delivered by LORENTZ with batteries included, they must be recharged every 6 months during storage.

Figure 56: Opened SmartStart

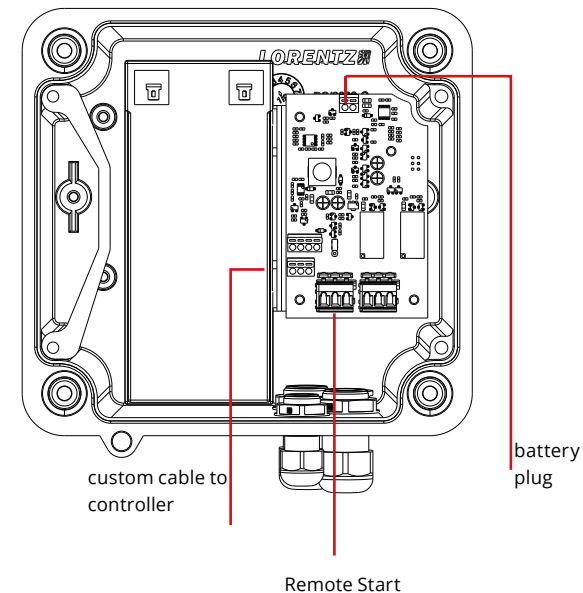

EN Wiring

The wiring must be done by qualified staff only. In the kit there is a green 2-pin plug with two pre-assembled cables (black and red). The 2-pin plug must be removed from the board before wiring. The corresponding socket on the right upper edge of the board is labeled with the correct cable configuration. ("Figure 56: Opened SmartStart" on page 85)

Battery

Use the 2-pin plug ("Figure 56: Opened SmartStart" on page 85) with the pre-assembled cables. The red cable is for plus (+), the black cable is for minus (-).

Make sure the cables are securely mounted to the battery. Ensure and check the correct polarity.

Remove the battery fixing. Slide in the battery. Ensure the battery is correctly seated and secure it with the battery fixing.

9.12.7 LED status

A **flashing red** LED indicates that the battery voltage is low.

A **permanent green** LED indicates that the power of the PSk3 is on and that the PSk3 controller is charging the SmartStart.

A **flashing green** LED indicates that the SmartStart supplies the PSk3 controller with power.

A **permanent yellow** LED indicates that the generator relay is switched on.

10 Operating the Pump

This graphic displays the front LED indicators of the PSk3 controller. For a detailed description of the LED status indication please refer to "10.1 LED Status" on page 88.

The on/off switch is located at the bottom of the controller.

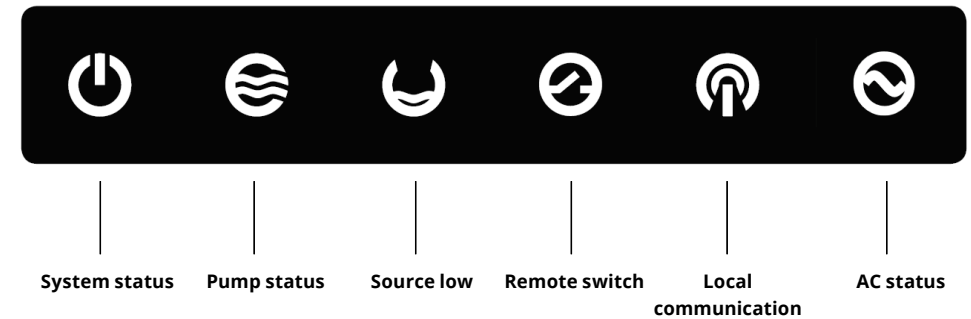





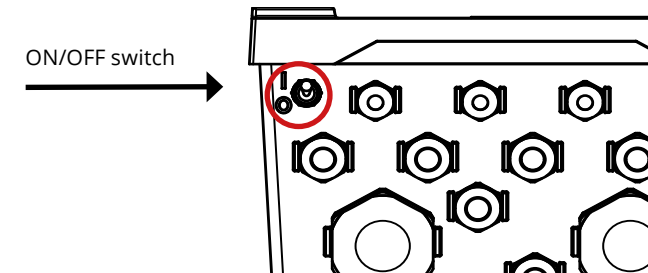

POWER SWITCH (ON/OFF)

 **WARNING** - The switch only switches pump operation ON/OFF. It is not a disconnect switch.

When switched OFF/ON during operation, it resets the system.



10.1 LED Status

	System status indicator	green light	Power is present, ON/OFF switch is in ON position
		green light flashing	Pump in standby mode due to settings ON or OFF switch in OFF position
		no light	Insufficient power input
	Pump status indicator	green light	Pump is on
		green light flashing	Pump is ON, number of flashes indicates pump speed
		red light	Pump stopped, check with LORENTZ Assistant app
		red light flashing	Flashing indicates overtemperature of the controller
	Source low indicator	red light	Well probe, water sensor or LLS (Liquid level sensor) has detected a low water source
		red light flashing	Flashing indicates "source low" incident since the controller was switched ON
		no light	Water source is okay
	Remote switch indicator	red light	Remote switch or LPS pressure switch feature triggered, pump stopped
		no light	Remote switch not triggered
	Local communication	blue light	Bluetooth® connection active
		blue light flashing	Stored data is being pulled to the LORENTZ Assistant app
		no light	Currently no Bluetooth® communication
	AC Status indicator	green light	AC power is present and used to run the pump
		green light flashing	AC power is present but not used
		no light	AC power not connected

Status description

- **System (green)** – The controller is switched on and power is available. In low-power conditions, the light may show even if there is not enough power to run the pump. Flashing indicates the pump is not running due to settings, e.g. a timer set up with LORENTZ Assistant.
- **Pump (green)** – Pump is running. The sequence of flashing indicates pump speed (RPM). RPM can be read by the flashing sequence of the Pump ON LED:

LED signal	Motor frequency [Hz]
LED On	> 0
1 flash	> 25
2 flashes	> 30
3 flashes	> 35
4 flashes	> 40
5 flashes	> 45

- **Pump (red)** – An error has occurred, please check with LORENTZ Assistant app for details. Flashing indicates that the controller's thermal protection was triggered due to a too high temperature. The controller has reduced the motor speed or stopped the pump. It will automatically speed up or restart after cooling down.
- **Source low (red)** – The water source has dropped below the level of the low-water probe or the water sensor has detected air in the suction pipe. After the water level recovers or the suction pipe has been re-filled with water, the pump will restart after a delay. Please refer to „10.3 Time delays“ on page 90. Flashing indicates that the controller has stopped due to a "SOURCE LOW" incident detected earlier. The number of flashes indicates the number of incidents (up to three). Toggle the ON/OFF switch to reset this indicator. If control by level features are used in conjunction with a liquid level sensor settings this will also be indicated by the source low LED. Please refer to LORENTZ Assistant app.
- **AC status (green)** – Indicates that AC power is connected and currently used to run the pump. If the light is flashing, then AC power is present but currently not used to run the pump (solar-direct only).
- **Remote switch (red)** – A pump shutdown was triggered by the remote switch wired to terminals 3 and 4 or by control by pressure settings in conjunction with a liquid pressure sensor. Please refer to LORENTZ Assistant app.

10.2 Starting the pump

- (1) Make sure that an unhindered water flow is possible and not blocked, e.g. by closed valves.
- (2) Switch on the PV generator disconnect switch.
- (3) Toggle the power switch on the controller to ON. A solar-direct pump will now start when sufficient irradiation levels are reached and neither the well probe, remote switch or LORENTZ Assistant setting prevents the controller from starting the pump.

10.3 Time delays

Event	Time delay
Pump stops due to insufficient irradiation	4 minutes
Full-tank float switch resets	2 - 3 seconds
Low water well probe regains contact with water	15 minutes
Shutdown due to overtemperature	Automatic restart after cooling down
low input power incident	4 minutes

To force a quick start, the above listed delays can be bypassed by switching the POWER switch OFF/ ON. The pump should now start immediately if sufficient power is present.

10.4 Parameter settings



NOTE - Please always refer to the LORENTZ Assistant documentation available on partnerNET for the latest developments.

The parameter settings for the PSk3 controller are configured via our Android™ LORENTZ Assistant app. Search the Google Play Store for "LORENTZ Assistant".

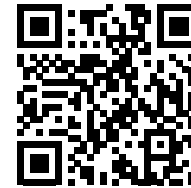

Detailed instructions on how to use the app and what configurations have to be made are can be found in the app itself and also on LORENTZ partnerNET.



WARNING - A missing or wrong configuration can result in pump damage.

11 LORENTZ CONNECTED

The LORENTZ CONNECTED portfolio ensures that technicians and customers have the information they need to manage their water system. LORENTZ CONNECTED offers a range of features for configuring, monitoring and managing LORENTZ products.

For local configuration, management and monitoring this is done via Bluetooth® connection from the PSk3 controller to LORENTZ Assistant app running on an Android™ device such as a smartphone or tablet.

For remote management and monitoring PSk3 can be connected to LORENTZ cloud based monitoring and management platform – LORENTZ Global. A PS Commander is installed as a gateway to communicate via Bluetooth® with the PSk3 controller and the cloud based LORENTZ Global application servers. Viewing of data and configuration of the PSk3 system is available from any web browser anywhere in the world.

11.1 PSk3 data access and data logging

In addition to using operational and sensor data for pump control, the PSk3 controller also stores data for analysis and performance reporting. Operating data and key performance data is stored in the PSk3 controller and is accessed by using the LORENTZ Assistant app. Both real time data (Actual Data) and Stored data are available from the controller via Bluetooth® connection to the LORENTZ Assistant app. This connection is available within Bluetooth® range of the PSk3 controller, typically within 10 metres (30 feet)

11.2 LORENTZ Assistant

LORENTZ Assistant app runs on the Android™ operating system which is found in many smart phones and tablets.

LORENTZ Assistant app can be used by installers, technicians or customers to view system data, look at pump performance and change configurations. The app is free to use and has different profiles available to ensure only qualified users are able to access certain functions.

LORENTZ Assistant app is available on the Google Play Store.

Figure 57: LORENTZ Assistant Android™ App

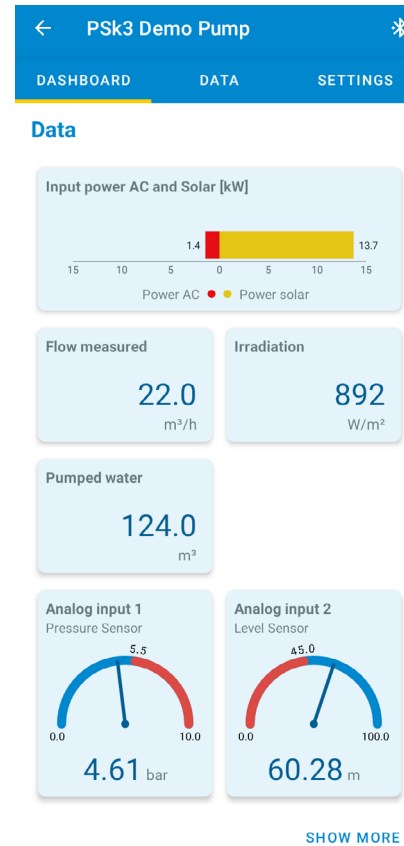
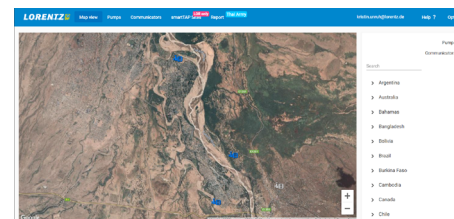

Figure 58: LORENTZ Global view of installation site



11.3 LORENTZ Global & PS Commander

For remote monitoring and management, LORENTZ offer a cloud based platform for PSk3 and other LORENTZ products. This is designed to work effectively and economically for customers managing one device to customers managing thousands of devices.

A PS Commander is installed close to the PSk3 system. The Commander acts as a cellular gateway to send data from the PSk3 to the LORENTZ Global secure platform. Settings changes and configurations can also be sent from LORENTZ Global to the PSk3 system.

Each user can configure alerts so that LORENTZ Global pro-actively informs them of any events on the PSk3 system. Users can log on at anytime via a web browser to see all of their LORENTZ pump systems in an intuitive management interface.

LORENTZ Global provides proactive monitoring and full management of your systems anywhere in the world.

The LORENTZ Global service is a pay per month per managed device service that includes unlimited platform licensing and all cellular and data costs

You can login to LORENTZ Global at <https://global.lorentz.de> using your standard partnerNET credentials or try the demo account that is available.

Figure 59: LORENTZ Global view of system details

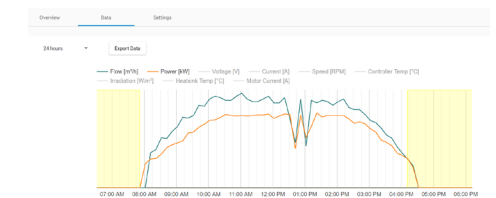

12 Troubleshooting

Please read this section carefully in case you experience any problems with the pump system and follow the checklists. Should technical support by LORENTZ become necessary, please provide the model and serial numbers. You can easily receive help from our technical support team through the ticket system on our partnerNET platform.

12.1 Pump does not run

Most problems are caused by either wrong **cable connections** (in a new installation) or failed connections, especially insufficiently tightened cables that come loose from the terminal. Please check the wiring. The System ON light will indicate that the system is switched on and connected to the controller. It indicates that voltage is present but in a solar-direct system there may not be sufficient power to start the pump. In this case it will attempt a restart every 240 seconds.

When the **solar power on the array is too weak** for the pump to run, it will attempt to start about every 240 seconds. During each attempt, you will see the PUMP ON light come on.

If a **shadow** suddenly passes over the array, e.g. if you walk in front of it, the controller might lose track of the input voltage. It may make rapid on/off noises and a high-pitched noise, then stop. This does not indicate a problem. The pump will attempt to restart after the normal delay.

Time delays

- (1) After the pump stopped due to insufficient sunshine – 4 minutes
- (2) After full-tank float switch resets – 2 to 3 seconds
- (3) After low-water probe regains contact with water in the source – 15 minutes, but the indicator light will slowly flash for the rest of the solar day, or until power is disrupted or the controller is turned off/on

Force a quick start – To test or observe the system, you can bypass the normal time delays. Switch the POWER switch off then on again. The pump should start immediately if there is sufficient power.

12.2 Pump attempts a restart every 4 minutes

The controller will emit a low noise as it tries to start the pump. The pump will start to turn or only vibrate a little.

- (1) There may be insufficient power reaching the controller. A solar-direct system should start if there is sufficient sun to cast a slight shadow.
- (2) If the pump was recently connected (or reconnected) to the controller, it may be running in reverse direction due to a wiring error.
- (3) If the motor shaft only vibrates but does not turn, it may have power on only two of the three motor wires. This will happen if there is a broken connection or if you accidentally interchanged one of the power wires with the ground wire.
- (4) The pump or pipe may be blocked by mud, clay, sand or debris.



CAUTION – If the pump is blocked, it has to be cleaned. Repeated starting of a blocked pump may cause damage to the motor. This will void the warranty.

Check the PV generator

Make sure the PV generator is facing the sun and there is no partial shading of the array. A partial shading of as little as 10% of the arrays' surface can stop the pump.

Check all wires and connections

Carefully check for improper wiring (especially in a new installation) and wiring condition. Wires are often damaged by animals if they are not enclosed in conduit (pipe). Pull on wires slightly to check for failed connections.

Check the controller

- (1) Check all cable connections for any loose cables.
- (2) Check for a burnt smell. This will indicate a failure of the electronics. Look for burnt wires, bits of black debris, and any other signs of lightning damage.
- (3) Inspect the grounding wires and connections. Most controller failures are caused by an induced surge from nearby lightning where the system is not effectively grounded. Ground connections must be properly made and free of corrosion.

Check the dry running protection

If the controller indicates "Source low" when the pump is submerged in water or draws from a sufficient water source, check the dry running protection system. The probe is mounted on, or near the pump. If inspection is not feasible, you can bypass the probe or test it electrically.

Check the float switch

If the controller indicates "Remote OFF" when the storage tank is not full, inspect the float switch system. If your system has a float switch, it will be mounted in the tank. If inspection is not feasible, you can bypass the switch or test it electrically.

Force a quick start

If you restore a connection or bypass the probe or float switch, there is no need to wait for the normal time delay. Manually switch the on/off switch (or the power source) off and on to reset the system. The pump should start immediately if sufficient power is present.

If the pump responds to the bypass tests but not to the float switch, the wires may be shorted (touching each other) or open (broken) or the switch may be stuck with debris, or out of its correct position.

Quick checklist

Make sure

- (1) the pump is suited for the total lift that is required.
- (2) there no speed limitation set in LORENTZ Assistant. Connect with LORENTZ Assistant to confirm correct settings.
- (3) the solar array is receiving sufficient sun light without shading on the modules, the PV generator is oriented properly and tilted at the correct angle. Inspect and test the PV generator circuit and the controller output, as stated. Take notes of your measurements.
- (4) all wires and pipe runs are sized adequately for the respective distance.
- (5) there is no leak in the output pipe from the pump.

Could the issue not be resolved, please raise a service case (ticket) in LORENTZ partnerNET including the service support forms available on partnerNET, model and serial numbers and your measurements.

13 Service and Maintenance

WARNING – If an AC power source is connected to the controller use the circuit breaker to disconnect the AC power from the controller.

If a DC power source (PV Generator) is connected to the controller use the disconnect switch(es) to disconnect the DC power from the controller.

Wait at least 5 minutes before doing any service and maintenance on the system.

Use a multimeter to verify that there are no residual AC or DC voltages present.

Main points for inspection and maintenance

The surface pump motors need to be re-lubricated every 5000 h of running time as indicated by the label on the motor.

The cooling fan and heat sink can collect dust and particles over time. They should be inspected and cleaned regularly, at least once a year. Use a soft brush or cloth for cleaning. Be careful with using compressed air as it can spin-up the fan uncontrollably and cause damage to the fan or controller.

Please use the controller under the environmental conditions of this manual. Inspect and maintain as per "Table 16: Inspection overview" on page 98.

Routine inspection and maintenance

To extend lifetime of the controller a regular inspection is advised. We recommend an inspection interval of at least once a year.

Requirement of inspection and maintenance:

- (1) The inspection must be performed by professional technical personnel.
- (2) Cut off the power supply of the controller first.
- (3) Avoid leaving any metal components in the controller, or else they might cause damage to the equipment.
- (4) Do not use a megohmmeter to test the control circuit.
- (5) When conducting any insulation test on the motor, you must dismantle the connection between motor and controller.

EN

Please make sure that the inspected items (first column) meet the judgment standards (third column).

Table 16: Inspection overview

Inspection item	Inspection content	Judgment standard
running environment	1. temperature, humidity 2. dust, gas	1. temperature < 50 °C 2. humidity < 80 %, no dew condensation, no peculiar smell, flammable, explosive gas
cooling system	1. installation environment 2. radiator 3. cooling fan	1. excellent ventilation in installation environment 2. radiator air duct not blocked 3. fan not dirty or blocked
controller body	1. vibration, temperature rise 2. noise 3. lead, terminal	1. stable vibration, normal temperature of the shell 2. no abnormal noise and peculiar smell 3. fastening screws not loose
motor	1. vibration, temperature rise 2. noise	1. steady running and normal temperature 2. no abnormal and uneven noise
input and output parameter	1. input voltage 2. output current	1. input voltage in the specified scope 2. output current under the rated value



Declaration of Conformity

We,

BERNT LORENTZ GMBH
Siebenstuecken 24
24558 Henstedt-Ulzburg
Germany

declare under our sole responsibility that the products

PSk3 Controller of series:

PSk3-7, PSk3-15,

to which the declaration relates, are in conformity with the Council Directives on the approximation of the laws of the EC Member States relating to:

- Electromagnetic Compatibility (2014/30/EU)
- Low Voltage Directive (2014/35/EU)

References of harmonized standards and/or other technical specifications applied:

EN 61800-3:2004+A1:2012 EN 61800-5-1:2007

LORENTZ
BERNT LORENTZ GmbH & Co. KG
Siebenstuecken 24, 24558 Henstedt-Ulzburg
Germany, Tel. +49 (0) 4193 8806-700, Fax -708

Bernt Lorentz, CEO

Person authorized to compile the technical file and empowered to sign the EC/EU declaration of conformity.

Henstedt-Ulzburg, Germany, 1st March 2021

EN