

Installation and use manual

MIDA



Index

1. MIDA Introduction	3
2. Safety Instructions.....	3
3. Technical Characteristics	4
3.1 Performance	4
3.2 Weight and dimensions	4
3.3 Cable entries	4
4. MIDA installation	5
4.1 Mechanical installation	5
4.2 MIDA Installation for constant pressure control	7
4.2.1 Pressure tank	7
4.2.2 Pressure sensor	7
4.3 MIDA installation for differential constant pressure applications	8
4.3.1 Sensors wiring	8
4.3.2 Programming.....	8
5. Electric wiring.....	9
5.1 Protections	13
5.2 Electromagnetic compliance.....	13
5.3 Installation with long motor cables	13
6. MIDA use and programming.....	14
6.1 Monitoring and programming.....	15
6.1.1 Monitoring	15
6.1.2 Programming.....	16
6.1.3 FOC motor control	24
6.2 COMBO operation.....	26
7. Protections and alarms.....	27

1. MIDA Introduction

MIDA is a variable frequency drive (inverter) designed to control and protect pumping systems by varying the output frequency to the pump.

MIDA can be applied to both new and existing pumping systems providing:

- energy and cost savings
- simplified installation and an overall lower pumping system cost
- longer life of the pumping system and relevant components
- improved reliability

MIDA, when connected to any pump, manages the system operation to maintain a certain constant physical quantity (pressure, differential pressure, flow, temperature, etc.) regardless of water demand. The pump is operated only when needed thus avoiding unnecessary energy consumption.

MIDA at the same time is able to:

- protect the motor from overload and dry running
- implement soft start and soft stop to increase the system life and reduce current peaks
- provide an indication of current consumption, voltage, and power
- maintain a record of run time and display any errors and/or failures reported by the system
- connect to other MIDA units for combined operation

MIDA can be installed on motor terminal box or fixed on the wall.

In the last case, through the use of output filters it is possible to reduce dangerous surges that are induced in long cables, making MIDA suitable for control also of submersible pumps.

2. Safety Instructions

The manufacturer strongly suggests carefully reading this operation manual before using and installing its products. Any operation (installation, maintenance and repair) must be carried out by trained, skilled, and qualified personnel. Failure to observe and follow the instructions in this manual may result in dangerous and potentially lethal electric shock. Pay attention to all standard safety and accident prevention regulations.

	<p>The device must be connected to main power supply via a switch to ensure the complete disconnection from the network before any operation on the MIDA itself (including visual inspection) and/or on the connected load.</p> <p>Disconnect MIDA from the main power supply before commencing any work.</p> <p>Do not open the device without having first disconnected the device from the main power supply and having waited at least 5 minutes.</p> <p>MIDA and pumping system must be grounded properly before operation.</p> <p>For the entire period MIDA is powered, high voltage could be present on the output terminals of the inverter whether or not the pump is running.</p> <p>Tightening all screws on the cover with washers is recommended before powering the device.</p> <p>Otherwise, there may be a failure to connect the cover to ground, creating the risk of electric shock or even death.</p>

Avoid any shock or significant impact during transport.

Check the MIDA immediately upon delivery and check for damage and/or missing parts. If either occurs, immediately notify the supplier.

Damages due to transport, incorrect installation, or improper use of the device will null and void the warranty.

Tampering or disassembly of any component will automatically void the warranty.

The manufacturer cannot be held responsible for any damages to people and/or property due to improper use of its products.

	<p>Devices marked with this symbol cannot be disposed of in household waste but must be disposed of at appropriate waste drop-off centres. It is recommended to contact the Waste Electrical and Electronic Equipment drop-off centres (WEEE) in the area. If not disposed of properly, the product can have potential harmful effects on the environment and on human health due to certain substances present within. Illegal or incorrect disposal of the product is subject to serious administrative and/or criminal penalties.</p>
--	---

3. Technical Characteristics

3.1 Performance

Model	V in +/- 15% [VAC]	Max V out [VAC]	I in [A]	Max I out [A]	Typical motor P2 [kW]	Size
MIDA 203	1 x 230	3 x Vin	4,5	3	0,55	1
MIDA 205	1 x 230	3 x Vin	7,5	5	1,1	1
MIDA 207	1 x 230	3 x Vin	11	7,5	1,5	1
MIDA 304	3 x 230	3 x Vin	3,7	4	0,75	1
MIDA 306	3 x 230	3 x Vin	5,4	6	1,1	1
MIDA 309	3 x 230	3 x Vin	8	9	2,2	1
MIDA 404	3 x 380 - 460	3 x Vin	3,7	4	1,1	1
MIDA 406	3 x 380 - 460	3 x Vin	5,4	6	2,2	1
MIDA 409	3 x 380 - 460	3 x Vin	8	9	4	1

- P.F. line side: 1 (for MIDA 2XX)
- Power frequency: 50 - 60 Hz (+/- 2%)
- Stocking temperature: -30 to 70 °C (-22 to 158 °F)
- Min. ambient temperature at rated current: -10 °C (-14 °F)
- Max. ambient temperature at rated current: 40°C (104 °F)
- Max. altitude at rated current: 1000 m
- Max relative humidity: 95% without condensation
- Grade of protection: IP55 (NEMA 4) or motor IP when connected to motor terminal box *
- Connectivity: Serial RS 485 for COMBO operation (up to 8 units) + Bluetooth SMART for monitoring and programming + Modbus RTU.

* Protect the device from direct exposure to sunlight and atmospheric agents

3.2 Weight and dimensions

Model	Weight *	Size
	[Kg]	
MIDA 203	2,5	1
MIDA 205	2,5	1
MIDA 207	2,5	1
MIDA 304	2,5	1
MIDA 306	2,5	1
MIDA 309	2,5	1
MIDA 404	2,5	1
MIDA 406	2,5	1
MIDA 409	2,5	1

* Weight without packing.

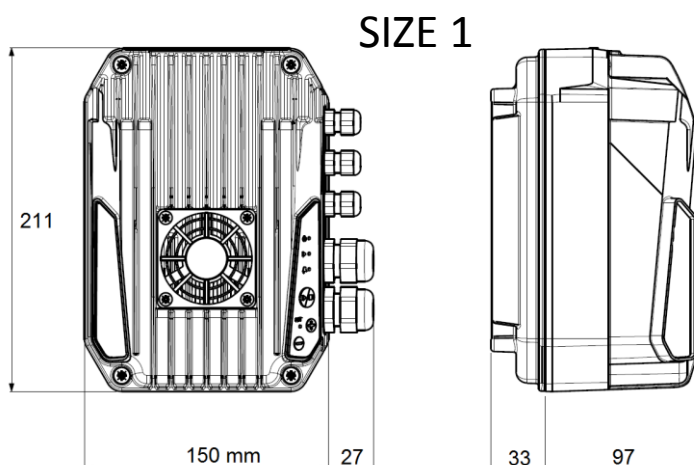

3.3 Cable entries

Model	M20 cable gland	M12 cable gland	EMC clips
MIDA SIZE 1	2	3	3

When MIDA is coupled on motor terminal box, install the cap instead of motor cable gland.

When MIDA is fixed on the wall, install the motor M20 cable gland. Use the EMC clips to connect the screen of sensors cables to the ground earth.

4. MIDA installation

4.1 Mechanical installation

MIDA on motor

MIDA can be installed directly on motor terminal box in horizontal or vertical position.

Check with motor manufacturer if it can be operated by inverter and verify the compatibility of MIDA base with motor terminal box (see drawing).

The rubber gasket on MIDA base grants the sealing between MIDA and motor case.

Pierce the rubber gasket only in correspondence of the 4 threaded holes on motor case.

If possible use the same screws and washers which fixed the terminal box on motor case.

See below instruction how to mount MIDA on motor.

WARNING: after installation check ground earth continuity between motor case and MIDA.

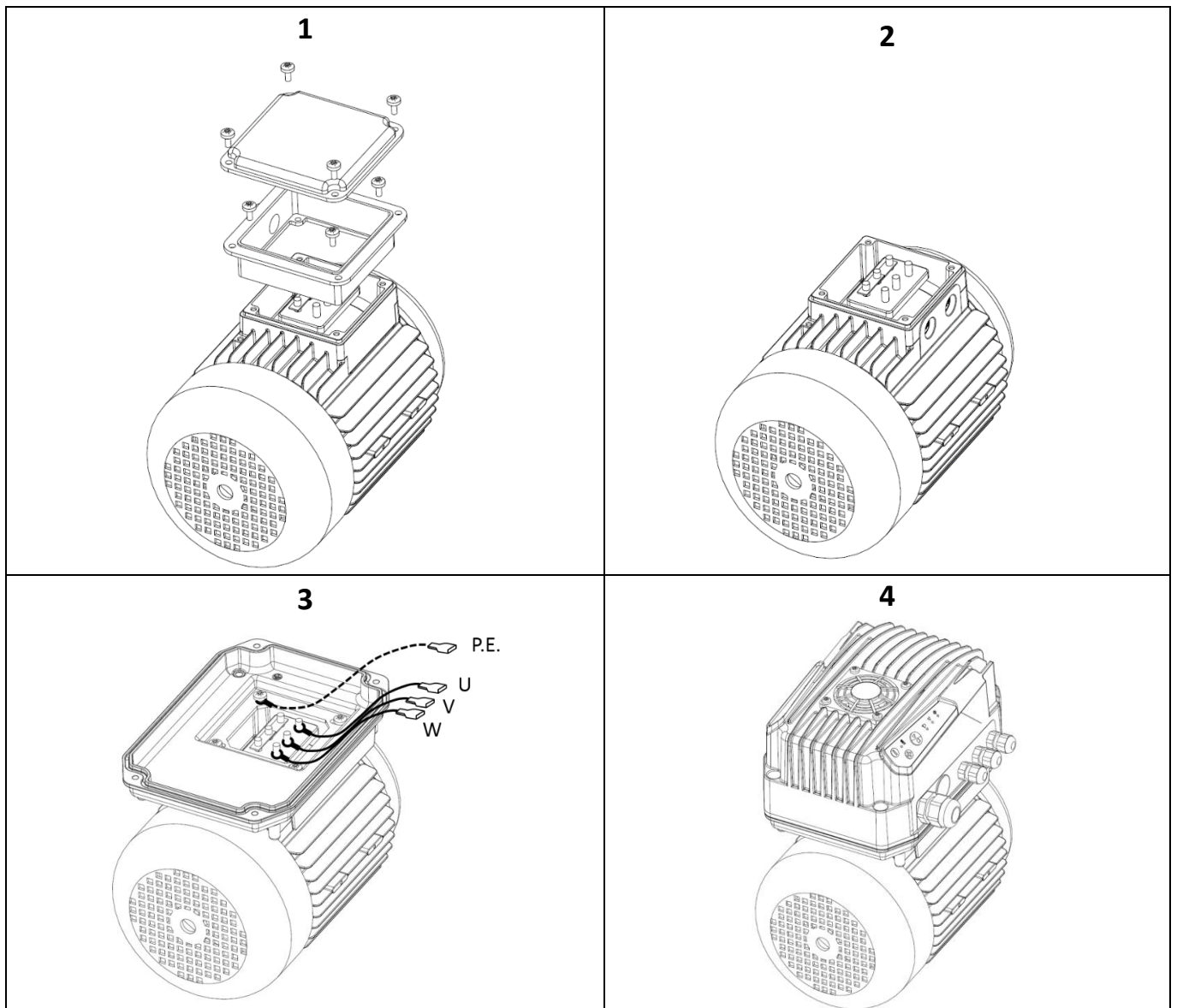
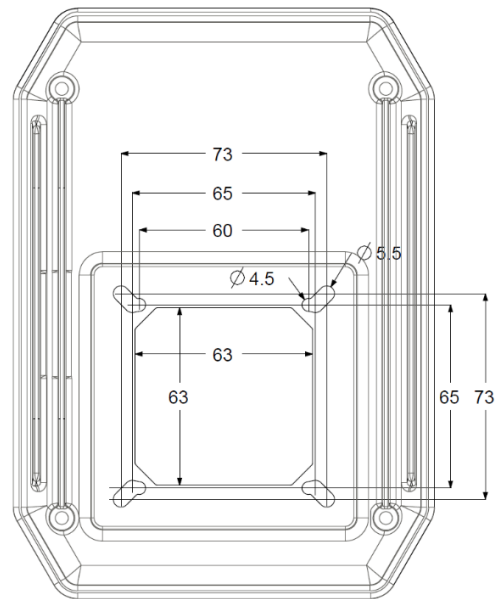

MIDA on wall

When installed on the wall, keep the protective label on MIDA base in order to grant the ingress protection.
Follow below instructions how to fix MIDA base on the wall.

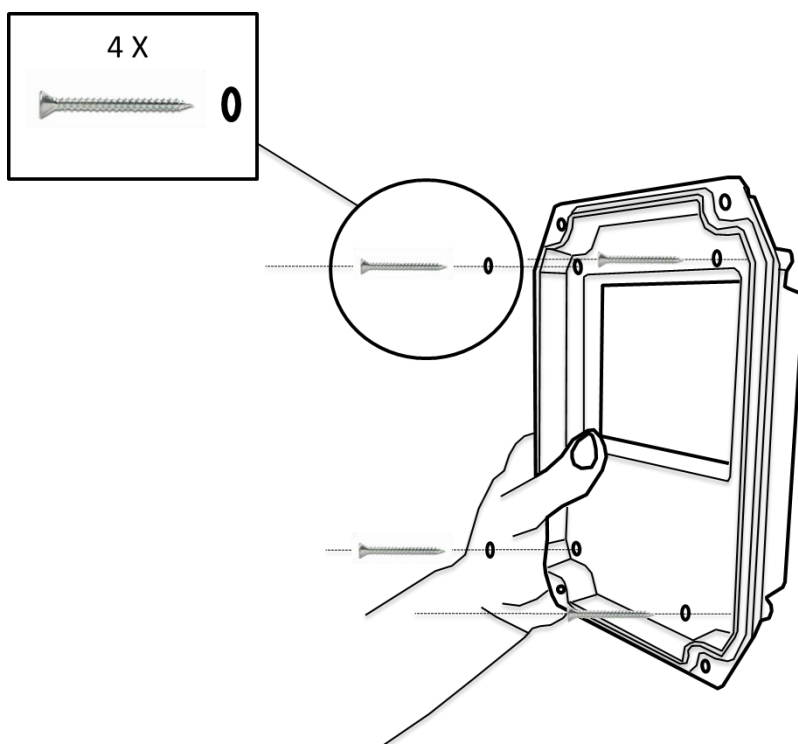
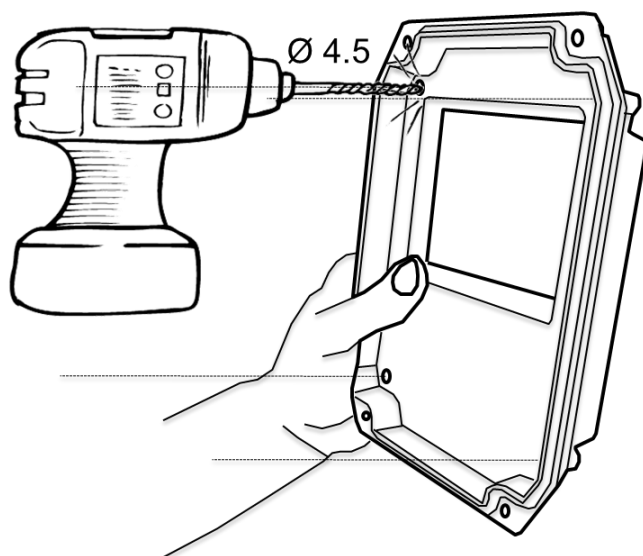

WARNING: use the provided O-rings with screws in order to grant IP protection

4.2 MIDA Installation for constant pressure control

MIDA controls the pump speed to maintain constant pressure at a set point independent of the water demand in the system. A basic schematic is shown below:

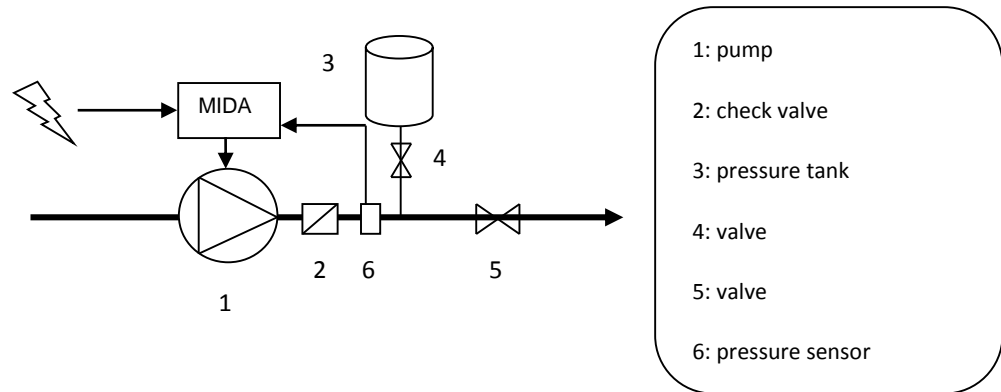

4.2.1 Pressure tank

Installation of a pressure tank in the hydraulic system is recommended to compensate leakage of water in the system (or during minimum water demand) and to avoid continuous start/stop cycling of the pump (check the appendix for more information). Selecting the proper volume and pre-charge pressure of the tank is very important; smaller tank volumes will not compensate adequately for minimum water usage or leakage, while larger volumes make it more difficult for MIDA to control the pressure evenly.

Recommended tank volume is equal to the 10% of the maximum water flow of the system (expressed in volume unit/min)

Example: if the max water flow is 50 liters/min, the pressure tank should have a capacity of 5 liters
 If the max water flow is 20 gpm, the pressure tank should have a capacity of 2 gallons

Pre-charge pressure of the pressure tank should be at least 80% than the set-pressure of the system.

Example: if the set-pressure of the system is 4 bar, the pre-charge pressure of the tank should be 3.2 bar
 If the set-pressure of the system is 60 psi, the pre-charge pressure of the tank should be 48 psi

4.2.2 Pressure sensor

MIDA requires a pressure sensor with a linear output signal within the range 4 – 20 mA. The pressure transducer can be powered by any range of DC Voltage which includes the value 15 V dc.

MIDA accepts the signal of a second pressure sensor in order to:

- realize constant differential pressure (AN1 – AN2).
- substitute first pressure sensor when it fails

SENSOR 1	<ul style="list-style-type: none"> • AN1: 4-20 mA (-) signal • +15V: 15 Vdc (+) power supply
SENSOR 2	<ul style="list-style-type: none"> • AN2: 4-20 mA (-) signal • +15V: 15 Vdc (+) power supply

4.3 MIDA installation for differential constant pressure applications

MIDA can manage the pump speed in order to keep constant the pressure difference between the discharge and suction side of the pump in circulation systems. To do this, it is usually installed a differential pressure sensor. Alternatively, it is possible to use two identical pressure sensors: one in suction side and one in discharge side of the pump. The difference of values is performed by the MIDA itself.

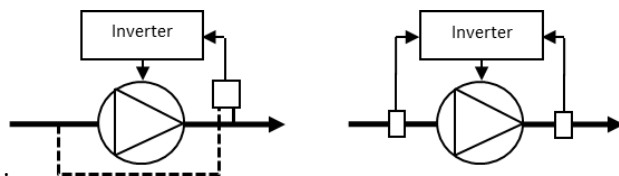

N.B. If during the operation it is expected that the pressure in the suction side falls below the atmospheric pressure, it is necessary to use absolute pressure sensors and not relative ones.

4.3.1 Sensors wiring

MIDA can be connected to linear pressure sensors with 4 - 20 mA output. The supply voltage range of the sensors must include the 15 VDC with which the MIDA feeds the analog inputs.

If you are using a differential pressure sensor it is necessary to connect the sensor to the analog input 1:

DIFFERENTIAL SENSOR	<ul style="list-style-type: none"> • AN1: 4-20 mA (-) signal • +15V: 15 Vdc (+) supply
---------------------	--

In case two pressure sensors are used, the pressure sensor in the discharge side must be connected to the analog input 1 while the pressure sensor in the suction side must be connected to the analog input 2:

SENSOR 1 (discharge)	<ul style="list-style-type: none"> • AN1: 4-20 mA (-) signal • +15V: 15 Vdc (+) supply
SENSOR 2 (suction)	<ul style="list-style-type: none"> • AN2: 4-20 mA (-) signal • +15V: 15 Vdc (+) supply

In the advanced parameters menu it is therefore necessary to set the logic AN1, AN2 as "difference".

4.3.2 Programming

In circulation systems pump starting and stopping is usually controlled by an external contact that can be connected to the digital input 1 (IN1, 0V) and configured as N.O or N.C in the installer parameters menu. It is then recommended to set the following parameters:

Installer parameter	Recommended value
Freq. min control	Same as minimum motor frequency
Delta control	0 bar
Delta start	0 bar
Stop delay	99 sec
Function AN1,AN2	Difference 1-2

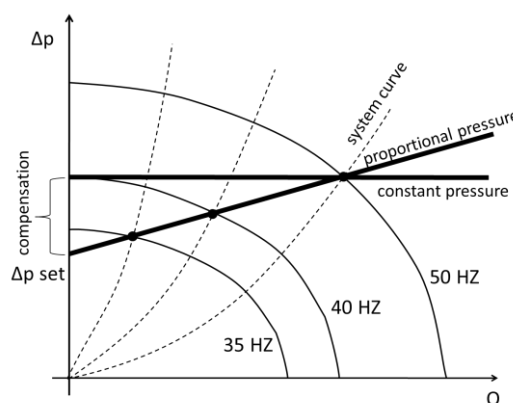

Constant differential pressure

The "set value" corresponds to the differential pressure to be kept constant.

Set the "set value" equal to the pressure difference measured between the discharge and the suction side of the pump at maximum load (all utilities opened) and at maximum frequency (50 Hz).

Proportional differential pressure

In case it is needed to use a control logic based on proportional differential pressure (in order to achieve a further energy saving), it is necessary to set the "set value" equal to the pressure difference between the discharge and suction side of the pump at minimum frequency (20 Hz) and "compensation" in order to reach the maximum set value at maximum frequency (50 Hz) and maximum load (all utilities opened).

5. Electric wiring

MIDA 203,205,207

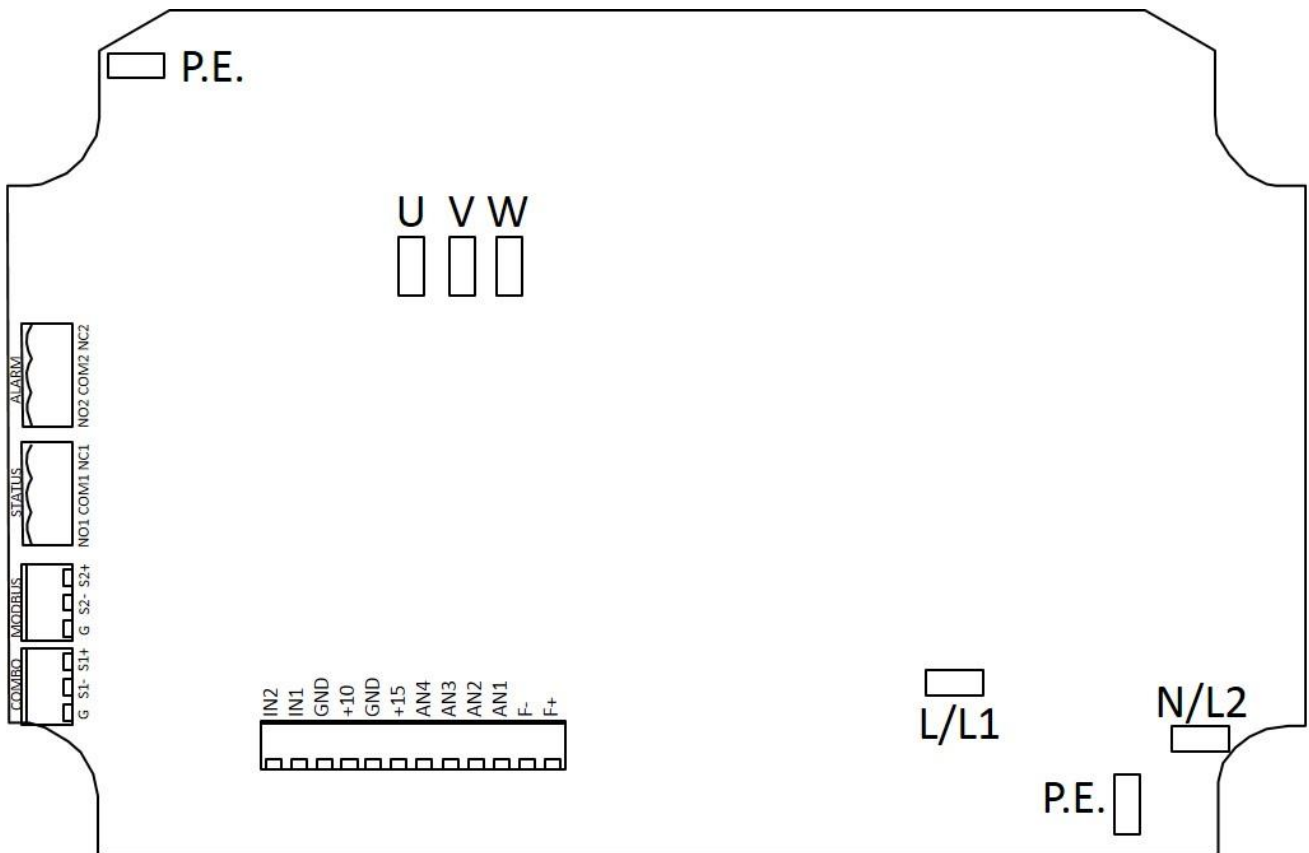

Power supply

- L(L1), N(L2), P.E..

It is recommended to use pre-insulated female faston terminals 6,3x0,8 mm

In order to respect limits of EN61800-3 Category C1 for irradiated disturbs, it is necessary to add a ferrite on input phases L and N. The ferrite and cabling instructions are available on request.

Recommended line cables stripping (without ferrite).

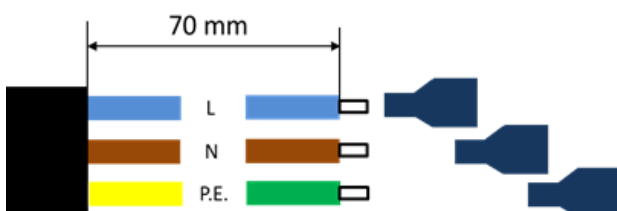

Motor output

- U, V, W, P.E.

It is recommended to use pre-insulated female faston terminals 6,3x0,8 mm.

In case the device is mounted on motor terminal box, it is suggested to use PVC wires 200 mm long with cross section 1.5 mm². In case the device is mounted on the wall, it is recommended using shielded cables of proper cross section depending on cable length and motor power. The screen has to be connected to both side.

Recommended motor cables stripping.

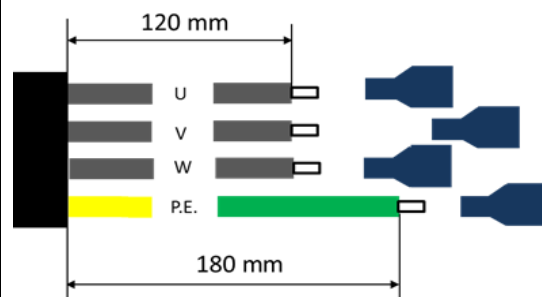

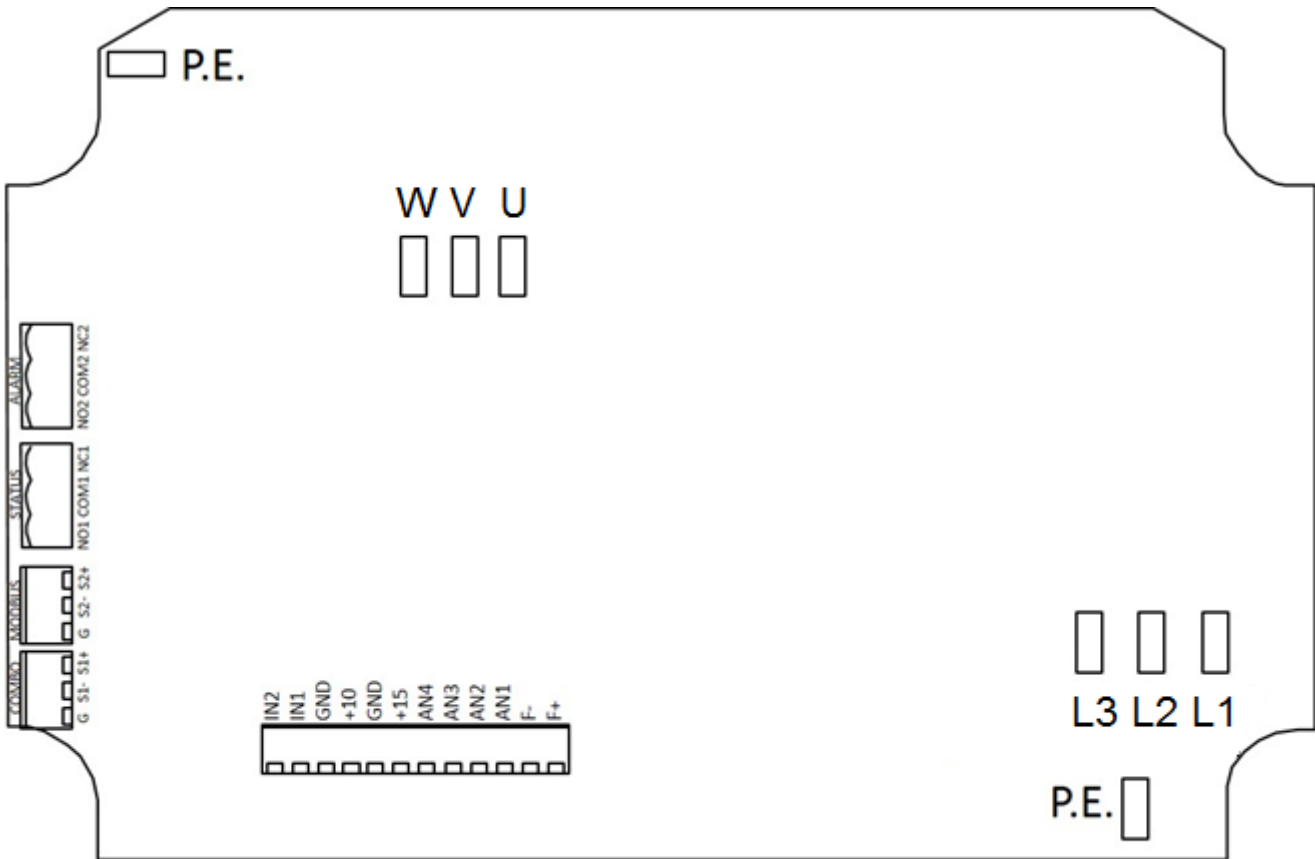

Power supply

- L1, L2, L3, P.E.

It is recommended to use pre-insulated female faston terminals 6,3x0,8 mm.

Recommended line cables stripping.

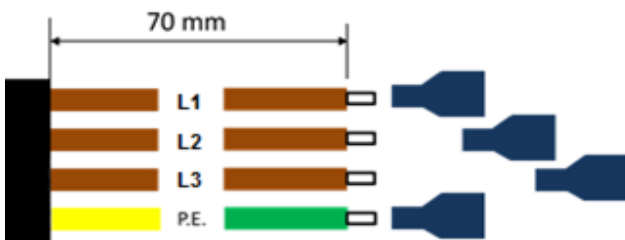

Motor output

- U, V, W, P.E.

It is recommended to use pre-insulated female faston terminals 6,3x0,8 mm.

In case the device is mounted on motor terminal box, it is suggested to use PVC wires 200 mm long with cross section 1.5 mm². In case the device is mounted on the wall, it is recommended using shielded cables of proper cross section depending on cable length and motor power. The screen has to be connected to both side.

Recommended motor cables stripping.

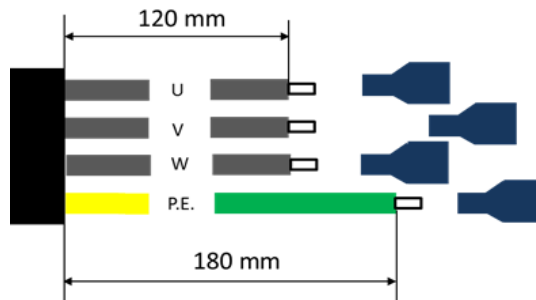

Analog inputs (sensors)

- AN1: 4-20 mA, sensor 1
- AN2: 4-20 mA, sensor 2
- AN3: 0-10 V, external set
- AN4: 0-10 V, trimmer for frequency regulation or external set 2
- +10
- +15

It is recommended to use pre-insulated ferrules.

Use shielded signal cables by placing the screen at one end using the provided EMC clips.

Follow the below figures for correct cable stripping and EMC clip assembling.

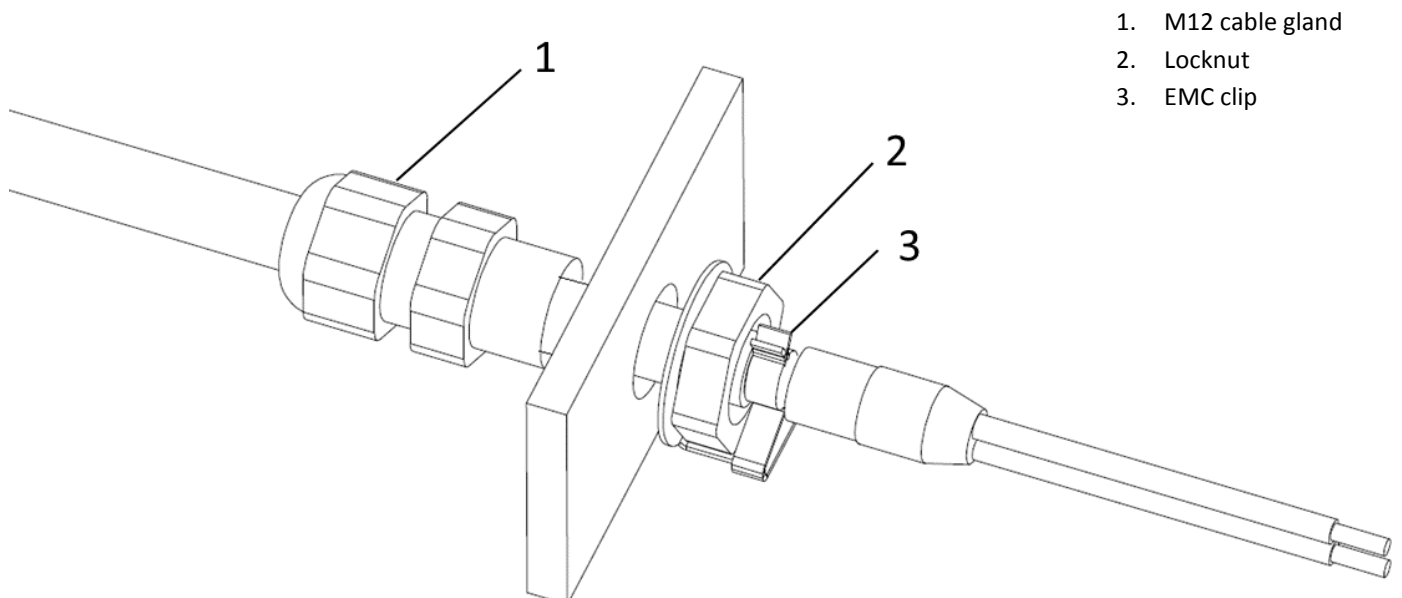
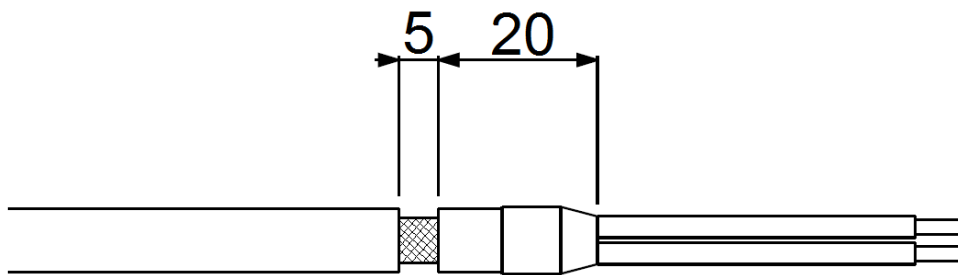

Digital inputs

- **IN1 : motor start / stop**
- **IN2 : motor start / stop or set value 1 - 2 switching***

* only when “control mode: constant value 2 values” is selected.

It is recommended to use only volt free contacts.

Digital inputs can be configured as Normally Open or Normally Closed by software. Read programming chapter.

It is recommended to use pre-insulated ferrules.

Use shielded signal cables by placing the screen at one end using the provided EMC clips.

Digital outputs

- **NO1, COM1 : motor status, closed contact with motor running.**
- **NC1, COM1: motor status, closed contact with motor stopped.**
- **NO2, COM2: alarm status, closed contact without alarm.**
- **NC2, COM2: alarm status, closed contact with alarm or no power supply.**

Relays are volt free contacts. Max. voltage to the contacts is 250 V with max current 5 A.

It is recommended to use pre-insulated ferrules.

Use shielded signal cables by placing the screen at one end using the provided EMC clips.

COMBO serial:

- **S1+, S1-, G**

It is recommended to respect the polarity linking more MIDAs in series (up to 8 units)

It is recommended to use pre-insulated ferrules.

Use shielded signal cables by placing the screen at one end using the provided EMC clips.

MODBUS RTU serial:

- **S2+, S2-, G**

It is recommended to respect the polarity.

It is recommended to use pre-insulated ferrules.

Use shielded signal cables by placing the screen at one end using the provided EMC clips.

5.1 Protections

The protections required upstream each MIDAs depends on the type of installation, and local regulations. We recommend to use overload protection with fuse, circuit breaker type C and residual current device type B sensitive to both AC and DC current.



5.2 Electromagnetic compliance

To ensure electromagnetic compatibility (EMC) of the system, it is necessary to apply the following measures:

- Always connect the device to ground.
- Use shielded signal cables by placing the screen at one end using the EMC clips.
- Use motor cable as short as possible (<1 m / <3 ft). For longer lengths, it is recommended to use shielded cables connecting the screen at both ends.
- Separate signal, motor, and power supply cables.



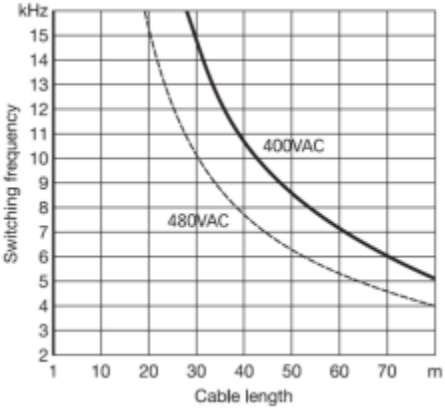



In order to respect limits of EN61800-3 Category C1 for irradiated disturbs, it is necessary to add a ferrite on input phases L and N. The ferrite and cabling instructions are available on request.

5.3 Installation with long motor cables

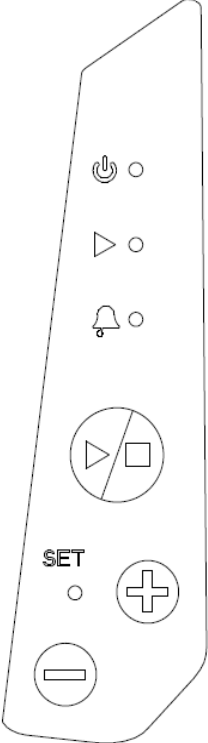
<p>With long motor cables it's recommended to decrease the commutation frequency to 2.5 kHz. This reduces the probability of voltage spikes in the motor windings which may damage the insulation.</p>	
<p>For motor cable lengths up to 50 meters it's recommended to place between MIDA and motor a dV/dt reactance, available on request.</p> 	<p>To prevent dangerous overheating of dV/dt and sinusoidal filters it is recommended to set the correct PWM value in relation to the cable length.</p> <p>For motor cable lengths greater than 50 meters it's recommended to place between MIDA and motor a sinusoidal filter, available on request.</p> 

6. MIDA use and programming

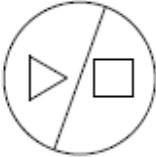
MIDA can be operated in a basic way through the included keyboard.

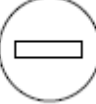
		Stand-by red led	<p>Red led ON: unit is powered with correct input voltage</p> <p>Blinking red led: undervoltage</p>
		Motor running green led	<p>Green led ON: motor is running</p> <p>Green led OFF: motor is stopped</p> <p>When the units is on “constant value” control mode, the green led blinks with higher frequency as much as the measured value is next to set value. If measured value is the same as set value, the green led is steady.</p>
		Alarm yellow led	Yellow led blinks with frequency which depends on alarm type. See “Alarms” chapter.
		Motor start and stop button	<p>Motor start and stop.</p> <p>If the unit is in alarm status, it is possible to try resetting the alarm by pressing the button two times.</p>
		SET green led	<p>Green led is ON when it’s possible to modify the set value (constant value mode) or the set frequency (fix frequency mode). Keep pressed the Up button or the Down button more than 5 seconds in order to enable the set adjusting.</p> <p>If the SET led is off, it is not possible to change the set value.</p> <p>When two or more units are in COMBO mode, the SET led blinks only on master unit. In this way it is possible to understand which unit in the group is the master and thus act on it to start and stop the system.</p> <p>Green led blinks fast when the unit is connected to smartphone and remotely controlled by the App.</p>
		Up button	<p>Through the UP button is possible to increase the set value (constant value mode) or the set frequency (fix frequency mode).</p> <p>In order to allow set changing it is necessary to keep pressed the UP button or the DOWN button more than 5 seconds till the green SET led becomes ON.</p>
		Down button	<p>Through the DOWN button is possible to reduce the set value (constant value mode) or the set frequency (fix frequency mode).</p> <p>In order to allow set changing it is necessary to keep pressed the UP button or the DOWN button more than 5 seconds till the green SET led becomes ON.</p>

6.1 Monitoring and programming

In order to access to parameters monitoring and programming it is necessary to use a smartphone or tablet with Bluetooth 4.0 (BTLE) and Nastec NOW App installed. The App is available on Android, iOS and Windows Mobile and can be downloaded free of charge through the on-line stores.

It is possible to disable the BTLE connection by removing power supply, wait at least 30 seconds till the red STAND-BY led is OFF, keep pressed together START/STOP button and DOWN button and give power supply. Release the buttons after 5 seconds.

It is then possible to enable the BTLE connection by removing power supply, wait at least 30 seconds till the red STAND-BY led is OFF, keep pressed together START/STOP button and UP button and give power supply. Release the buttons after 5 seconds.

Through the App it is possible to:

- Monitor multiple operating parameters simultaneously.
- Get statistics of energy consumption and check alarms history.
- Perform reports with the possibility to insert notes, images and email them or keep them into the digital archive.
- Make programs, save them in the archive, copy them to other devices and share them among multiple users.
- Remotely control, via wi-fi or GSM, a device, using a smartphone nearby as a modem.
- Access to manuals and additional documentation.
- Have on-line help on parameters and alarms details.

6.1.1 Monitoring

Following parameters can be monitored through the App in “Monitor” selection.

Actual value [bar]	Actual value is the value read by the sensor.
Set value [bar]	Set value is the value which has to be kept constant.
Frequency [Hz]	Motor running frequency.
Voltage Bus DC [V]	DC voltage on capacitor bus.
Motor current [A]	Phase current absorbed by the motor.
Motor power factor	Motor cosphi (P.F.).
Power [W]	Electrical power absorbed by the motor.
Module temperature [°C]	IGBT module temperature.
PCB temperature [°C]	Printed circuit board temperature.
Inverter hours [h]	Total inverter hours.
Motor hours [h]	Total motor running hours.
Address	Unit address when in COMBO mode.
ALARM HISTORY	Record of last 8 alarms.

6.1.2 Programming

Parameters are organized in four main menus: CONTROL, MOTOR, IN/OUT, CONNECT.

Parameters are password protected in 2 levels of access:

- **Installer level (CONTROL, IN/OUT). Password: 001**
- **Advanced level (MOTOR, CONNECT). Password: 002**

IN/OUT PARAMETERS

Parameter	Default	Description
Unit XXXXX	bar	Unit [bar,%,ft,in,cm,m,K,F,C,gpm,l/min,m3/h,atm,psi]
F. scale sensor XXX.X	16	Sensor full scale.
Min.value sensor XXX.X	0	Sensor minimum value.
Offset input 1 [%]	20%	Zero correction for analog input 1 (4-20 mA) (20 mA x 20% = 4 mA).
Offset input 2 [%]	20%	Zero correction for analog input 2 (4-20 mA) (20 mA x 20% = 4 mA).
Offset input 3 [%]	0%	Zero correction for analog input 3 (0-10V) (10V x 00% = 0 V).
Offset input 4 [%]	0%	Zero correction for analog input 4 (0-10V) (10V x 00% = 0 V).
AN1,AN2 function XXXXXX	Independent	Function logic for analog input AN1,AN2 (independent, lower value, higher value, difference 1-2).
Digital input 1 N.O. / N.C.	N.O.	By selecting N.O. (normally open) MIDA runs the motor if the digital input 1 is open; motor will be stopped if the digital input 1 is closed. By selecting N.C. (normally closed) MIDA runs the motor if the digital input 1 is closed; motor will be stopped if the digital input 1 is opened.
Digital input 2 N.O. / N.C.	N.O.	By selecting N.O. (normally open) MIDA runs the motor if the digital input 2 is open; motor will be stopped if the digital input 2 is closed. By selecting N.C. (normally closed) MIDA runs the motor if the digital input 2 is closed; motor will be stopped if the digital input 2 is opened.

Parameter	Default	Description
Dig. input 1 manual reset Enable / Disable	Disable	Enabling or disabling digital input 1 manual reset.
Dig. input 2 manual reset Enable / Disable	Disable	Enabling or disabling digital input 2 manual reset.
Dig.In.2 delay [s]	3	Digital input IN2 delay. Digital input IN1 has 1 second fix delay.

CONTROL PARAMETERS

Parameter	Default	Description	Constant value	Fix speed	Const.value 2 set	Fix speed 2 val.	External speed
Control mode <ul style="list-style-type: none"> Constant value Fix speed Const.value 2set Fix speed 2 val. External speed 	Constant value	Mode of control: <ul style="list-style-type: none"> Constant value: MIDA changes the pump speed to keep the set value constant regardless water demand. Fix speed: MIDA feeds the pump at set frequency, so the pump speed is kept constant. Const. value 2 set: the two values are selected by opening or closing the digital input IN2. Fix speed 2 val: the two values are selected by opening or closing the digital input IN2. External speed: control motor frequency by using analogical input AN4. 					
Max alarm value XXX.X [bar]	10	Maximum value allowed in the system. If the readen value goes over this value, an alarm occurs and the pump is stopped. Pump is automatically restarted if the readen value goes below the maximum value for a period of at least 5 seconds.	✓	✓	✓	✓	✓
Min alarm value XXX.X [bar]	0	Minimum value allowed in the system. If the readen value goes lower than this value, an alarm occurs and the pump is stopped. Pump is automatically restarted if the readen value goes higher than the minimum value for a period of at least 5 seconds.	✓	✓	✓	✓	✓
Ext.set enabling ON/OFF	OFF	Enabling of set value changing by analog input AN3.	✓		✓		
Set value XXX.X [bar]	3	Set value to be kept constant.	✓				

Parameter	Default	Description	Constant value	Fix speed	Const. value 2 set	Fix speed 2 val.	External speed
Compensation XXX.X [bar]	0	Value compensation at the maximum frequency for each pump. Acting on the green button you can reverse the sign.	✓				
Set value 2 XXX.X [bar]	3	Set value to be kept constant.			✓		
Compensation 2 XXX.X [bar]	0	Value compensation at the maximum frequency for each pump. Acting on the green button you can reverse the sign.			✓		
Set value update XX [s]	5	Time to update set value for compensation.	✓		✓		

To ensure proper operation of pressure control is recommended to place the sensor near the pump.
To compensate the pressure loss in the pipes (proportional to flow) it is possible to vary the pressure set in a linear relation with respect to frequency.

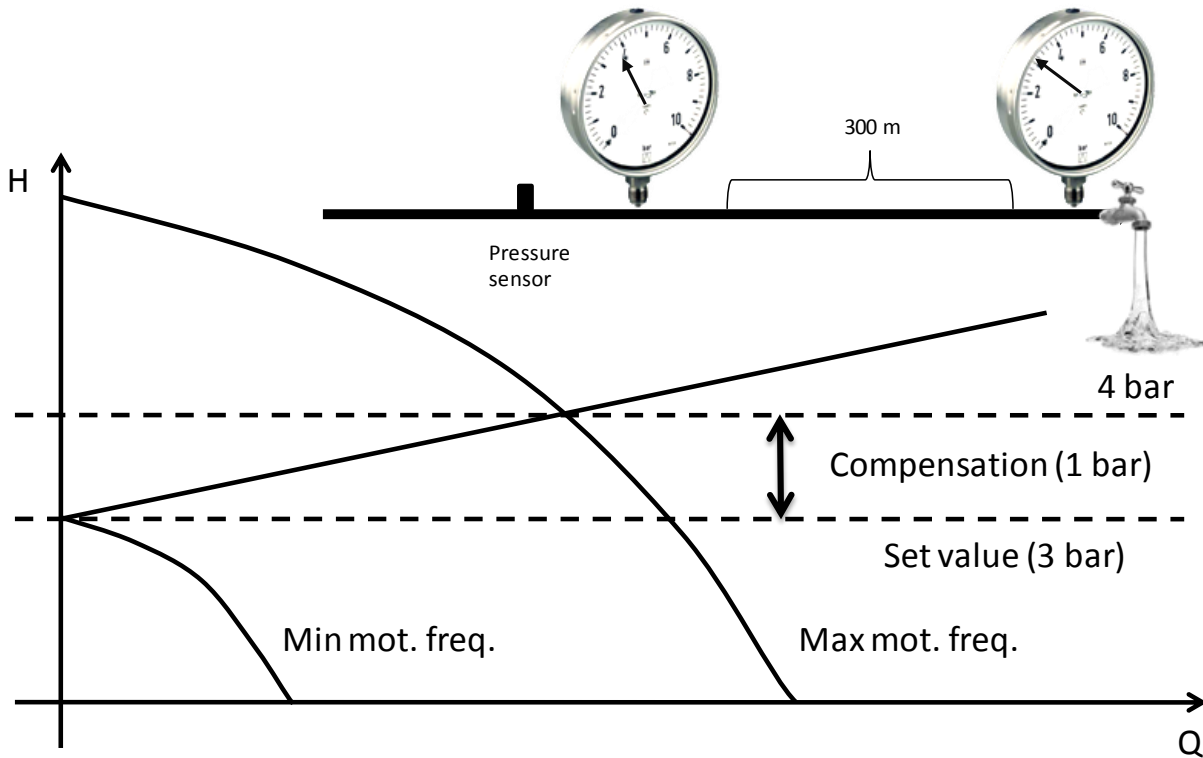

It can perform the following test to verify the correct value of compensation:

1. install a pressure gauge away from the pressure sensor
2. open completely the valve
3. check the pressure gauge

--> Set the value of *compensation*. equal to the difference of the values from the two gauges.

When using a group of pumps, the pressure compensation to be applied to each pump is equal to the total pressure compensation (when all the pumps are running at full speed) divided by the number of pumps in the group.

Operating freq. XXX [Hz]	50	Frequency value to feed the pump.		✓			
-----------------------------	----	-----------------------------------	--	---	--	--	--

Parameter	Default	Description	Constant value	Fix speed	Const. value 2 set	Fix speed 2 val.	External speed
Operating freq. 2 XXX [Hz]	50	Frequency value to feed the pump.				✓	
Freq.min.control XXX [Hz]	50	Minimum frequency below which the pump tries to stop.	✓		✓		✓
Stop delay XX [s]	5	Delay for which the pump tries to stop below freq.min.control.	✓		✓		✓
Control ramp XXX.X [s]	20	Ramp time from freq.min.control to min.motor freq. If, during this time, the read value goes below the (set value - delta control), MIDA powers the motor again; otherwise, MIDA will stop the pump.	✓		✓		✓
Delta control XXX.X [bar]	0.1	Value drop below the set value required to restart the pump during control ramp.	✓		✓		

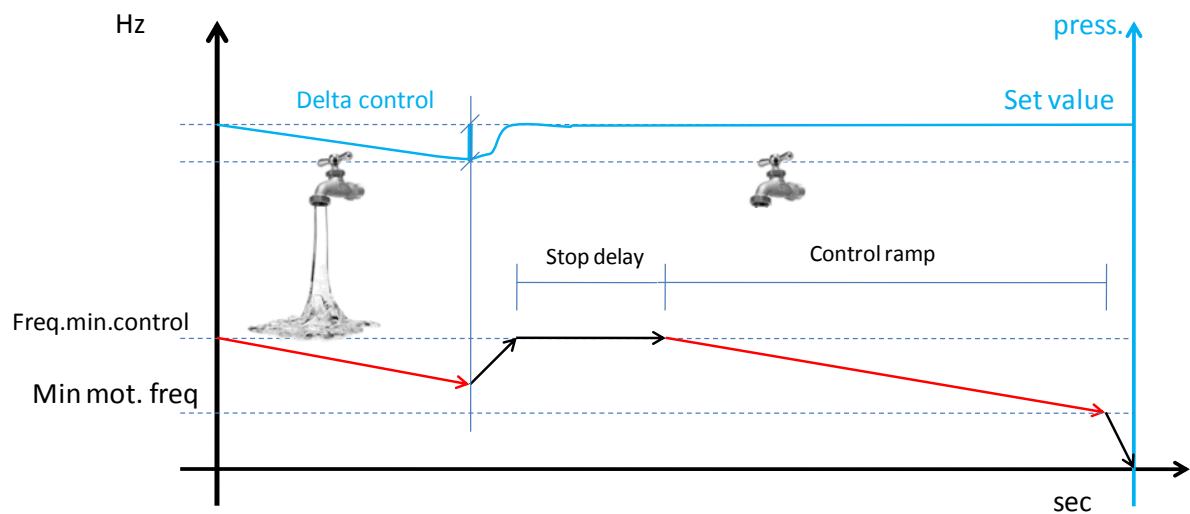

Delta start XXX.X [bar]	0.5	Value drop below the set value required to start the pump from stop condition.	✓		✓		
Delta stop XXX.X [bar]	0.5	Value increase respect to set value which must be passed so that there is a forced shutdown of the pump.	✓		✓		

Parameter	Default	Description	Constant value	Fix speed	Const.value 2 set	Fix speed 2 val.	External speed
Ki		Kp and Ki parameters allow the dynamic control of system by MIDA; set values (Ki=50, Kp=005) are usually enough to get a valid dynamic control.	✓		✓		
Kp							
COMBO ON/OFF	OFF	Enabling or disabling COMBO operation as described in COMBO chapter.	✓		✓		
Address XX	00	MIDA address: <ul style="list-style-type: none"> • 00 master • 01 to 07 slaves 	✓		✓		
Alternance ON/OFF	OFF	Function to allow alternating between the MIDAs connected in COMBO in order to allow equal use of each pump in the group; master will reorganize the starting priority of the pumps by checking the life of each of them.	✓		✓		
Alternance period XX [h]	0	Maximum difference in terms of hours between MIDAs in the group. 0 stays for 5 minutes.	✓		✓		
COMBO synchrony ON/OFF	OFF	With this parameter it is possible to activate the synchronous operation (same speed) of the pumps in COMBO. It is however necessary to appropriately lower the parameter "f. min. control".	✓		✓		
Start delay AUX t = XX [s]	0	Delay time with which the slaves start after the variable speed pump has reached the maximum frequency and the pressure value has fallen below set value – delta control	✓		✓		
PI control Direct/Reverse	Direct	Direct: increasing motor speed also misured value increases Reverse: increasing motor speed, misured value decreases.	✓		✓		
Periodic autorun t = XX [h]	0	Pump periodic autorun after XX hours of inactivity. Value 0 makes function disabled. <u>Warning</u> , review the advice in chapter 1.	✓	✓	✓	✓	✓
Dry run cosphi X.XX	0.65	Cosphi value below which the unit stops the motor and give “no water” alarm.	✓	✓	✓	✓	✓
Restarts delay XX [min]	10	Restart delay after a dry running alarm. At each tentative (max 5) restart delay will be doubled.	✓	✓	✓	✓	✓

MOTOR PARAMETERS

Parameters	Default	Description
Motor type XXXXXX	Three phase	<ul style="list-style-type: none"> • Threephase asynchronous • Synchronous PM • Singlephase • Scalar V/f
Rated motor Volt. XXX [V]	XXX	Motor rated voltage (as shown on motor nameplate).
Voltage boost XX.X [%]	0%	Voltage increase during the motor start up. Warning: An excessive value can seriously damage the motor. Contact the motor manufacturer for further information.
Rated motor Amp. XX.X [A]	XX	Rated motor current as per its nameplate indication increased by 5%.
Rated motor freq XXX [Hz]	50	Rated motor frequency as per its nameplate.
Max motor freq. XXX [Hz]	50	Maximum motor frequency. Note: by reducing the maximum motor frequency, maximum current will be reduced as well.
Min motor freq. XXX [Hz]	20	Minimum motor frequency.
Ramp up time XXX.X [sec]	4	Ramp-up time to reach the speed required to achieve the set pressure (or frequency value). Longer times delay the system reaching the preset value but better protect system components. Excessively long ramp-up times can create difficulties in MIDA setup, and can also cause false overload alarms.
Ramp down time XXX.X [sec]	4	Ramp-down time to reach zero speed. Longer times keep the system pressurized, while protecting the system components. Excessively long ramp-down times can create difficulties in MIDA setup. Excessively short ramp-down times can cause false overload alarms.
Ramp f min mot. XXX.X [sec]	1.5	Time to reach the minimum motor frequency and vice versa.

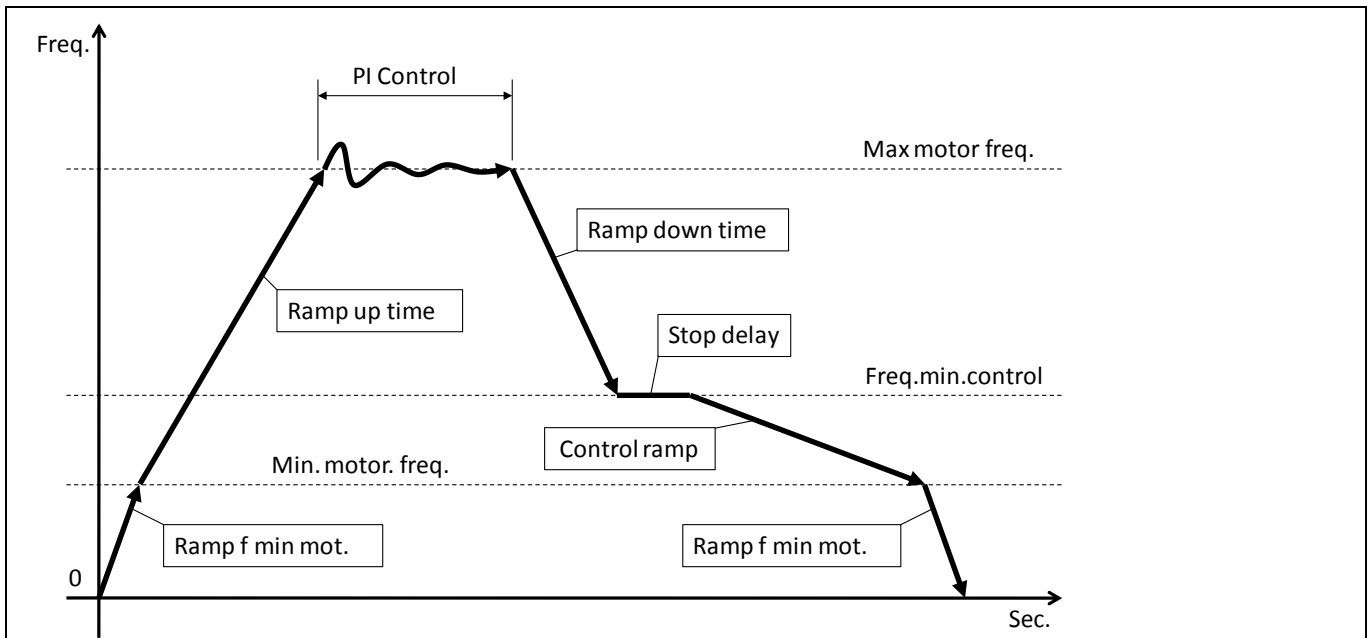

<p>PWM XX.X [kHz]</p>	<p>8</p>	<p>Carrier frequency (switching frequency). It is possible to choose PWM in the range of 2.5 ,4, 6, 8, 10 kHz . Higher values give a more sinusoidal wave with fewer losses for the motor but higher losses for the inverter (increased inverter heating). If long cables are used (>20 m / >76 ft) (submersible pump) it is recommended to install an inductive filter between MIDA and the motor (available upon request) and to set the value of PWM to 2.5 kHz. This reduces the risk of voltage spikes, which can damage motor and cable insulation.</p>
<p>V/f lin. --> quad. XXX [%]</p>	<p>85 %</p>	<p>V / f characteristic with which MIDA feeds the engine. The linear characteristic corresponds to constant torque with variable speed. The quadratic characteristic is normally used with centrifugal pumps. The selection of torque characteristic should be done ensuring a smooth operation, a reduction of energy consumption and a lower level of heat and acoustic noise.</p>

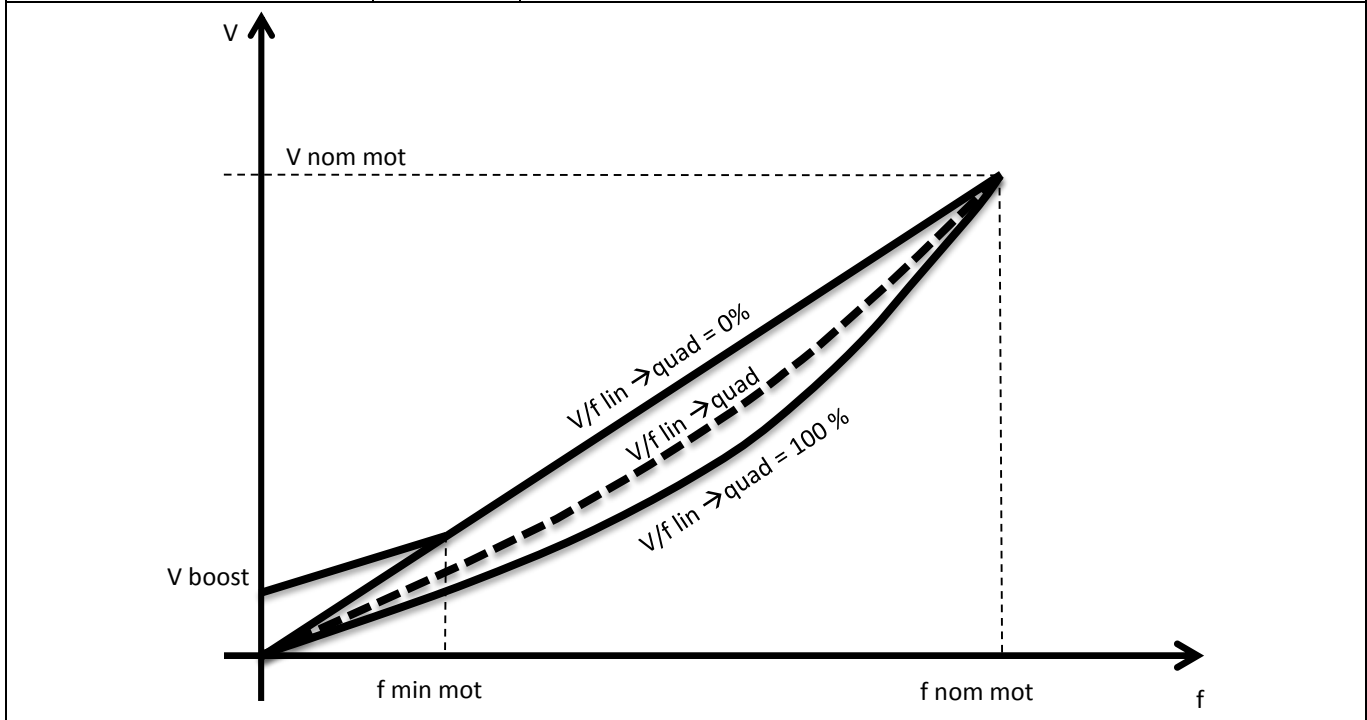

<p>Rotation sense ---> / <---</p>	<p>---></p>	<p>If, during the test, the motor runs in reverse, it is possible to change the wiring sequence via software without physically changing wires at the terminals.</p>
---	----------------	--

MOTOR TUNING press ENT		If the device is "FOC-ready", motor calibration must be carried out before commissioning. Carefully read the pertinent chapter.
Mot. resistance Rs=XXX.XX [Ohm]		Manual setting of the stator resistance.
Mot. inductance Ls=XXX.XX [mH]		Manual setting of the stator inductance.
FOC dynamic XXX		Setting of the control dynamic of the FOC algorithm.
FOC speed XXX	5	Setting of the control speed of the FOC algorithm.
Autorestart ON/OFF	OFF	If ON is selected, after a lack of voltage, MIDA returns to its normal status; if MIDA was powering the pump before the voltage drop, it resumes powering the pump automatically. <u>Warning</u> , review the advice in chapter 1.

CONNECTIVITY PARAMETERS

Parameters	Default	Description
MODBUS address XXX	1	MODBUS address from 1 to 247
MODBUS baudrate XXXXX [bps]	9600	MODBUS baudrate from 1200 bps to 57600 bps
MODBUS data format XXXXX	RTU N81	MODBUS data format: RTU N81, RTU N82, RTU E81, ETU O81

6.1.3 FOC motor control

Introduction

FOC (Field Oriented Control) motor control implemented in FOC-ready inverters provides the following advantages compared to traditional control:

- Optimal control of the current at each work point.
- Quick and precise speed adjustment.
- Lower energy consumption.
- Reduction of torque oscillations (vibrations) for smoother and more regular operation throughout the frequency range and lower system noise.
- Lower mechanical stress on the motor, pump and hydraulic system.

FOC control of FOC-ready devices can be used with:

- Asynchronous three-phase motors
- Permanent magnet three-phase synchronous motors

The control is sensorless, i.e. not requiring the use of any sensors.

Calibration of the FOC control

To enable the device to perform FOC control, it is necessary to:

1. Perform all system wiring. Connect the load (pump) to the inverter with a cable of appropriate length and possible presence of a dV/dt or sinusoidal filter.
2. Power the system and follow the initial configuration procedure by specifying:
 - a) Motor type: three-phase asynchronous or permanent magnet synchronous.
 - b) Rated voltage of the motor.
 - c) Rated frequency of the motor.
 - d) Rated current of the motor increased by 5%.
3. Perform the Auto tuning process to allow the inverter to learn the electrical information of the load connected to it (motor, cable and any filter). The calibration process can take up to one minute.
4. Wait for the calibration process to complete successfully.



During the calibration process the motor remains stationary but is powered for the entire calibration period.

Disconnect the device from the power supply before any intervention on the equipment and on the loads connected to it.

Carefully follow the safety instructions in the installation and operating manual of the device.



The calibration process can take up to one minute. Wait until it has completed.

The calibration process must be performed during the final electrical configuration of the system, i.e. with the motor, the cable and any filter applied.

If there is any variation of the motor, cable or filter applied, it is necessary to repeat the calibration process by accessing the motor parameters menu (default password 002).

An incorrect configuration of the motor's rated voltage, frequency or current will lead to erroneous results in the calibration process and therefore to a malfunctioning of the motor.

Setting the rated motor current higher than the tag value can seriously damage both the motor and the inverter.

During calibration the motor coils are heated by the test current. If the motor is self-ventilated the absence of motor rotation does not allow the heat to be dispersed by force.

It is therefore recommended to allow the motor to cool between one calibration and the next.

If the calibration process is not successful, it is necessary to check:

- The connections between the inverter and the load (including any motor filters in between).
- The rated voltage, frequency and current values set.

	<p>The motor cannot be started until the calibration process has been completed. If the calibration process cannot be completed, it is possible to manually enter the parameters or stator resistance (Rs) and stator inductance (Ls) in the motor parameters menu (default password 002). These data can be provided by the motor manufacturer or obtained through measurements. If you do not have these data and the self calibration process is not successful, it is recommended to contact technical assistance.</p>
---	---

Adjustment of the FOC control

The FOC control algorithm checks current (torque) and speed with defined response dynamics.

The FOC dynamic is set by default to a value sufficient to guarantee precise and oscillation-free control in most applications.

In some cases, however, it may be necessary to increase (if there are frequency oscillations) or to lower (in the event of overcurrent or igbt trip alarms) the "FOC dynamic" setting in the motor parameters menu (default password 002) according to the following table :

CONFIGURATION	FOC DYNAMIC
Motor cables shorter than 100 m and no filter between inverter and motor.	200
Motor cables shorter than 100 m and a dV/dt filter between the inverter and the motor.	150
Motor cables longer than 100 m and a dV/dt filter between the inverter and the motor.	100
Presence of a sinusoidal filter between the inverter and the motor.	50

	<p>The incorrect setting of the FOC dynamic can cause:</p> <ul style="list-style-type: none"> • Speed oscillations if the FOC dynamic is too slow. • Overcurrent or igbt trip alarms if the FOC dynamic is too fast. <p>It is recommended to intervene promptly by appropriately adjusting the "FOC Dynamic" parameter if the conditions listed above are present. Lack of intervention could lead to damage to the inverter, the motor and the system.</p>
---	---

6.2 COMBO operation

COMBO serial connection

MIDA's communication is made through a private protocol using the COMBO serial port. Each MIDA (up to 8 units) have to be connected to each other by using a tripolar cable (0,5 mm²) wired on S1+,S1-,G pins.

To achieve the COMBO function in a system consisting of several interconnected MIDAs, use a sensor connected to each MIDA.

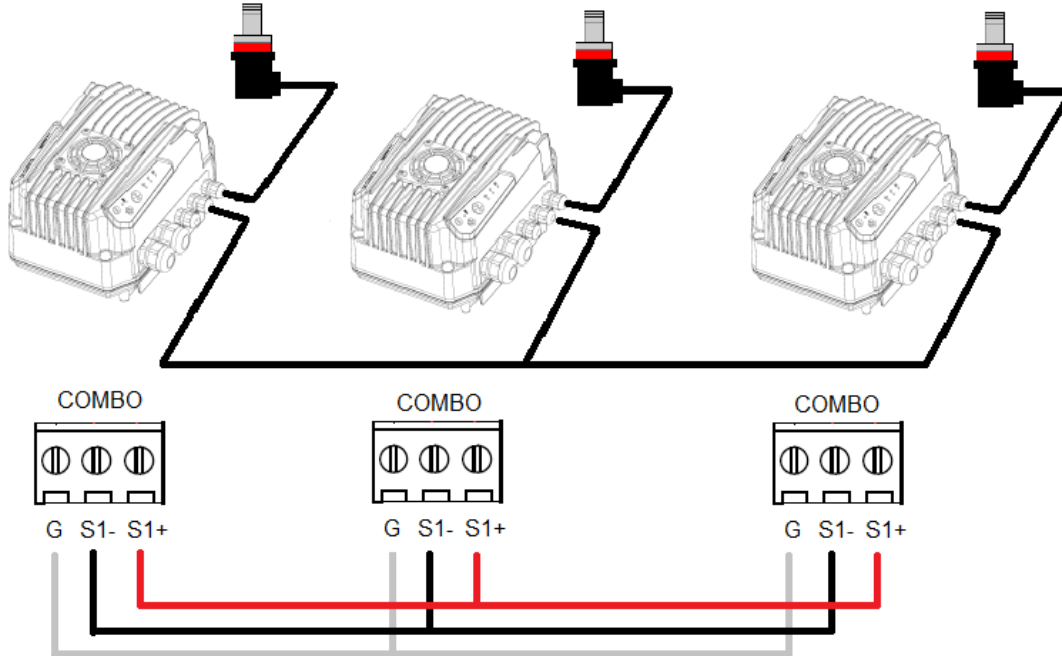

Master setup

COMBO ON/OFF	Activate COMBO function by setting ON
Address XX	Set master address as 00
Alternance ON/OFF	Function to allow alternating between the MIDAs connected in parallel in order to allow equal use of each pump in the group; in this way Master will reorganize the starting priority of the pumps by checking the life of each of them.
Alternance period XX [h]	Maximum difference in terms of hours between MIDAs in the group. 0 stays for 5 minutes.
COMBO synchrony ON/OFF	With this parameter it is possible to activate the synchronous operation (same speed) of the pumps in COMBO. It is however necessary to appropriately lower the parameter "f. min. control".
Start delay AUX XX [s]	Delay time with which the slaves start after the variable speed pump has reached the maximum frequency and the measured value has fallen below set value – delta control.
AUTORESTART ON/OFF	Set Autorestart to ON in order to allow master replacement in case of failure.

Slave setup

In case of failure of the master in a Combo system, it will be replaced by slaves (with priority based on slave address). As a consequence, all parameters must be setup on each units. It recommend to use "Copy to" function to program slaves unit starting from master programming.

On each slave unit, it is then necessary to specify the correct address:

<div style="border: 1px solid black; padding: 5px; width: fit-content; margin: 0 auto;"> Address XX </div>	Set slave address as: <ul style="list-style-type: none"> • 01 : slave 1 • 02 : slave 2 • 0n : slave n • 07 : slave 8
---	--

In case of alarm or failure of a slave unit in a Combo system, this unit operation will be replaced (temporary or permanently) by another slave.

In case of failure of the master in a Combo system, it will be replaced by slaves (with priority based on slave address) within 1 minute. In order to enable master replacement Autorestart must be set ON in each slaves.

7. Protections and alarms

ALARM MESSAGE	LED NOTIFICATION	ALARM DESCRIPTION	POSSIBLE SOLUTIONS
UNDER VOLTAGE	Red STAND-BY led blinking	Supply voltage too low	Check possible causes of undervoltage.
OVER VOLTAGE	Red STAND-BY led and yellow ALARM led blinking	Supply voltage too high	Check possible causes of overvoltage.
DRY RUN COSPHI	Yellow ALARM led 1 blink	Motor cosphi is lower than the set dry running cosphi.	<ul style="list-style-type: none"> • Check if the pump is primed. • Check the set dry running cosphi. Dry running cosphi is approximately 60% of the rated cosphi (at rated frequency) listed on the motor plate. <p>If pump's cosphi is lower than the set dry-running cosphi for at least 2 seconds, MIDA stops the pump. MIDA tries to run the pump every 10, 20, 40, 80, 160 minutes and then the pump is stopped.</p> <p>WARNING: if dry running protection occurs, MIDA will try to start the pump automatically. Be sure to cut power supply to MIDA before performing any maintenance.</p>
OVERCURRENT MOT.	Yellow ALARM led 2 blinks	Motor overload: motor current is higher than the	

		rated motor current setting parameter.	Make sure that the motor current setting parameter is at least 5% higher than rated. Check other possible causes of over current.
SENSOR FAULT	Yellow ALARM led 3 blinks	Sensor error	<ul style="list-style-type: none"> • Check the transducer • Check the wiring of transducer
OVER TEMP. INV.	Yellow ALARM led 4 blinks	Inverter over temperature	<ul style="list-style-type: none"> • Make sure that ambient temperature is less than 40 °C (104 °F). • Check if cooling fan is working properly and if mounting space is adequate for proper cooling. • Reduce the PWM value
IGBT TRIP ALARM	Yellow ALARM led 5 blinks	The current drawn by the load exceeds the capacity of MIDA or inverter power module (IGBT) is failed.	<ul style="list-style-type: none"> • Decrease the ramp-up time • Check the voltage drop along the supply cable to the motor. • Check motor insulation
NO COMMUNICATION	Yellow ALARM led 6 blinks	Communication between master and slave(s) has been interrupted.	<ul style="list-style-type: none"> • Check the wiring connections
MAX. VALUE ALARM	Yellow ALARM led 7 blinks	Measured value has reached the maximum value accepted by the system.	<ul style="list-style-type: none"> • Check possible causes of reaching max value • Check the max alarm value setting
MIN. VALUE ALARM	Yellow ALARM led 8 blinks	Measured value has reached the lowest value accepted by the system.	<ul style="list-style-type: none"> • Check possible causes reaching min value (i.e. broken pipe, open pressure relief valve, etc.) • Check the min alarm value setting.
ADDRESS ERROR	Yellow ALARM led 9 blinks	Two units with master address in the group	<ul style="list-style-type: none"> • Check units address
ALARM CPU	Yellow ALARM led 10 blinks	Error on CPU	<ul style="list-style-type: none"> • Contact technical service
ACTIVE DIGITAL INPUT	Yellow ALARM led fast blinking	Digital input activated	<ul style="list-style-type: none"> • Check digital input connections.

EC DECLARATION OF CONFORMITY

In according with:

Machine Directive 2006/42/EC

EMC Directive 2014/30/CE

Low Voltage Directive 2014/35/CE

R&TTE Directive 2014/53/EU

RoHS Directive 2011/65/EU

We, Nastec srl, via della Tecnica, 8, 36021, Barbarano Mossano, Vicenza, Italy, declare that:

MIDA is an electronic device to be connected to other electrical equipment with which it is to form individual units. It must, therefore, that the putting into service of this unit (with all its subsidiary equipments) to be performed by qualified personnel.

The product conforms to the following regulations:

EN 61800-3

EN 61000-3-2

EN 61000-3-3

EN 61000-6-1

EN 61000-6-3

EN 61000-4-2

EN 61000-4-3

EN 61000-4-4

EN 61000-4-5

EN 61000-4-6

EN 61000-4-8

EN 61000-4-11

EN 60335-1

ETSI EN 300 328

Mossano, 10/01/2018

Ing. Marco Nassuato
Operation Manager



