



**AUSSIE QUIK PRIME
6" MQ TRAILER OR SKID MOUNTED TRASH PUMP (MQ600TD)**



MQ600TD trailer mounted trash pump

Features

- Huge 6,000 litres per minute flow with 6" suction & discharge ports
- Highest head in it's class of 46 metres (64.9 psi)
- Self priming from a depth of 7.6m
- Reliable, low maintenance 80HP Deutz (F4L914) air cooled, four cylinder diesel engine with electric start (note: battery are not included). 2 year engine warranty
- Built in safety shutdown for low oil pressure, oil temperature & V-belt failure
- Oil lubricated tungsten titanium carbide seals standard
- Wear resistant volute and impeller ensures minimal clogging and can handle solids up to 76mm (3") in diameter
- Easy clean-out port can be removed in seconds
- 90° discharge elbow can be rotated based on job requirements
- Heavy duty non-registrable site trailer with tow end jack stand or skid mount options
- Control panel shock mounted in water resistant housing, includes hourmeter, ammeter, tachometer and alternator failure light
- Pump and engine skid can be easily removed from trailer
- 152 litre fuel tank incorporated in base of skid
- Weighs 1111 kg ,and it has a lifting bar as standard equipment (960 kg for skid mounted version)
- Strainer included to prevent entry of oversized solids
- Bearing and mechanical seal sight glasses
- Marine type battery box
- Convenient integrated manual box

Engineered to meet the requirements of professional contractors, rugged and dependable, these diesel powered trash pumps are ideal for de-watering applications with high solid content.

The simple, self priming design makes them fast to set up and easy to maintain.

Applications:

- De-watering
- Tailing dam pump out
- Public works
- Slurry pumping
- Flood mitigation
- Sewage transfer

Benefits

- » Fast de-watering for even large scale jobs
- » Ideal for de-watering duties even over distance
- » Quick and easy to set up pump ready for work
- » Loads of power, readily available parts & service
- » Protection for both the operator and the pump
- » Extended seal life, cuts maintenance costs
- » Suits pumping solid laden liquids, i.e. site de-watering
- » Blockages can be cleared without removing connected pipes and without special tools
- » Greater flexibility to adjust discharge direction
- » Facilitate transportation on site
- » Protection in dusty ,wet environments, convenient operator preventative maintenance
- » Allows pump to be mounted on other equipment
- » Enables long running between refuels, approx. 11 hours (uses @12 litres per hour)
- » Pumps are balanced and can be safely craned
- » Prevents clogging and subsequent maintenance
- » Enables quick checks to ensure lubricant level correct
- » Protects battery from moisture
- » Operator 's manual readily available

Due to our program of continuous product development the manufacturer reserves the right to alter specifications without notice.



AUSSIE QUIK PRIME 6" MQ TRAILER OR SKID MOUNTED TRASH PUMP (MQ600TD)

Construction:

Front case	30 grey iron
Impeller	SG cast iron
Volute	SG cast iron
Back plate	30 grey iron
Mechanical seal	Oil lubricated tungsten titanium carbide
Outlet	30 grey iron
Casing bolts	high tensile steel
Yoke bolts	high tensile steel
Check valve	moulded neoprene with steel reinforcement

Dimensions:

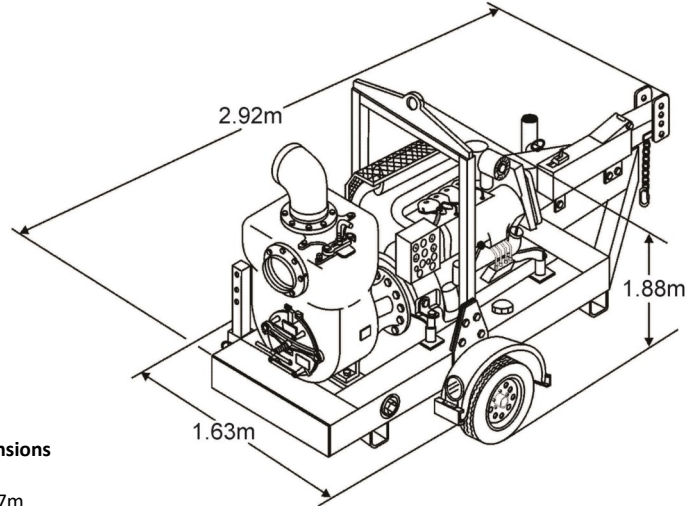

Model	Engine	Type	PSI	Max Head (m)	Max Flow (lpm)	Suction Port	Discharge Port	Self primes to (m)	RPM	Weight (kg)
MQ600TD Skid mounted	Deutz F4L914	80HP Diesel Electric Start	65	46	6,000	6"	6"	7.6	1900	960
MQ600TD Trailer mounted										1111

Noise level of the engine at 7 metres from unit, based on an average of four readings, with no load at 1900 rpm is 75dBA & 77.05dBA at full load.

Performance Curve



Aussie Mine Spec Option:

- includes
- Emergency stop
 - Muffler protection cage
 - Fire extinguisher
 - Operation warning light
 - Battery isolation

Due to our program of continuous product development the manufacturer reserves the right to alter specifications without notice.