

Mono[®]

National Oilwell Varco

G60 Grifter[®] Macerating Sewage Pump

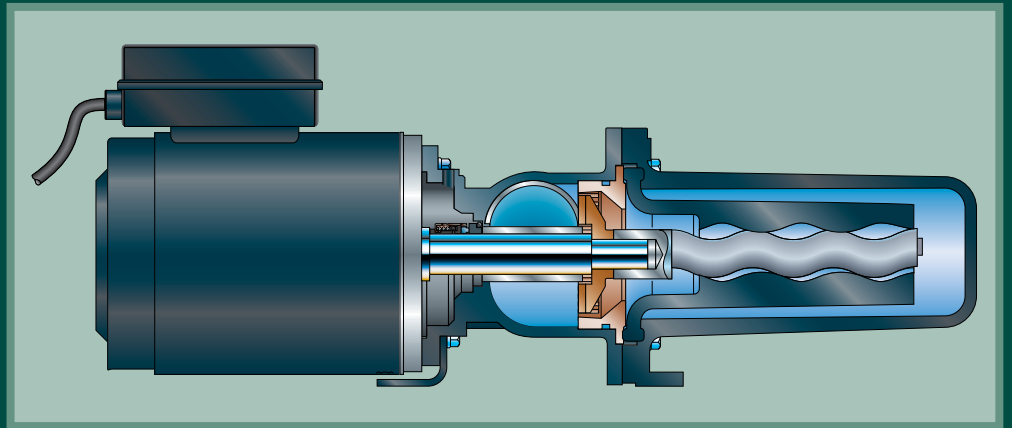

**Australian Designed
& Manufactured**

NOV Mono[®]

One Company, Unlimited Solutions

Mono[®] G60 Grifter[®] for Macerating

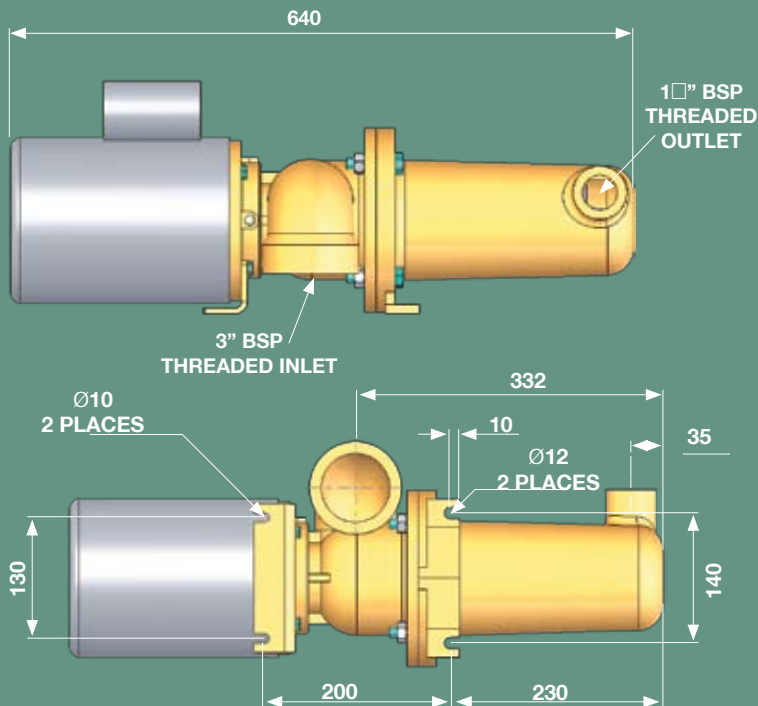

Tough Efficient Shredding Action

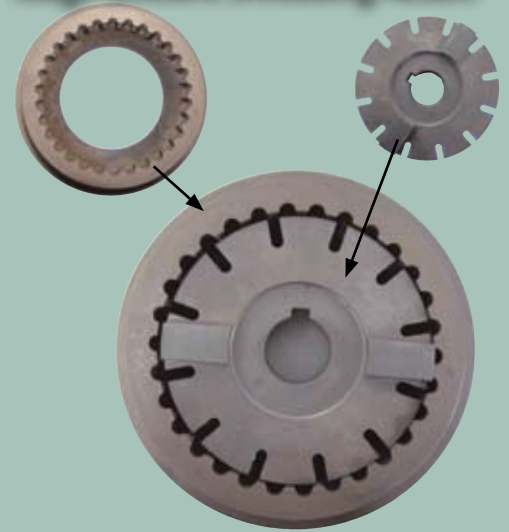

Hardened tool steel cutter with Bi-Hammers for smashing. Grooved chromium iron cutter ring for shredding solids.

Features	Benefits
Simplicity of Design	<ul style="list-style-type: none"> Ease of maintenance.
Compact Unit	<ul style="list-style-type: none"> Easy to handle.
Can be mounted above ground or in below ground dry enclosure	<ul style="list-style-type: none"> Reduce risk of sewage spill or contamination. Less health risks. Easy access for maintenance. Safer operation.
Integral Macerating Device	<ul style="list-style-type: none"> Efficient shredding & cutting of solids. Smaller particle size eliminates blockages. Smaller diameter discharge pipe. Reduced risk of septicity & odours.
Shroud/Flow Deflection	<ul style="list-style-type: none"> No dead spots for solids build up. More aggressive shearing action. Cleaner pump.
Large Inlet (Elutriating Pipe)	<ul style="list-style-type: none"> Eliminate heavy solids entering pump. Reduce blockage. Longer pump life.
Small bore discharge pipe rather than conventional gravity/rising main	<ul style="list-style-type: none"> Reduced installation costs.
Low Speed	<ul style="list-style-type: none"> Longer pump life. Reduce wear and maintenance cost. Lower power consumption.
Mechanical Seal - Oil Bath	<ul style="list-style-type: none"> Reduced risk of damage. Longer pump life.
High Efficiency	<ul style="list-style-type: none"> Lower running costs.

The Grifter shifts sewage to sewer mains from:

Single residential dwellings
Hotel - Motel complexes
Sporting complexes
Recreational facilities
Shopping centres

Residential sub-division developments
Public utility establishments
Schools
Industrial - Commercial complexes
Rural sites

Marinas
Construction - Mine accommodation sites
Ships and barges
Caravan Parks, camping areas.

erating & Pumping Sewage

Mono G60 Grifter - Efficient Pump and integral Macerator Unit

Build:

Pump - Mono progressive cavity featuring corrosion resistant body, stainless steel rotating parts with a mechanical seal.

Macerator - Hardened tool steel "Bi-Hammer" dished macerator cutter fully integrated.

Motor - Close coupled 4 pole 0.95 kW 240 volt for domestic power supply. (Optional 415 volt)

Function:

Self priming, elutriating action allows sewage to travel up the suction pipe and into the pump chamber while heavy objects fall to the bottom of the tank.

Bi-Hammer Macerator smashes and shears the sewage solids into a slurry of small particles.

Progressive cavity pump transports the sewage under pressure to it's destination.

Resultant Cost Savings:

Small particles - small diameter discharge pipe minimum 32mm rather than minimum 80mm, if sewage unmacerated - saving on material and installation costs.

Pressurised Sewer - pipes laid as shallow pressure mains rather than deeper graded gravity mains - saving on installation and disruption.

High pressure capability (60m) - access to elevated or distant points without the need for intermediate pumping stations.

Lower speed, higher efficiency, lower wear rates when compared to submersible units.

Easier and faster access and maintenance to on-ground or dry well unit.

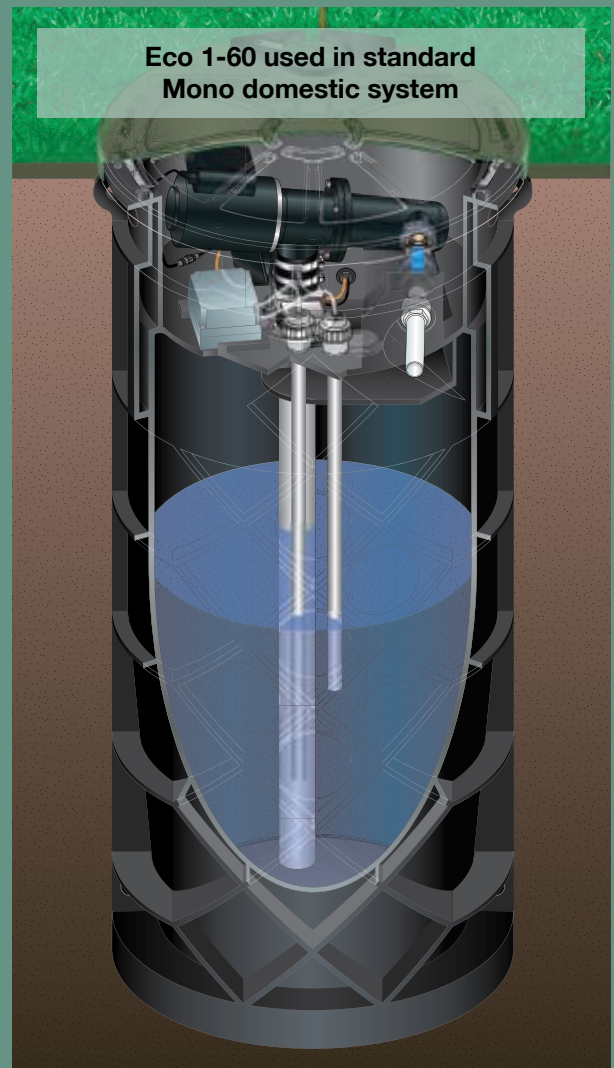

Performance Curve

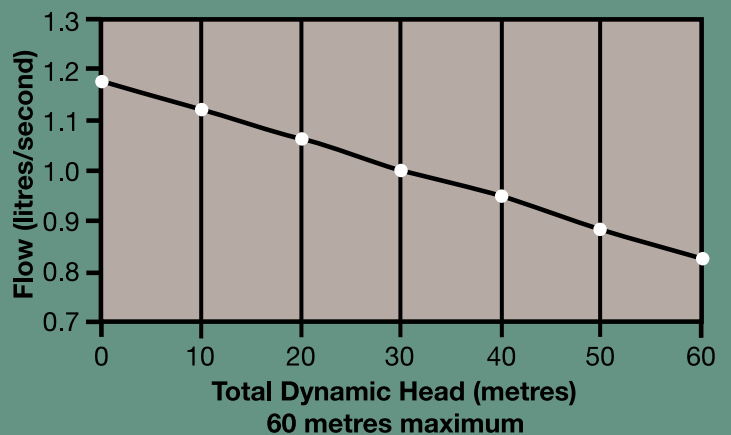

Total head from all causes - Maximum suction lift 4m

Motor Size	Port Size	10m	20m	30m	40m	50m	60m
0.93kW - 1.2HP	Outlet 1¼" BSP Female Inlet 3" BSP Female	1.13 lps	1.05 lps	1.01 lps	0.97 lps	0.90 lps	0.83 lps

Mono Pumps Around the World

Europe

Mono Pumps Ltd, Martin Street, Audenshaw
Manchester, M34 5JA, England
T. +44 161 339 9000
E. info@mono-pumps.com

D.M.I EST, 56, rue du Pont
88300 Rebeuville, France
T. +33 3 29 94 26 88
E. dmi-est@dmi-est.fr

Americas

Monoflo Inc., 10529 Fisher Road
Houston, Texas 77041, USA
T. +1 713 980 8400
E. monoflo@nov.com

Monoflo S.A., Ing Huergo 2239
(1842) Monte Grande
Pcia. de Buenos Aires, Argentina
T. +54 11 4290 9940/50
E. info.monoflo@nov.com.ar

Monoflo Canada, 6010 – 53rd Ave
Alberta, Lloydminster
T9V2T2, Canada
T. + 1 780 875 5584
E: info.monoflo@nov.com

Asia

Mono Pumps Ltd, Building 5,
Madong Industrial Park, 1250 Sicheng Rd
Malu Town, Jiading District, Shanghai 201801
T. +86 21 3990 4588
E. monoshanghai@nov.com

Australasia

Mono Pumps (Australia) Pty Ltd
338-348 Lower Dandenong Road
Mordialloc, Victoria 3195, Australia
T. 1800 333 138
E. ozsales@mono-pumps.com

Mono Pumps (New Zealand) Ltd
35-41 Fremlin Place, Avondale
Auckland, 1026, New Zealand
T. +64 9 829 0333
E. info@mono-pumps.co.nz

Melbourne	T.	03 9580 5211	F.	03 9580 6659
Sydney	T.	02 8536 0900	F.	02 9542 3649
Brisbane	T.	07 3350 4582	F.	07 3350 3750
Adelaide	T.	08 8447 8333	F.	08 8447 8373
Perth	T.	08 9303 0444	F.	08 9303 4430
Darwin	T.	08 8931 3300	F.	08 8931 3200
Kalgoorlie	T.	08 9022 4880	F.	08 9022 3660
Christchurch NZ	T.	+64 3 341 8379	F.	+64 3 341 8486

www.monopumps.com



© Mono Pumps Limited September 2010 Literature reference: ART08-1

Published information other than that marked CERTIFIED does not extend any warranty or representation, expressed or implied, regarding these products. Any such warranties or other terms and conditions of sales and products shall be in accordance with Mono Pumps Limited standard terms and conditions of sale, available on request.

Mono® is a registered trademark of Mono Pumps Ltd.

Registered in England No 300721



One Company, Unlimited Solutions