

Qty.	Description
------	-------------

1	MAGNA3 50-180 F
---	-----------------



Note! Product picture may differ from actual product

Product No.: [97924286](#)

The Grundfos MAGNA3 is a circulator pump with permanent magnet motor that will fit both heating, cooling and domestic hot water circulation applications perfectly, making it the obvious choice for almost any building project – old or new.

With its unrivalled efficiency, all-encompassing range and built-in communication capabilities plus functionalities replacing system components, the MAGNA3 is ideal for building owners, engineers and specifiers looking to create high-performance systems for buildings.

The MAGNA3 is a canned-rotor type, i.e. pump and motor form an integral unit without shaft seal and with only two gaskets for sealing. The bearings are lubricated by the pumped liquid.

The innovative clamp with only one screw enables easy repositioning of the pump head.

The MAGNA3 is a pump with no maintenance requirements and with extremely low Life Cycle Cost.

97924286 MAGNA3 50-180 F

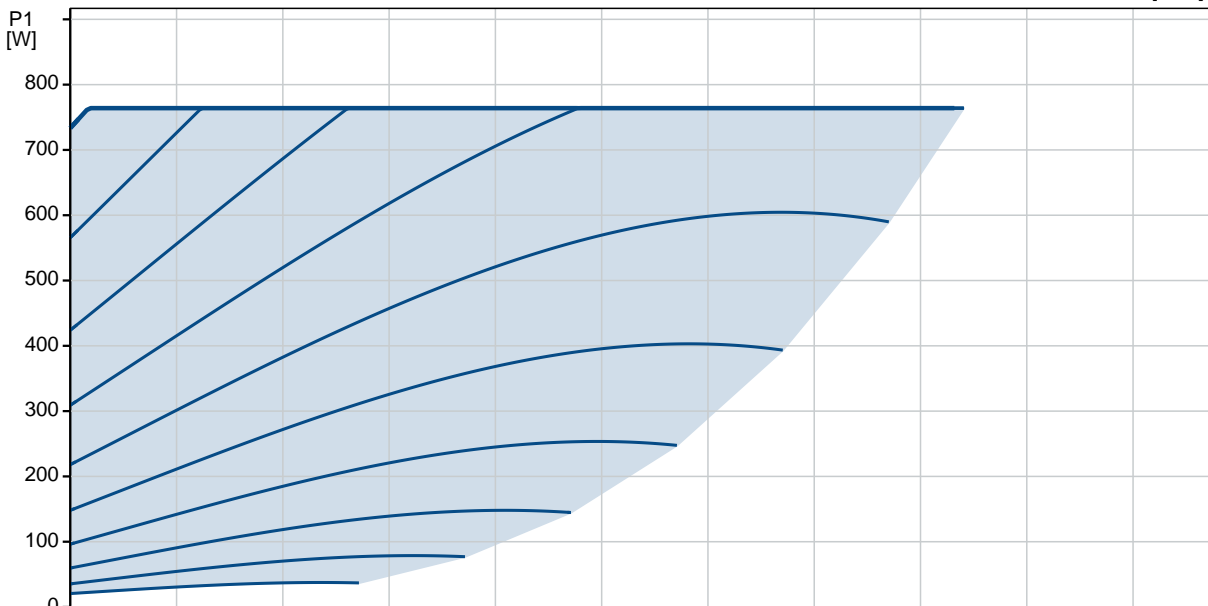
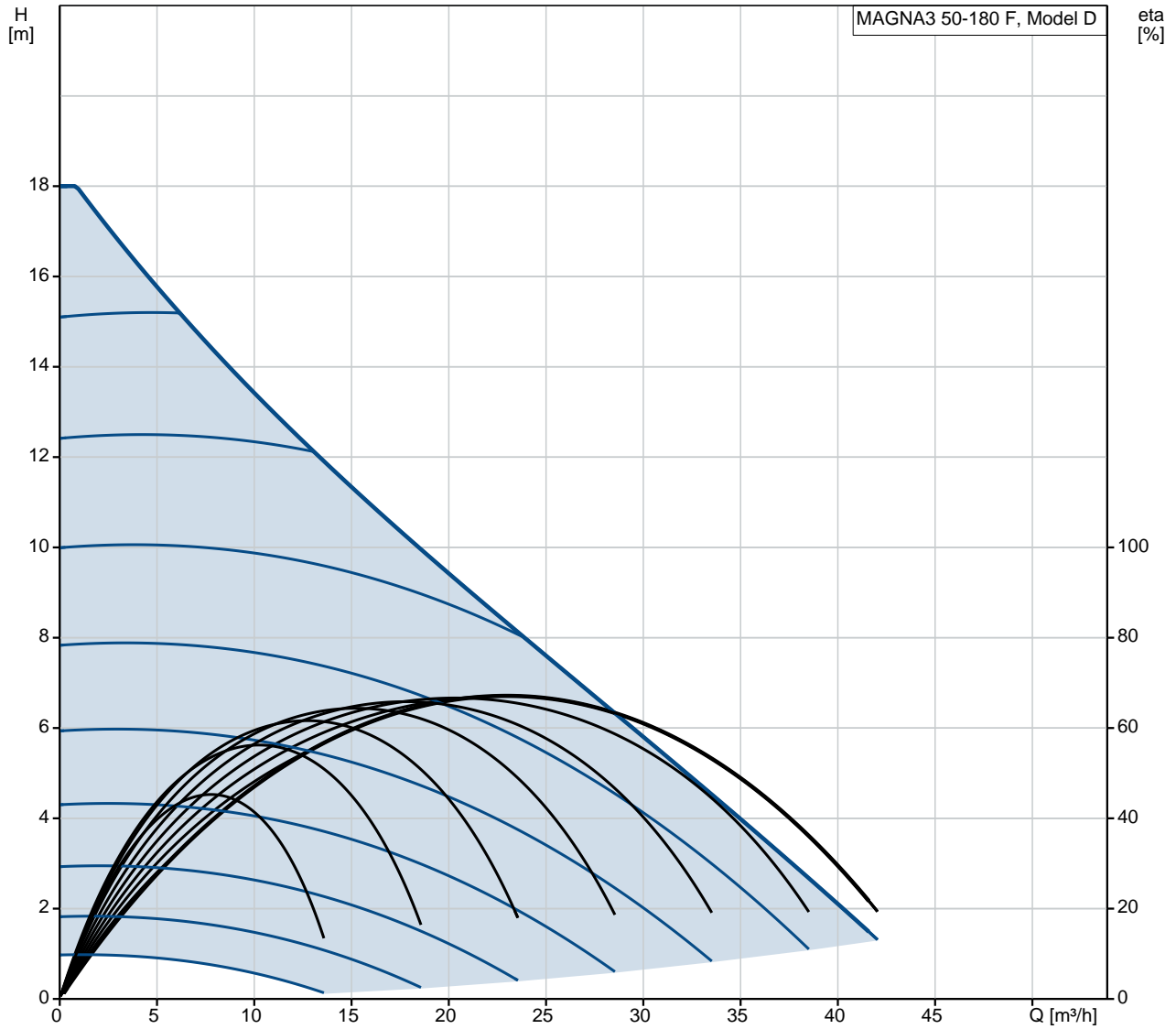

Description	Value
General information:	
Product name:	MAGNA3 50-180 F
Product No:	97924286
EAN number:	5710626493616
	5710626493616
Technical:	
Rated flow:	21.88 m ³ /h
Rated head:	8.733 m
Head max:	180 dm
TF class:	110
Approvals on nameplate:	CE, VDE, EAC, CN ROHS, WEEE
Model:	D
Materials:	
Pump housing:	Cast iron
	EN-GJL-250
	ASTM A48-250B
Impeller:	PES 30%GF
Installation:	
Range of ambient temperature:	0 .. 40 °C
Maximum operating pressure:	10 bar
Flange standard:	DIN
Pipe connection:	DN 50
Pressure rating:	PN6/10
Port-to-port length:	280 mm
Liquid:	
Pumped liquid:	Water
Liquid temperature range:	-10 .. 110 °C
Selected liquid temperature:	60 °C
Density:	983.2 kg/m ³
Electrical data:	
Power input - P1:	23 .. 764 W
Mains frequency:	50 / 60 Hz
Rated voltage:	1 x 230 V
Maximum current consumption:	0.24 .. 3.45 A
Enclosure class (IEC 34-5):	X4D
Insulation class (IEC 85):	F
Others:	
Energy (EEI):	0.18
Net weight:	19 kg
Gross weight:	21.2 kg
Shipping volume:	0.046 m ³
Danish VVS No.:	380953518
Swedish RSK No.:	5732498
Finnish LVI No.:	4615157
Norwegian NRF no.:	9042677

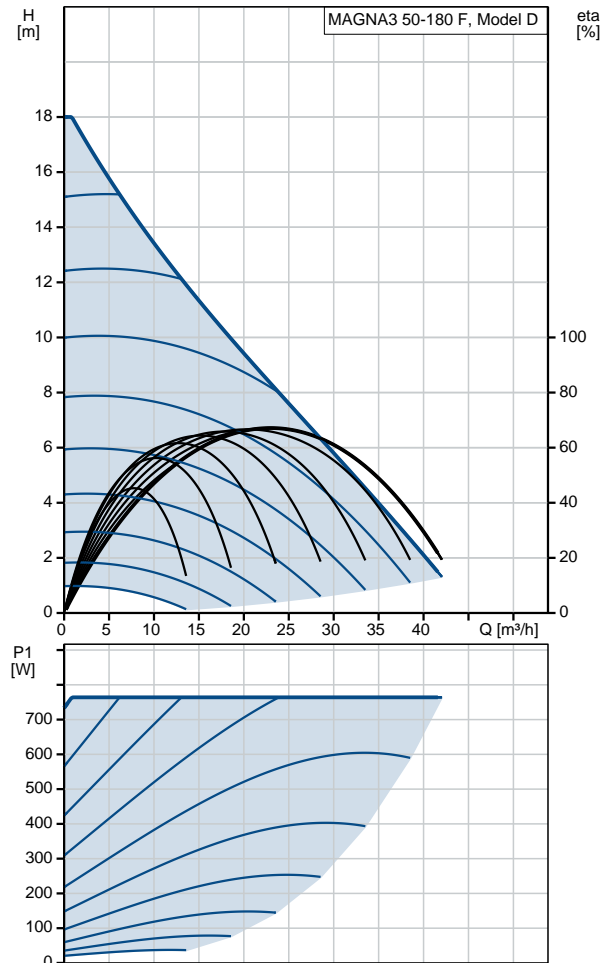

97924286 MAGNA3 50-180 F

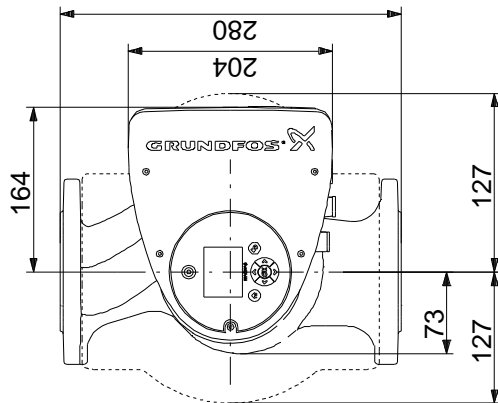
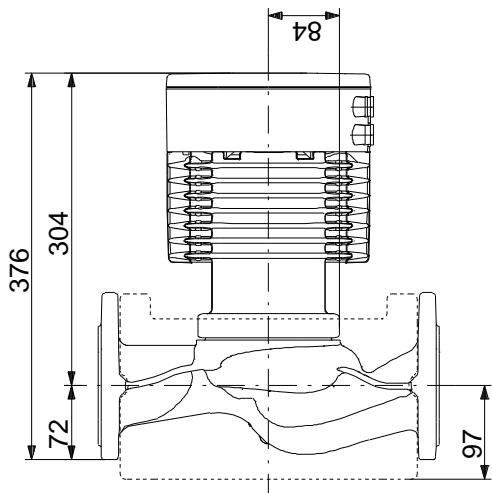
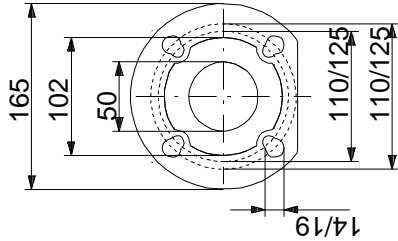

Note! All units are in [mm] unless others are stated.
Disclaimer: This simplified dimensional drawing does not show all details.