

Submersible Electric Pumps for drainage of dirty water

DOMO Series

The DOMO series electric pumps are available with **twin-channel** or **vortex** impeller (DOMO VX). Designed to handle liquids with suspended solids up to 50 mm in diameter (35 mm for DOMO 7 and DOMO 7VX).

Four basic models with 0,55 to 1,5 kW.

DRIVELUB SEAL SYSTEM.



APPLICATIONS

- Pumping of effluent (VX model handles also suspended filaments).
- Emptying of septic tanks and residential sumps.
- Draining of flooded basements and garages.

SPECIFICATIONS

- **Maximum liquid temperature:** 35°C with fully submerged pump.
- **Dry motor.**
- **Power cord: H07RN-F**
 - single-phase: with plug.
 - three-phase: without plug.
- **Insulation class 155°C (F).**
- **IPX8 protection.**
- **Maximum immersion depth:** 5 m.
- **Versions:**
 - Single-phase: 220-240V, 50Hz 2 poles.
 - Three-phase: 220-240V, 50Hz 2 poles. 380-415V, 50Hz 2 poles.
- **Motor power:**
 - single-phase: **0,55 to 1,1 kW.**
 - three-phase: **0,55 to 1,5 kW.**
- **The single-phase versions feature:**
 - **pre-assembled float switch** for automatic pump operation.
 - **built-in capacitor.**
 - **thermal overload protection** to stop pump supply in case of overheating.
- The **DOMO 7** and **DOMO 7VX** models feature:
 - **Rp 1 1/2 threaded delivery port** (female gas).
 - handling of liquids with suspended **solids up to 35 mm** in diameter.
 - **fiberglass-reinforced technopolymer impeller** (DOMO S7 and DOMO S7VX models with stainless steel impeller are also available).
- The **DOMO 10-15-20** and **DOMO 10-15-20 VX** models feature:
 - **Rp 2" threaded delivery port** female gas (can be turned into a flanged version if an optional accessory is installed).
 - handling of liquids with suspended **solids up to 50 mm** in diameter.
 - **stainless steel twin-channel or vortex impeller.**
- **DRIVELUB SEAL SYSTEM**
 - Watertight electric motor protected by multiple seal system with **oil chamber**. A **V-ring** and **silicon carbide mechanical seal** (extremely resistant to wear and abrasion), as well as a **lip seal** which is continuously lubricated by the **DRIVELUB system**, provide an extreme barrier against infiltration.

Submersible Electric Pumps for drainage of dirty water equipped with grinder system

DOMO GRI Series



The DOMO GRI series electric pumps are equipped with an extremely efficient and highly reliable grinder system.

The grinder is able to macerate all the solids present in the sewage and to pass it through small discharge pipes (25 mm diameter). DOMO GRI is available in the 1,1 kW and 1,5 kW power.

DRIVELUB SEAL SYSTEM.

APPLICATIONS

- Pumping of sewage with suspended solids.
- Emptying of septic tanks and residential sumps.
- Draining of flooded areas.
- Pumping water from a pressurized sewer network.

SPECIFICATIONS

- **Maximum liquid temperature:** 35°C with fully submerged pump.
- **Dry motor.**
- **Power cord: H07RN-F**
 - single-phase: with plug.
 - three-phase: without plug.
- **Insulation class 155°C (F).**
 - **IPX8 protection.**
 - **Maximum immersion depth: 5 m.**
 - **Versions:**
 - Single-phase: 220-240V, 50Hz 2 poles.
 - Three-phase: 220-240V, 50Hz 2 poles. 380-415V, 50Hz 2 poles.
- **Motor power:**
 - **1,1 kW** single-phase and three-phase.
 - **1,5 kW** single-phase and three-phase.
- **The single-phase versions** feature:
 - **pre-assembled float switch** for automatic pump operation.
 - **built-in capacitor (only for 1,1 kW).**
 - **thermo-amperometric overload protection** to stop pump supply in case of overheating.
- **DOMO GRI** pumps feature:
 - **Rp 1" threaded delivery port (female gas)** for 1,1kW (11/A).
 - **Rp 1"1/4 threaded delivery port (female gas)** for 1,1kW (11/HF) and 1,5kW (15).
 - technopolymer PBT **Impeller.**
 - high resistance stainless steel **grinder.**

DRIVELUB SEAL SYSTEM

- Watertight electric motor protected by multiple seal system with **oil chamber**. A **V-ring** and **silicon carbide mechanical seal** (extremely resistant to wear and abrasion), as well as a **lip seal** which is continuously lubricated by the **DRIVELUB system**, provide an extreme barrier against infiltration.

DOMO SERIES IDENTIFICATION CODE

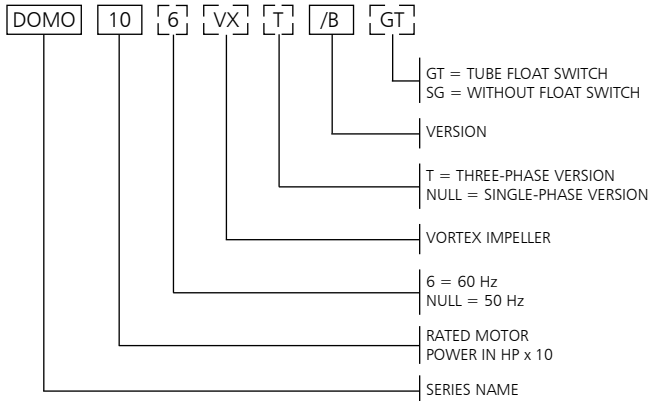

EXAMPLE : DOMO 10/B
 DOMO Series Electric pump, rated motor power 1 HP, 50 Hz version, single-phase, /B version.

DOMO GRI SERIES IDENTIFICATION CODE

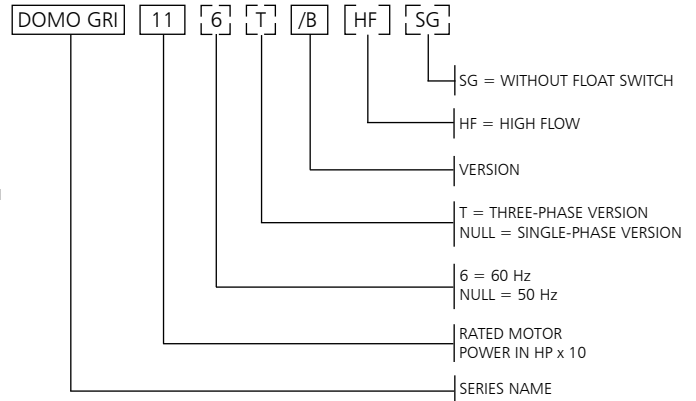

EXAMPLE : DOMO GRI 11
 DOMO GRI (grinder) Series Electric pump, rated motor power 1,1 kW, 50 Hz version, single-phase.

SINGLE-PHASE RATING PLATE

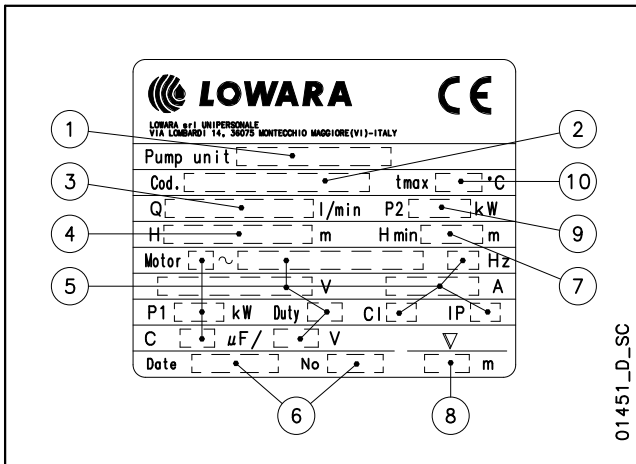

01451_D_SC

LEGEND

- 1 - Electric pump type
- 2 - Code
- 3 - Delivery range
- 4 - Head range
- 5 - Motor type
- 6 - Date of manufacture and serial number
- 7 - Minimum head
- 8 - Maximum immersion depth
- 9 - Rated output
- 10 - Maximum liquid temperature

THREE-PHASE RATING PLATE

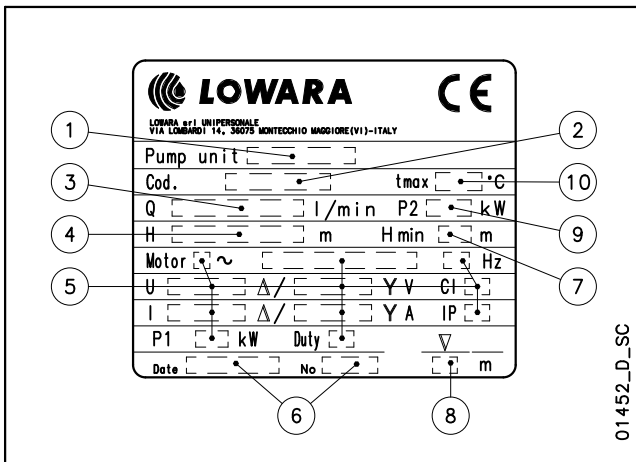

01452_D_SC

DOMO SERIES TABLE OF MATERIALS

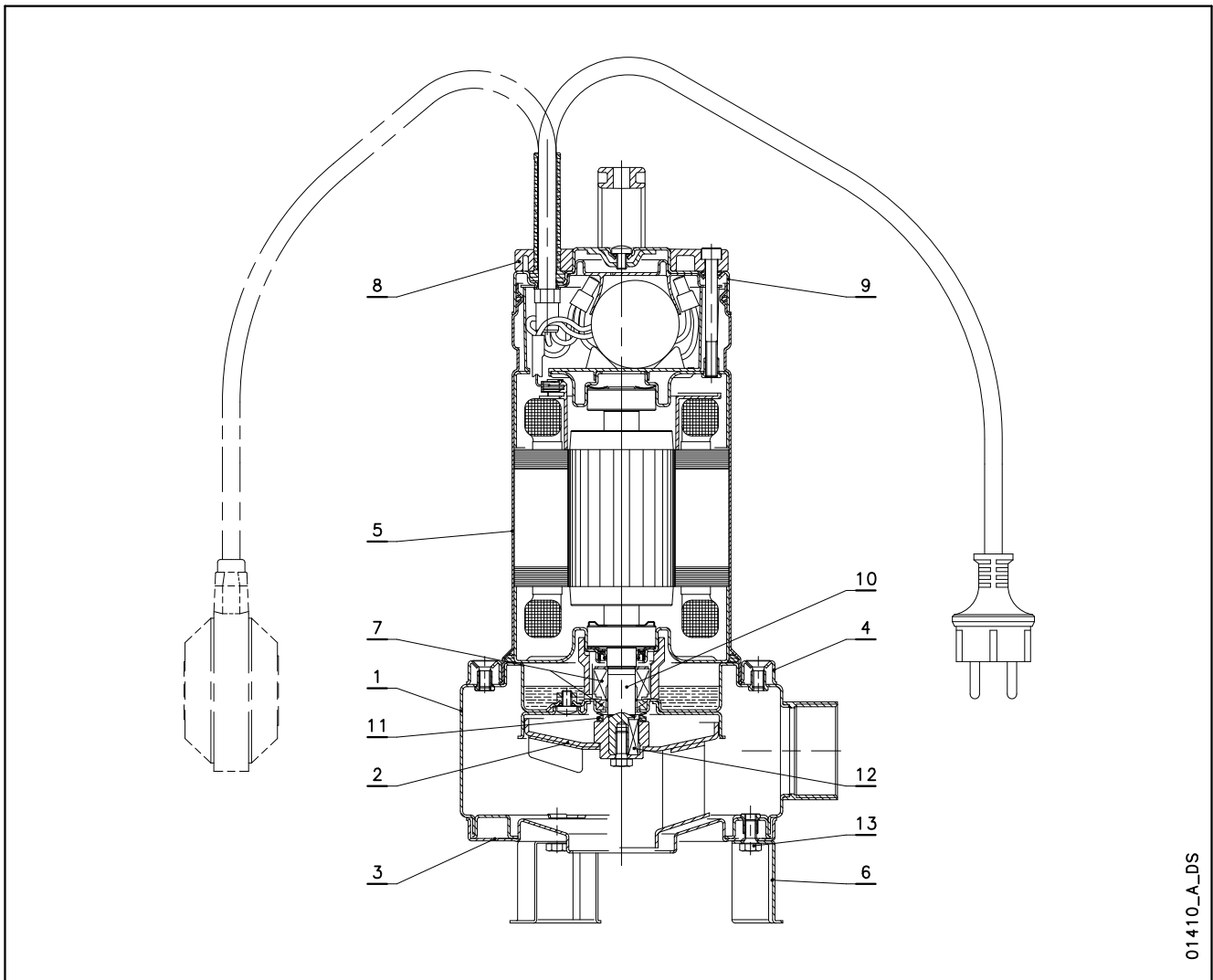

01410_A_DS

REF. N.	NAME	MATERIAL	REFERENCE STANDARDS	
			EUROPE	USA
1	Pump body	Stainless steel	EN 10088-1-X5CrNi18-10 (1.4301)	AISI 304
2	Impeller	PA 66 + 30 % GF		
		Stainless steel	EN 10088-1-X5CrNi18-10 (1.4301)	AISI 304
3	Suction flange	Stainless steel	EN 10088-1-X5CrNi18-10 (1.4301)	AISI 304
4	Fixing ring	Stainless steel	EN 10088-1-X5CrNi18-10 (1.4301)	AISI 304
5	Motor casing	Stainless steel	EN 10088-1-X5CrNi18-10 (1.4301)	AISI 304
6	Support foot	Stainless steel	EN 10088-1-X5CrNi18-10 (1.4301)	AISI 304
7	Mechanical seal	Silicon carbide / Silicon carbide / NBR (standard version)		
8	Handle	PA 66 + 30 % GF		
9	Upper cover	Stainless steel	EN 10088-1-X5CrNi18-10 (1.4301)	AISI 304
10	Shaft end	Stainless steel	EN 10088-1-X5CrNi18-10 (1.4301)	AISI 304
11	Elastomers	NBR (standard version)		
12	Key	Stainless steel	EN 10088-1-X5CrNiMo17-12-2 (1.4401)	AISI 316
13	Screws	Stainless steel	EN 10088-1-X5CrNi18-10 (1.4301)	AISI 304

domo-en_b_tm

DOMO GRI SERIES TABLE OF MATERIALS

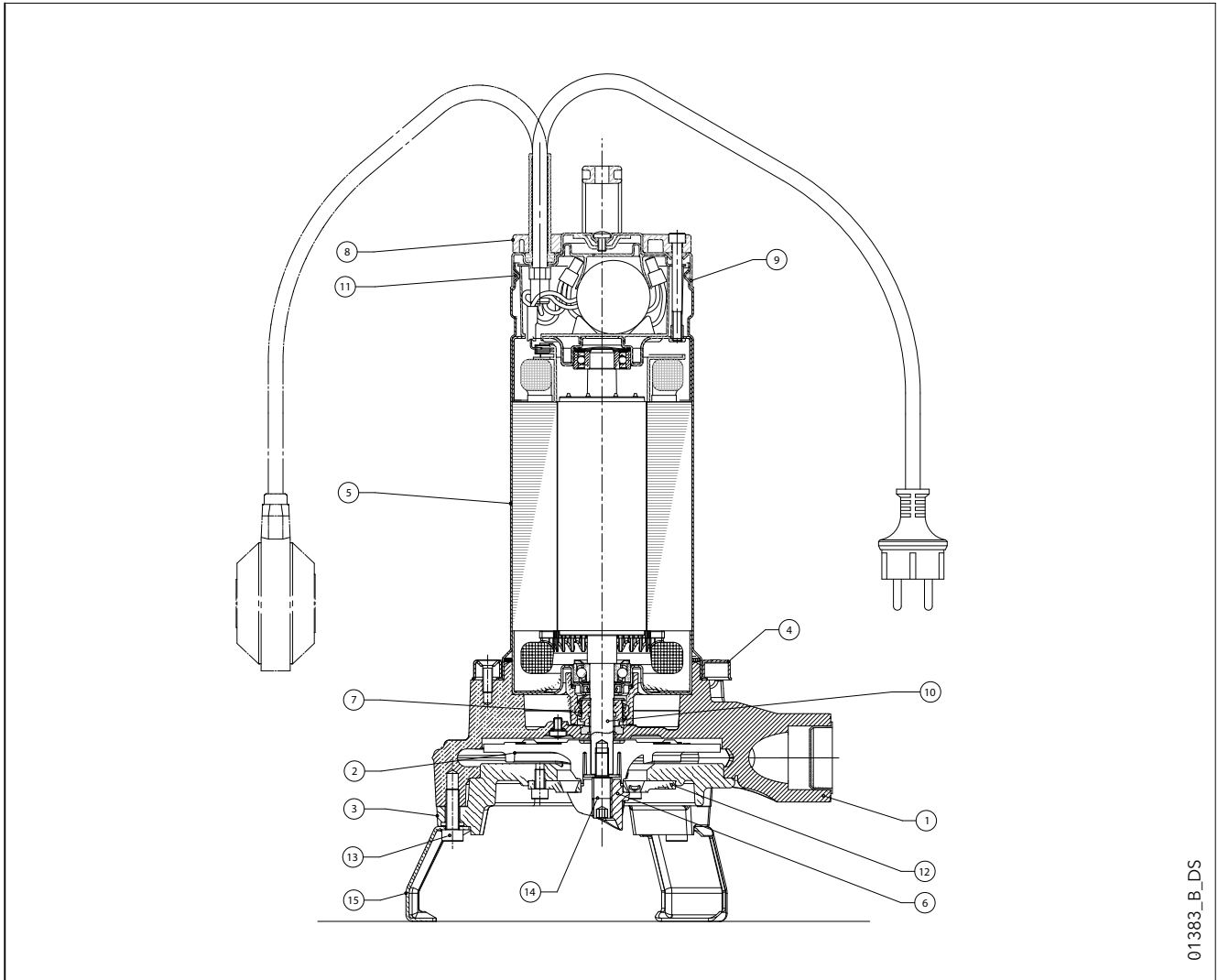

01383_B_DS

REF. N.	NAME	MATERIAL	REFERENCE STANDARDS	
			EUROPE	USA
1	Pump body	Cast iron	EN 1561-GJL-200 (JL1030)	ASTM Class 30
2	Impeller	PBT		
3	Suction cover	Cast iron	EN 1561-GJL-200 (JL103)	ASTM Class 30
4	Fixing ring	Stainless steel	EN 10088-1-X5CrNi18-10 (1.4301)	AISI 304
5	Motor casing	Stainless steel	EN 10088-1-X5CrNi18-10 (1.4301)	AISI 304
6	Cutter wheel	Stainless steel	X95CrMoV17 (DIN 1.4535)	-
7	Mechanical seal	Silicon carbide / Silicon carbide / NBR (standard version)		
8	Handle	PA 66 + 30 % GF		
9	Upper cover	Stainless steel	EN 10088-1-X5CrNi18-10 (1.4301)	AISI 304
10	Shaft end	Stainless steel	EN 10088-1-X5CrNi18-10 (1.4301)	AISI 304
11	Elastomers	NBR (standard version)		
12	Cutter ring	Stainless steel	X95CrMoV17 (DIN 1.4535)	-
13	Screws	Stainless steel	EN 10088-1-X5CrNi18-10 (1.4301)	AISI 304
14	Impeller fixing screw + wheel	Stainless steel	EN 10088-1-X17CrNi16-2 (1.4057)	AISI 431
15	Support foot	Stainless steel	EN 10088-1-X5CrNi18-10 (1.4301)	AISI 304

domo-gri-en_d_tm

DOMO SERIES - DOMO GRI MECHANICAL SEAL

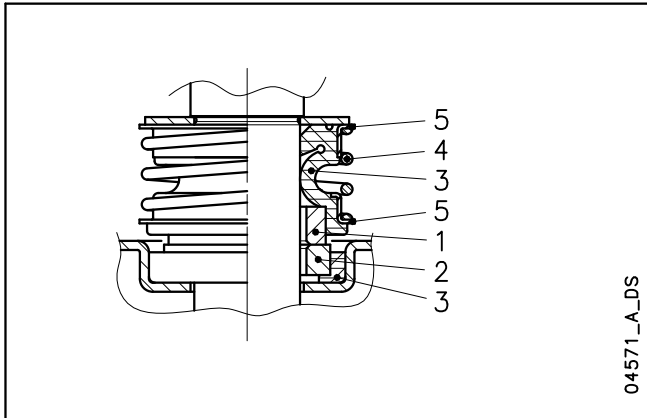

LIST OF MATERIALS

POSITION 1 - 2	POSITION 3	POSITION 4 - 5
Q1 : Silicon carbide	P : NBR	G : AISI 316
	V : FPM	

diwa_ten-mec-en_a_tm

SEAL TYPES

TYPE	POSITION					TEMPERATURE (°C)
	1 ROTATING ASSEMBLY	2 FIXED ASSEMBLY	3 ELASTOMERS	4 SPRINGS	5 OTHER COMPONENTS	
STANDARD MECHANICAL SEAL						
Q ₁ Q ₁ PGG	Q ₁	Q ₁	P	G	G	0 +35
OTHER MECHANICAL SEAL TYPES						
Q ₁ Q ₁ VGG	Q ₁	Q ₁	V	G	G	0 +35

domo_tipi-ten-mec-en_b_tc

DOMO SERIES OPERATING CHARACTERISTICS AT 50 Hz

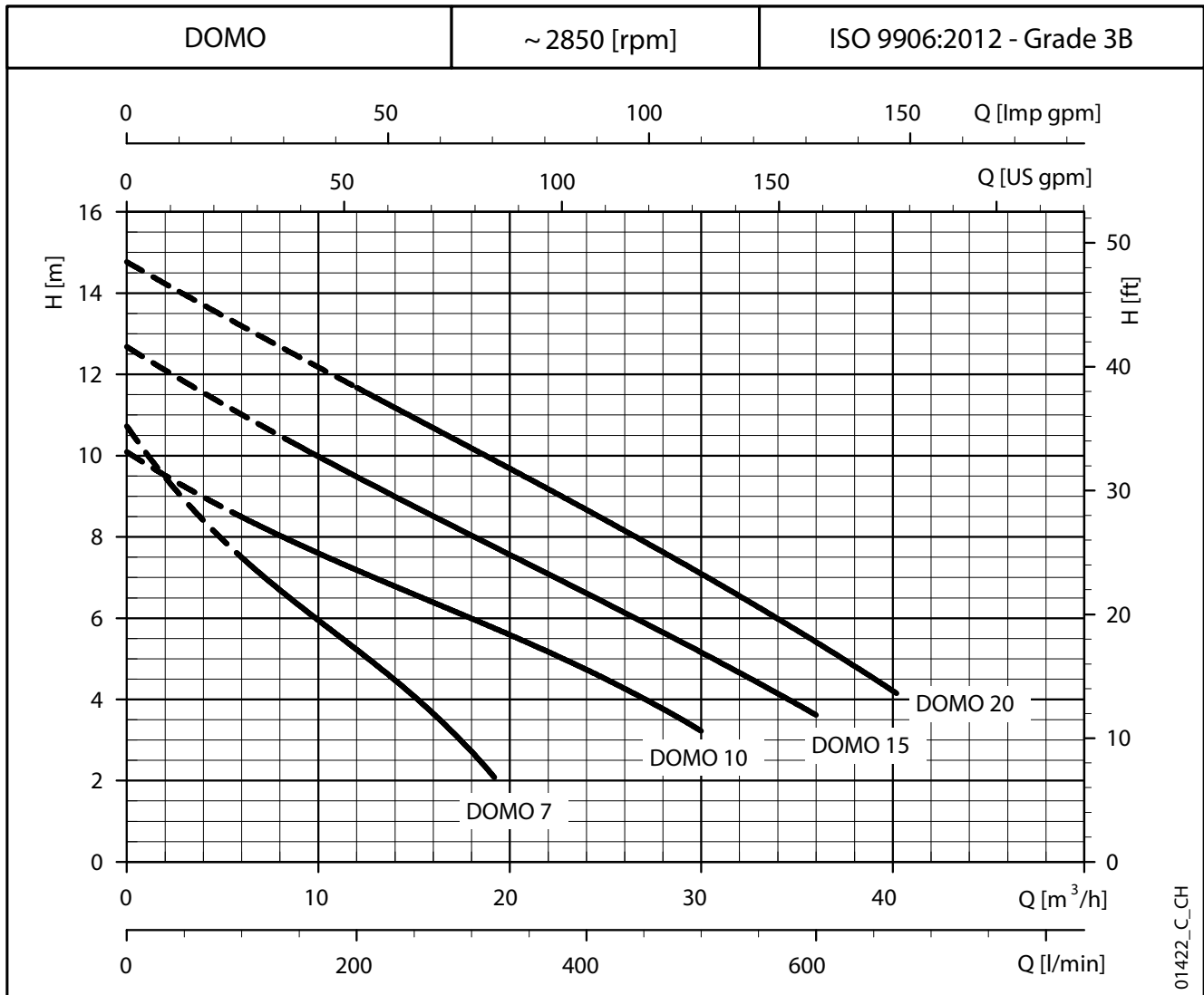

HYDRAULIC PERFORMANCE TABLE

PUMP TYPE	RATED POWER		Q = DELIVERY											
			H = TOTAL HEAD METRES COLUMN OF WATER											
			l/min	0	100	150	200	250	300	320	400	500	600	670
	kW	HP	m ³ /h	0	6	9	12	15	18	19,2	24	30	36	40,2
DOMO 7(T) - S7(T)	0,55	0,75	10,7	7,5	6,3	5,2	4,1	2,7	2,1					
DOMO 10(T)	0,75	1	10,1	8,5	7,8	7,2	6,6	6,0	5,8	4,7	3,2			
DOMO 15(T)	1,1	1,5	12,7	11,0	10,2	9,5	8,8	8,0	7,8	6,6	5,2	3,6		
DOMO 20T	1,5	2	14,8	13,2	12,4	11,7	10,9	10,2	9,9	8,7	7,1	5,4	4,2	

These performances are valid for liquids with density $\rho = 1,0 \text{ kg/dm}^3$ and kinematic viscosity $\nu = 1 \text{ mm}^2/\text{s}$.

domo-2p50-en_b_th

ELECTRICAL DATA TABLE

PUMP TYPE	ABSORBED POWER*	ABSORBED CURRENT*	CAPACITOR
SINGLE-PHASE	kW	220-240 V A	$\mu\text{F} / 450 \text{ V}$
DOMO 7 - (S7)	0,8 (0,76)	3,94 (3,83)	16
DOMO 10	1,14	5,84	22
DOMO 15	1,58	7,02	30
-	-	-	-

PUMP TYPE	ABSORBED POWER*	ABSORBED CURRENT*	ABSORBED CURRENT*
THREE-PHASE	kW	220-240 V A	380-415 V A
DOMO 7T - (S7T)	0,73 (0,68)	2,58	1,49
DOMO 10T	1,09	4,09	2,36
DOMO 15T	1,49	4,73	2,73
DOMO 20T	1,96	6,6	3,81

*Maximum values within operating range

domo-2p50-en_b_te

DOMO VX SERIES OPERATING CHARACTERISTICS AT 50 Hz

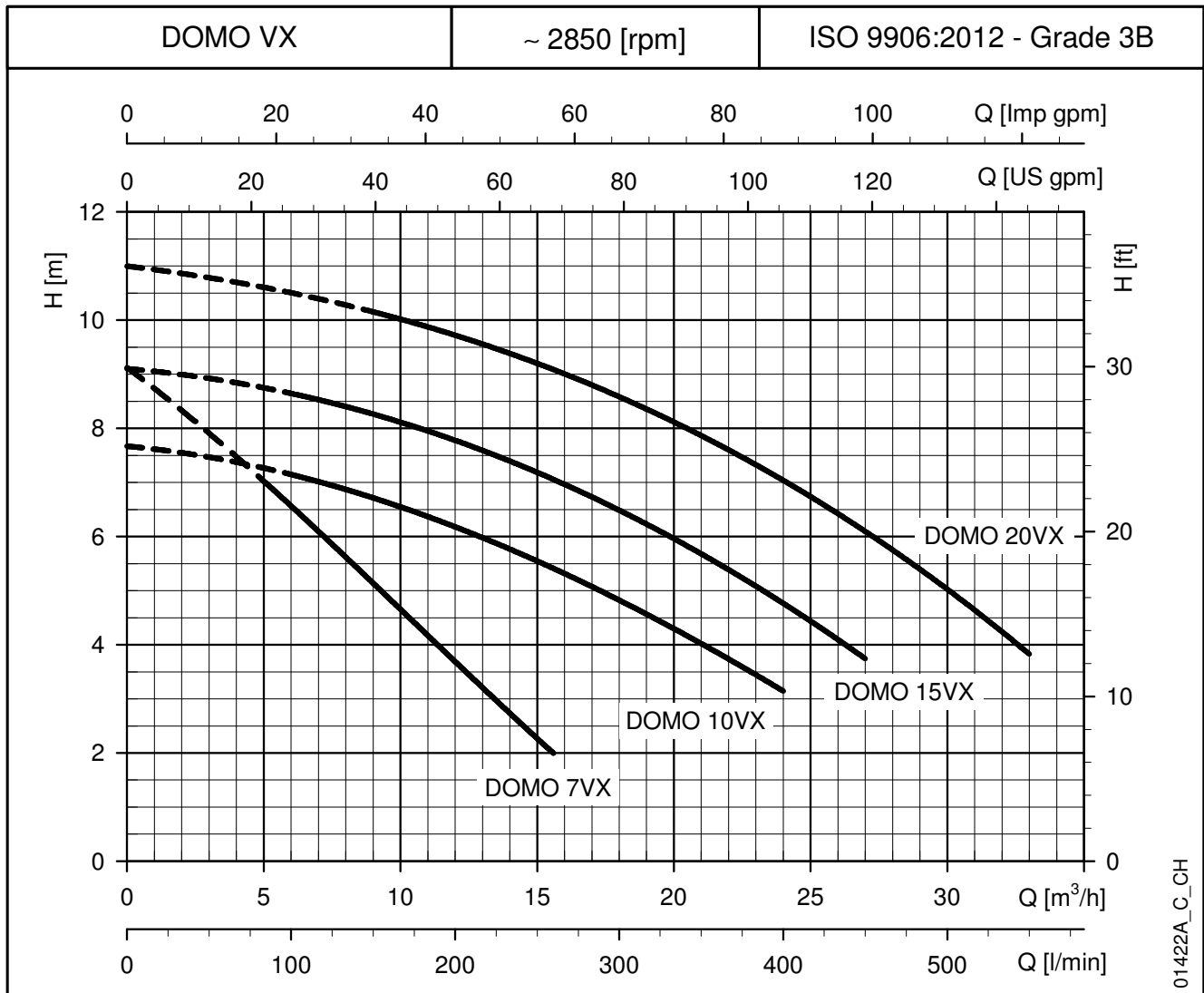

HYDRAULIC PERFORMANCE TABLE

PUMP TYPE	RATED POWER		Q = DELIVERY												
			H = TOTAL HEAD METRES COLUMN OF WATER												
			l/min	0	80	100	150	175	200	225	260	300	400	450	550
	kW	HP	m ³ /h	0	4,8	6	9	10,5	12	13,5	15,6	18	24	27	33
DOMO 7VX(T) - S7VX(T)	0,55	0,75	9,1	7,1	6,6	5,1	4,4	3,7	3,0	2,0					
DOMO 10VX(T)	0,75	1	7,7	7,3	7,1	6,7	6,5	6,2	5,9	5,4	4,8	3,1			
DOMO 15VX(T)	1,1	1,5	9,1	8,8	8,6	8,3	8,0	7,8	7,5	7,1	6,5	4,8	3,7		
DOMO 20VXT	1,5	2	11,0	10,6	10,5	10,2	9,9	9,7	9,5	9,1	8,6	7,0	6,1	3,8	

These performances are valid for liquids with density $\rho = 1,0 \text{ kg/dm}^3$ and kinematic viscosity $\nu = 1 \text{ mm}^2/\text{s}$.

domovx-2p50-en_b_th

ELECTRICAL DATA TABLE

PUMP TYPE	ABSORBED POWER*		CAPACITOR	PUMP TYPE	ABSORBED POWER*		ABSORBED CURRENT*
	SINGLE-PHASE				THREE-PHASE		
	kW	A	$\mu\text{F} / 450 \text{ V}$		kW	A	A
DOMO 7VX - (S7VX)	0,79 (0,83)	3,91 (4,03)	16	DOMO 7VXT - (S7VXT)	0,71 (0,76)	2,56 (2,63)	1,48 (1,52)
DOMO 10VX	1,15	5,88	22	DOMO 10VXT	1,10	4,09	2,36
DOMO 15VX	1,36	6,11	30	DOMO 15VXT	1,26	4,31	2,49
-	-	-	-	DOMO 20VXT	1,74	6,22	3,59

*Maximum values within operating range

domovx-2p50-en_b_te

DOMO GRI SERIES OPERATING CHARACTERISTICS AT 50 Hz

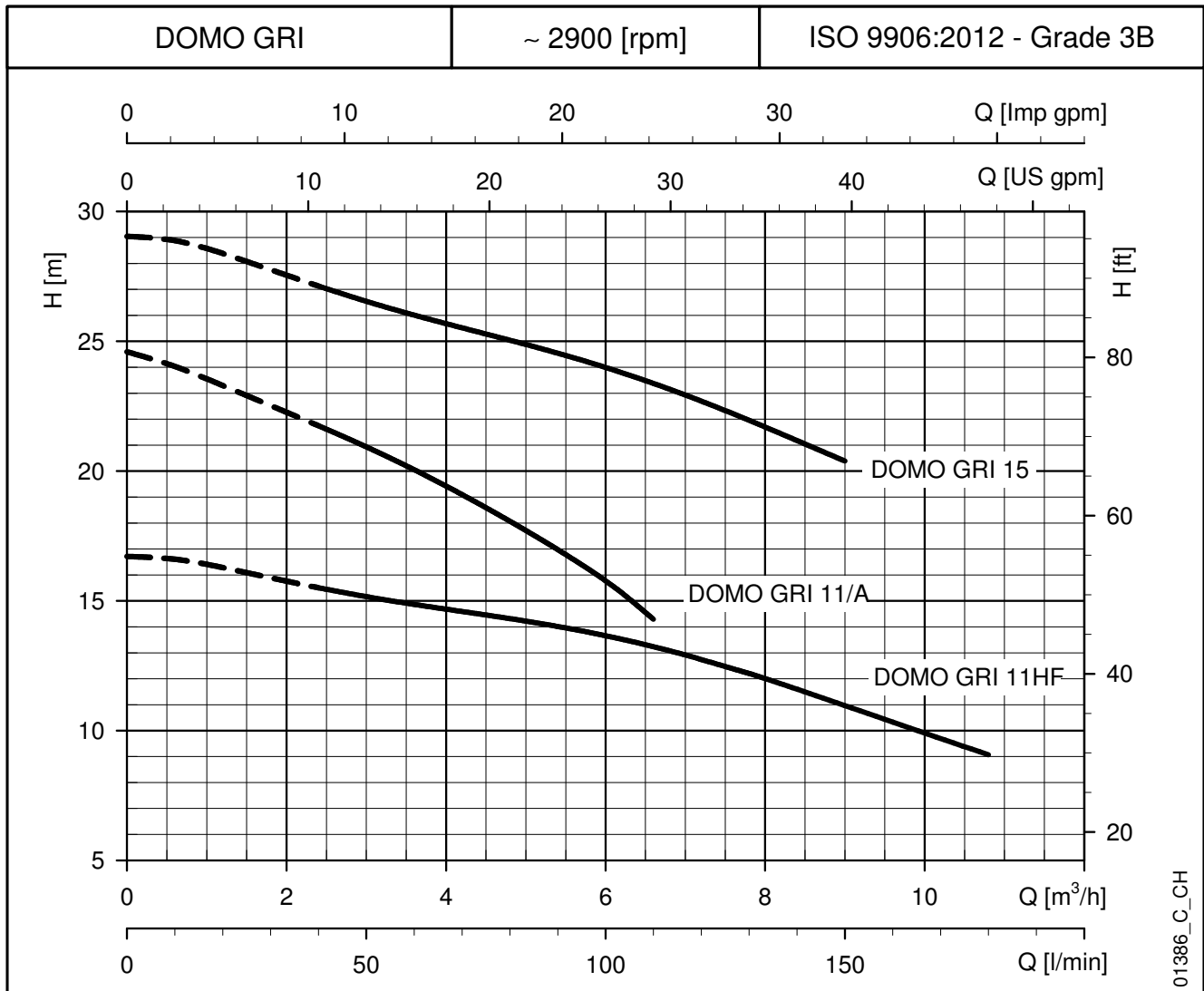

HYDRAULIC PERFORMANCE TABLE

PUMP TYPE	RATED POWER		Q = DELIVERY										
			l/s	0,7	0,9	1,1	1,7	1,9	2,2	2,4	2,6	2,8	3,0
		m³/h	2,4	3,2	3,9	6,2	7,0	7,7	8,5	9,3	10,0	10,8	
		H = TOTAL HEAD METRES COLUMN OF WATER											
	kW	HP											
DOMO GRI 11/A (SG)	1,1	1,5	24,6	21,7	20,7	19,5	15,3						
DOMO GRI 11T/A	1,1	1,5	24,6	21,7	20,7	19,5	15,3						
DOMO GRI 11 HF (SG)	1,1	1,5	16,7	15,5	15,1	14,7	13,5	12,9	12,3	11,5	10,7	9,9	9,1
DOMO GRI 11T HF	1,1	1,5	16,7	15,5	15,1	14,7	13,5	12,9	12,3	11,5	10,7	9,9	9,1
DOMO GRI 15 (SG)	1,5	2	29,0	27,1	26,4	25,7	23,8	23,0	22,0	21,0			
DOMO GRI 15T	1,5	2	29,0	27,1	26,4	25,7	23,8	23,0	22,0	21,0			

These performances are valid for liquids with density $\rho = 1,0 \text{ kg/dm}^3$ and kinematic viscosity $\nu = 1 \text{ mm}^2/\text{s}$.

domo-gri-2p50-en_c_th

ELECTRICAL DATA TABLE

PUMP TYPE	ABSORBED POWER*	ABSORBED CURRENT*	CAPACITOR	PUMP TYPE	ABSORBED POWER*	ABSORBED CURRENT*	ABSORBED CURRENT*
	SINGLE-PHASE				THREE-PHASE		
	kW	220-240 V A	$\mu\text{F} / 450 \text{ V}$		kW	220-240 V A	380-415 V A
DOMO GRI 11/A (SG)	1,20	5,41	30	DOMO GRI 11T/A	1,11	3,85	2,22
DOMO GRI 11HF	1,09	4,97	30	DOMO GRI 11T HF	0,96	3,81	2,20
DOMO GRI 15 (SG)	1,93	8,44	40	DOMO GRI 15T	1,57	5,94	3,43

* Maximum value in specified range

domo-gri-2p50-en_d_te

DOMO SERIES DIMENSIONS AND WEIGHTS

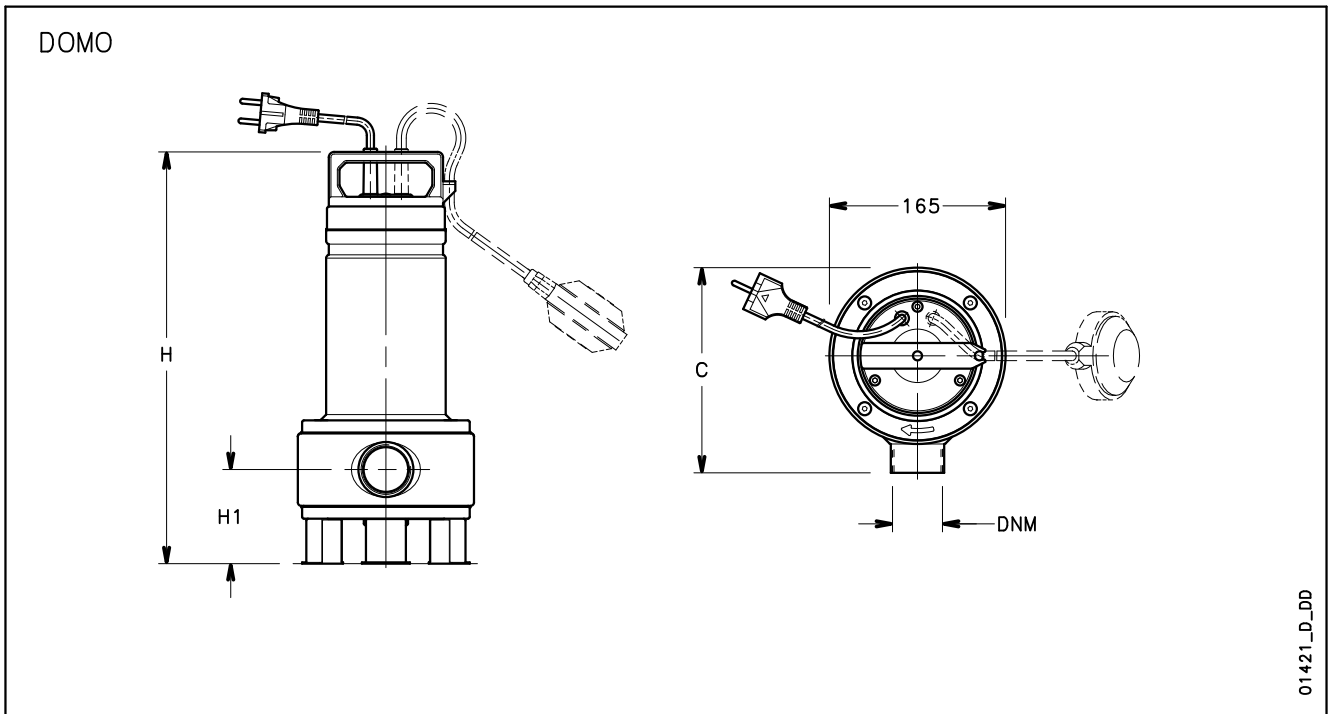

PUMP TYPE SINGLE-PHASE		DIMENSIONS (mm)			DNM	WEIGHT kg
		H	H1	C		
DOMO 7	DOMO 7 GT	391	88	193	Rp1½	10,2
DOMO 7VX	DOMO 7VX GT					
DOMO10	DOMO10 GT	468	111,5	198	Rp2	13,6
DOMO10VX	DOMO10VX GT					
DOMO15	DOMO15 GT	468	111,5	198	Rp2	15,3
DOMO15VX	DOMO15VX GT					
-	-	-	-	-	-	-

PUMP TYPE THREE-PHASE		DIMENSIONS (mm)			DNM	WEIGHT kg
		H	H1	C		
DOMO 7T	DOMO 7VXT	391	88	193	Rp1½	8,9
DOMO10T	DOMO10VXT					
DOMO15T	DOMO15VXT	468	111,5	198	Rp2	13,6
DOMO20T	DOMO20VXT					

domo-2p50-en_c_dd

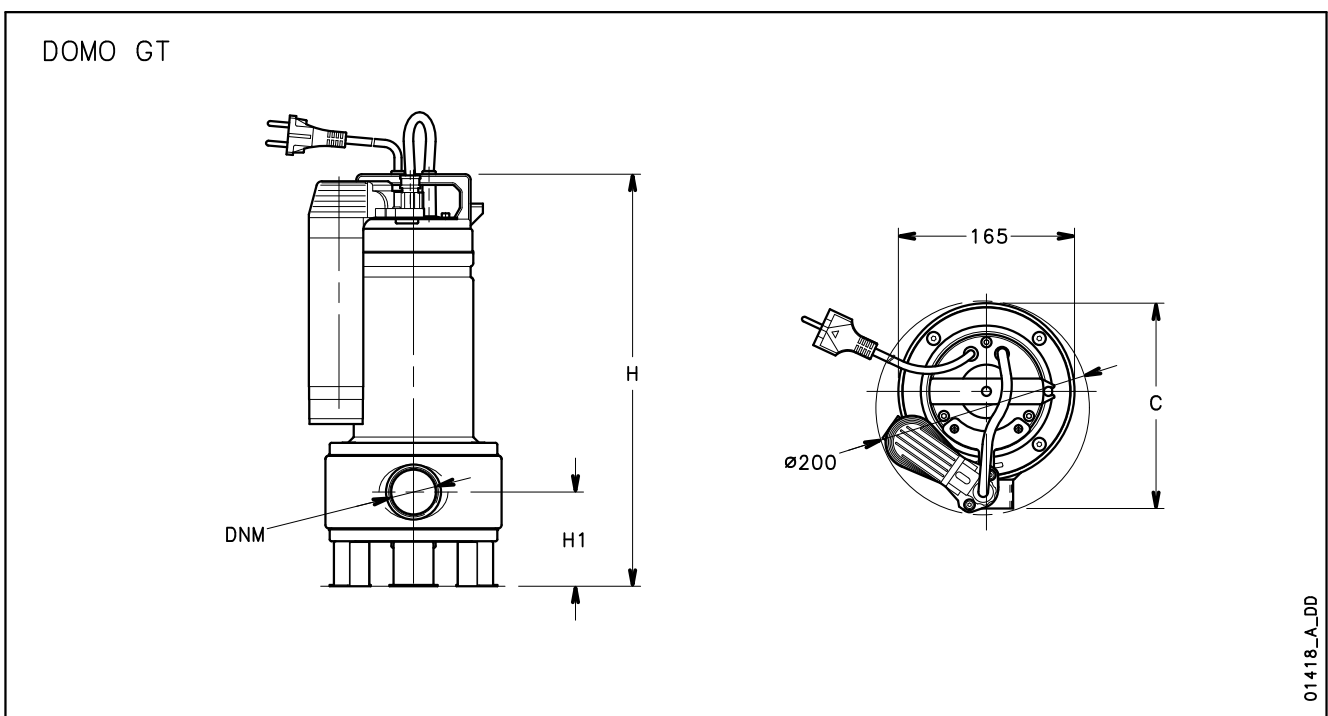

DOMO - DOMO GRI SERIES INSTALLATION EXAMPLES

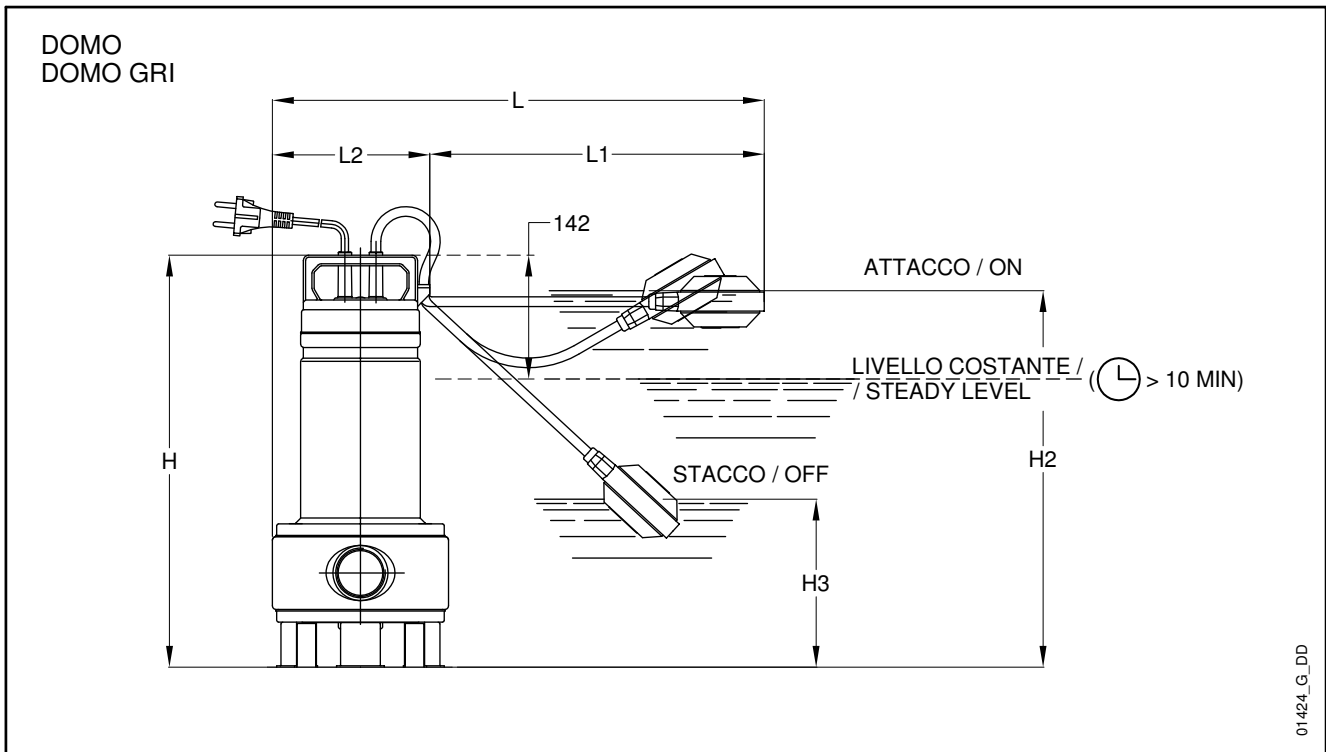

POMPA TIPO		DIMENSIONI (mm)						
		H	H2	H3	L	L1	L2	A
DOMO 7 - DOMO 7 GT	DOMO 7VX - DOMO 7VX GT	391	375	155	420	275	145	225
DOMO10 - DOMO10 GT	DOMO10VX - DOMO10VX GT	468	420	155	495	350	145	255
DOMO15 - DOMO15 GT	DOMO15VX - DOMO15VX GT	468	420	155	495	350	145	255
DOMO GRI 11(T)/A (SG)	DOMO GRI 15T	442	394	129	535	350	185	-
DOMO GRI 11(T)HF (SG)	-	444	396	131	535	350	185	-
DOMO GRI 15 (SG)	-	462	414	149	535	350	185	-

domoliv-2p50_f_td

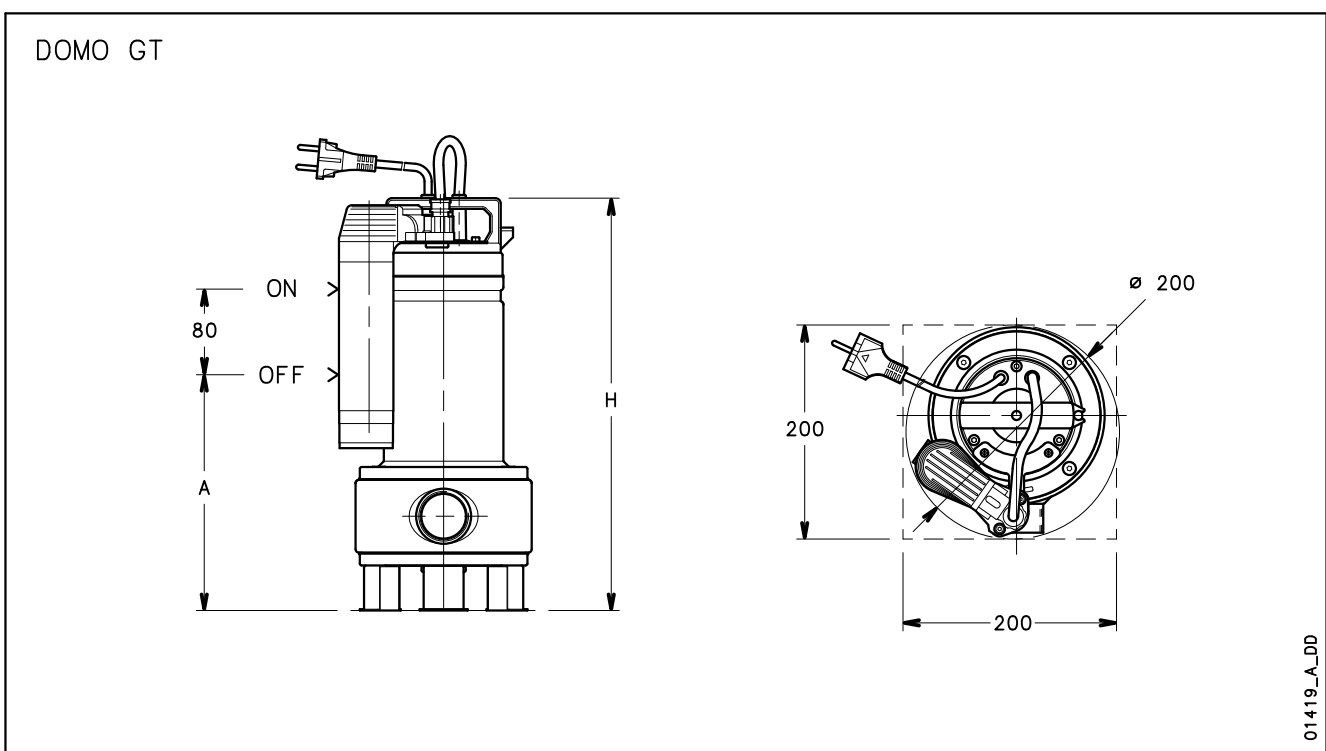

DOMO SERIES INSTALLATION WITH SD LOWERING DEVICE

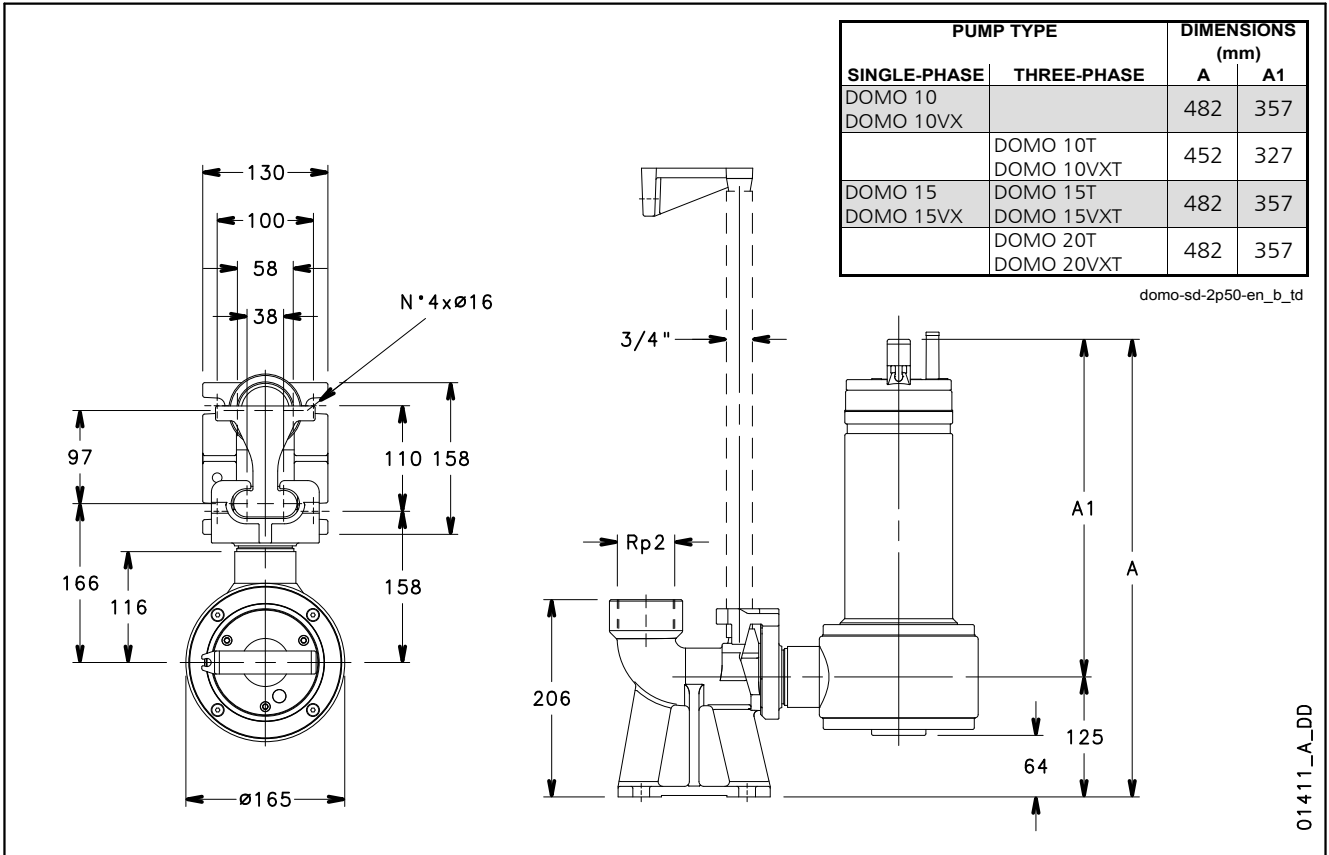

DOMO GRI SERIES DIMENSIONS AND WEIGHTS

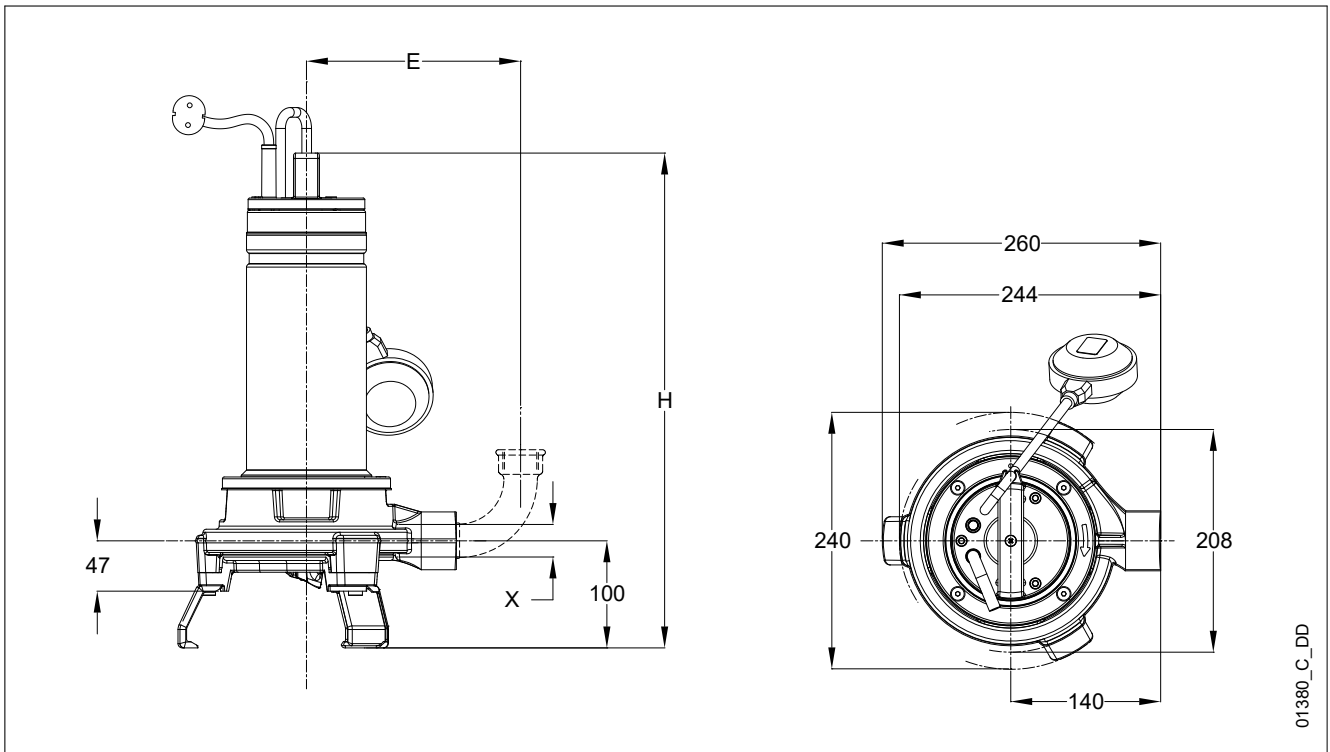

01380_C_DD

PUMP TYPE	DIMENSIONS (mm)			WEIGHT (kg)
	E	H	X	
DOMO GRI 11/A (SG)	200	442	Rp 1"	20,8 (20,6)
DOMO GRI 11T/A	200	442	Rp 1"	20,1
DOMO GRI 11HF (SG)	220	444	Rp 1" 1/4	20,8 (20,6)
DOMO GRI 11T HF	220	444	Rp 1" 1/4	20,1
DOMO GRI 15 (SG)	220	462	Rp 1" 1/4	23 (22,8)
DOMO GRI 15T	220	442	Rp 1" 1/4	22,3

domo-gri-en_d_td

INSTALLATION WITH SD LOWERING DEVICE

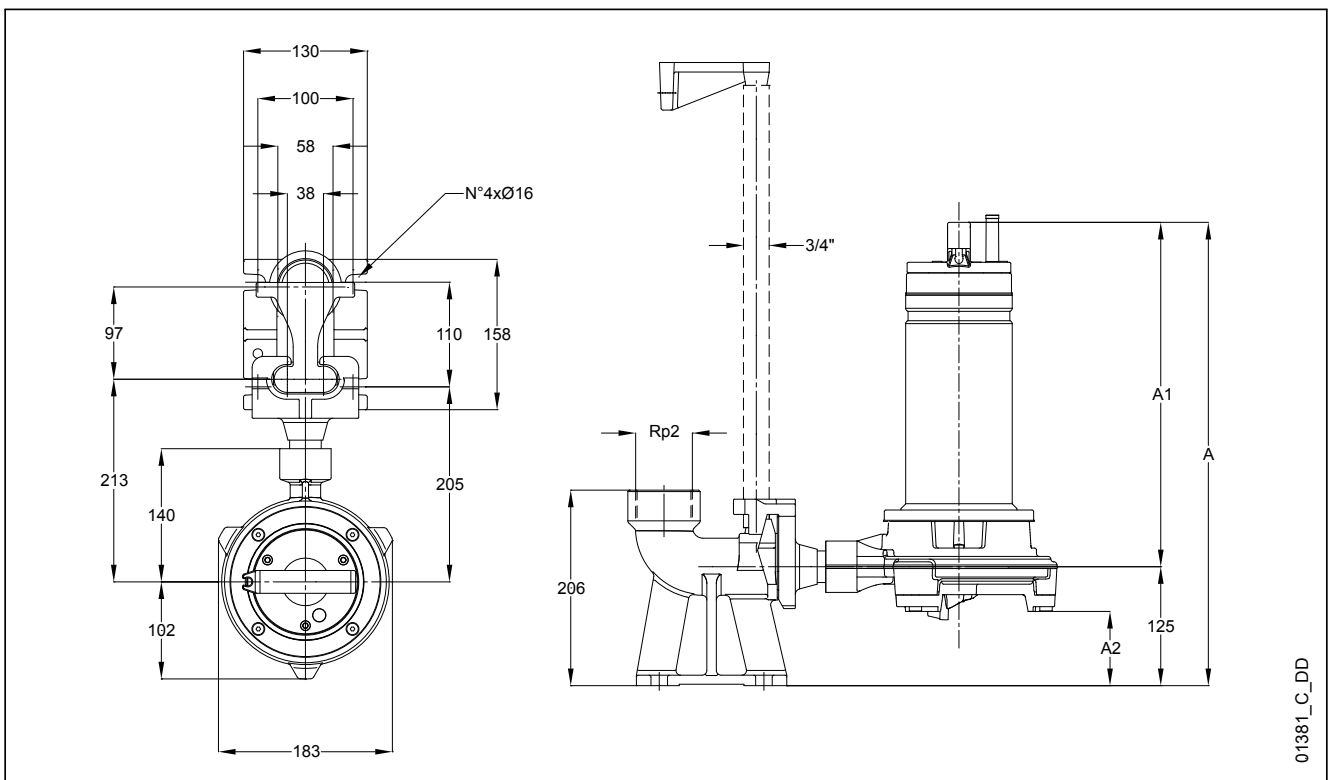

01381_C_DD

