

Submersible Electric Pumps for drainage of clean and slightly dirty water

DIWA Series



Submersible pumps for clean and slightly dirty water manufactured in AISI 304 stainless steel. Head up to 20 metres, delivery up to 420 l/min (25,2 m³/h). Four basic models with 0,55 to 1,5 kW.

DRIVELUB SEAL SYSTEM.

Diffuser plate coated with polyurethane for the maximum resistance to abrasion.

APPLICATIONS

- Draining of cellars, garages, basements. Draining of construction sites.
- Emptying of tanks and reservoirs.
- Lawn and garden irrigation.
- Pumping of domestic wastewater washing machines, showers, sinks.
- Emptying of tanks in industrial and ecological applications.

SPECIFICATIONS

- **Maximum liquid temperature: 50°C.**
- **Open impeller.**
- Minimum level of pumped liquid: **25 mm.**
- **Maximum dimensions of suspended solids: 8 mm.**
- **Dry motor** cooled by the pumped liquid.
- **Power cord: H07RN-F, 10 m.**
 - single-phase: with plug.
 - three-phase: without plug.
- **Insulation class 155°C (F).**
- **IPX8 protection.**
- **Maximum immersion depth: 7 m.**
- **Versions:**
 - Single-phase: 220-240V, 50Hz 2 poles.
 - Three-phase: 220-240V, 50Hz 2 poles. 380-415V, 50Hz 2 poles.
- **Motor power:**
 - Single-phase: **0,55 to 1,1 kW.**
 - Three-phase: **0,55 to 1,5 kW.**
- **The single-phase versions** feature:
 - **pre-assembled float switch** for automatic pump operation.
 - **built-in capacitor.**
 - **thermal overload protection** to stop pump supply in case of overheating.
- SG versions (single-phase without float switch), GT versions (single-phase with pre-assembled tube float switch), 60 Hz single-phase and three-phase versions, versions with various power cord lengths and various plugs are available on request

DRIVELUB SEAL SYSTEM

- Watertight electric motor protected by multiple seal system with **oil chamber.**
- A **V-ring** and **silicon carbide mechanical seal** (extremely resistant to wear and abrasion), as well as a **lip seal** which is continuously lubricated by the **DRIVELUB system**, provide an extreme barrier against infiltration.

DIWA SERIES IDENTIFICATION CODE

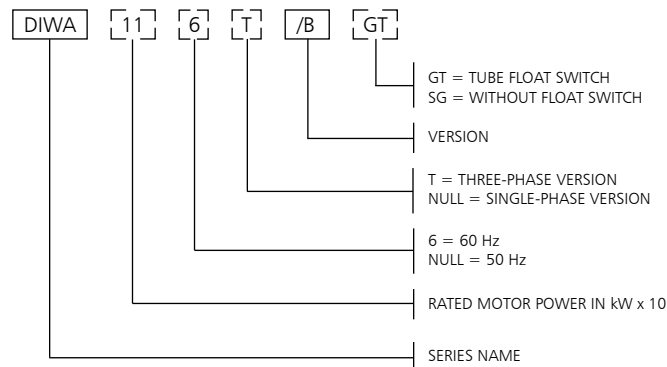

EXAMPLE : DIWA 11/B
DIWA Series Electric pump, rated motor power 1,1 kW,
50 Hz version, single-phase, /B version.

SINGLE-PHASE RATING PLATE

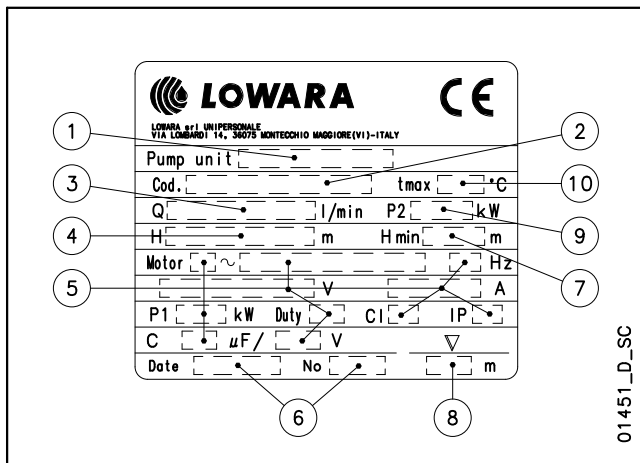

LEGEND

- 1 - Electric pump type
- 2 - Code
- 3 - Delivery range
- 4 - Head range
- 5 - Motor type
- 6 - Date of manufacture and serial number
- 7 - Minimum head
- 8 - Maximum immersion depth
- 9 - Rated output
- 10 - Maximum liquid temperature

THREE-PHASE RATING PLATE

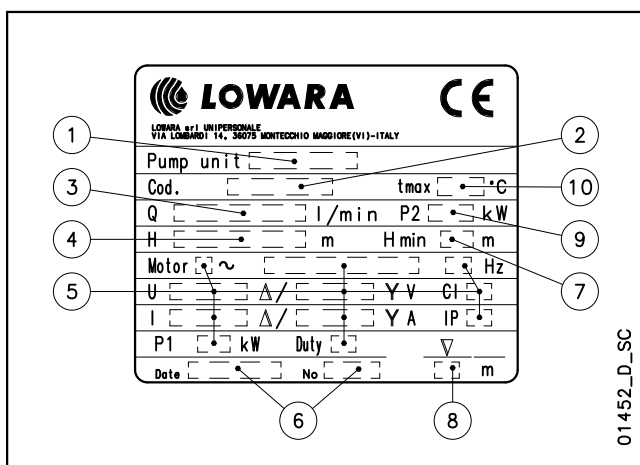

DIWA SERIES TABLE OF MATERIALS

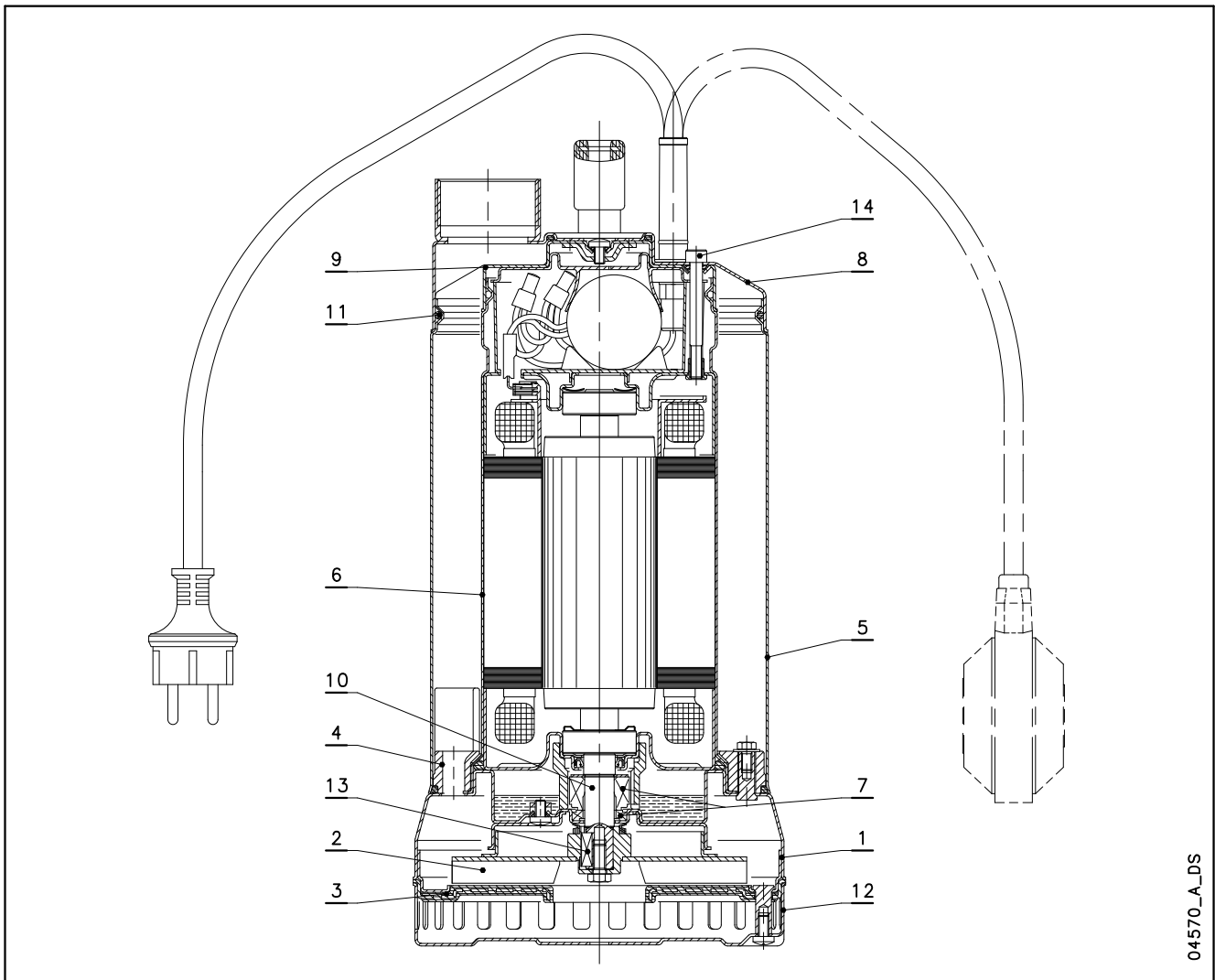

04570_A_DS

REF. N.	NAME	MATERIAL	REFERENCE STANDARDS	
			EUROPE	USA
1	Pump body	Stainless steel	EN 10088-1-X5CrNi18-10 (1.4301)	AISI 304
2	Impeller	Stainless steel	EN 10088-1-X5CrNi18-10 (1.4301)	AISI 304
3	Suction flange	Stainless steel	EN 10088-1-X5CrNi18-10 (1.4301)	AISI 304
		Thermoplastic polyurethane TPU		
4	Diffuser	PA 66 + 30 % GF		
5	Sleeve	Stainless steel	EN 10088-1-X5CrNi18-10 (1.4301)	AISI 304
6	Motor casing	Stainless steel	EN 10088-1-X5CrNi18-10 (1.4301)	AISI 304
7	Mechanical seal	Silicon carbide / Silicon carbide / NBR (standard version)		
8	Cover	Stainless steel	EN 10088-1-X5CrNi18-10 (1.4301)	AISI 304
9	Upper cover	Stainless steel	EN 10088-1-X5CrNi18-10 (1.4301)	AISI 304
10	Shaft end	Stainless steel	EN 10088-1-X5CrNi18-10 (1.4301)	AISI 304
11	Elastomers	NBR (standard version)		
12	Strainer	Stainless steel	EN 10088-1-X5CrNi18-10 (1.4301)	AISI 304
13	Key	Stainless steel	EN 10088-1-X5CrNiMo17-12-2 (1.4401)	AISI 316
14	Screws	Stainless steel	EN 10088-1-X5CrNi18-10 (1.4301)	AISI 304

diwa-en_b_tm

DIWA SERIES MECHANICAL SEAL

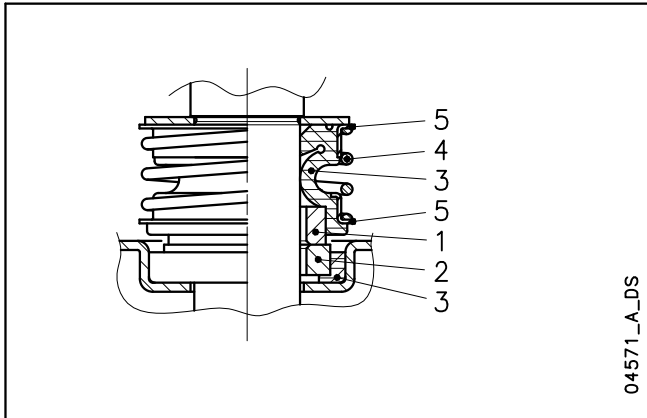

LIST OF MATERIALS

POSITION 1 - 2	POSITION 3	POSITION 4 - 5
Q1 : Silicon carbide	P : NBR	G : AISI 316
	V : FPM	

diwa_ten-mec-en_a_tm

SEAL TYPES

TYPE	POSITION					TEMPERATURE (°C)
	1 ROTATING ASSEMBLY	2 FIXED ASSEMBLY	3 ELASTOMERS	4 SPRINGS	5 OTHER COMPONENTS	
STANDARD MECHANICAL SEAL						
Q ₁ Q ₁ PGG	Q ₁	Q ₁	P	G	G	0 +50
OTHER MECHANICAL SEAL TYPES						
Q ₁ Q ₁ VGG	Q ₁	Q ₁	V	G	G	0 +50

diwa_tipi-ten-mec-en_b_tc

DIWA SERIES OPERATING CHARACTERISTICS AT 50 Hz

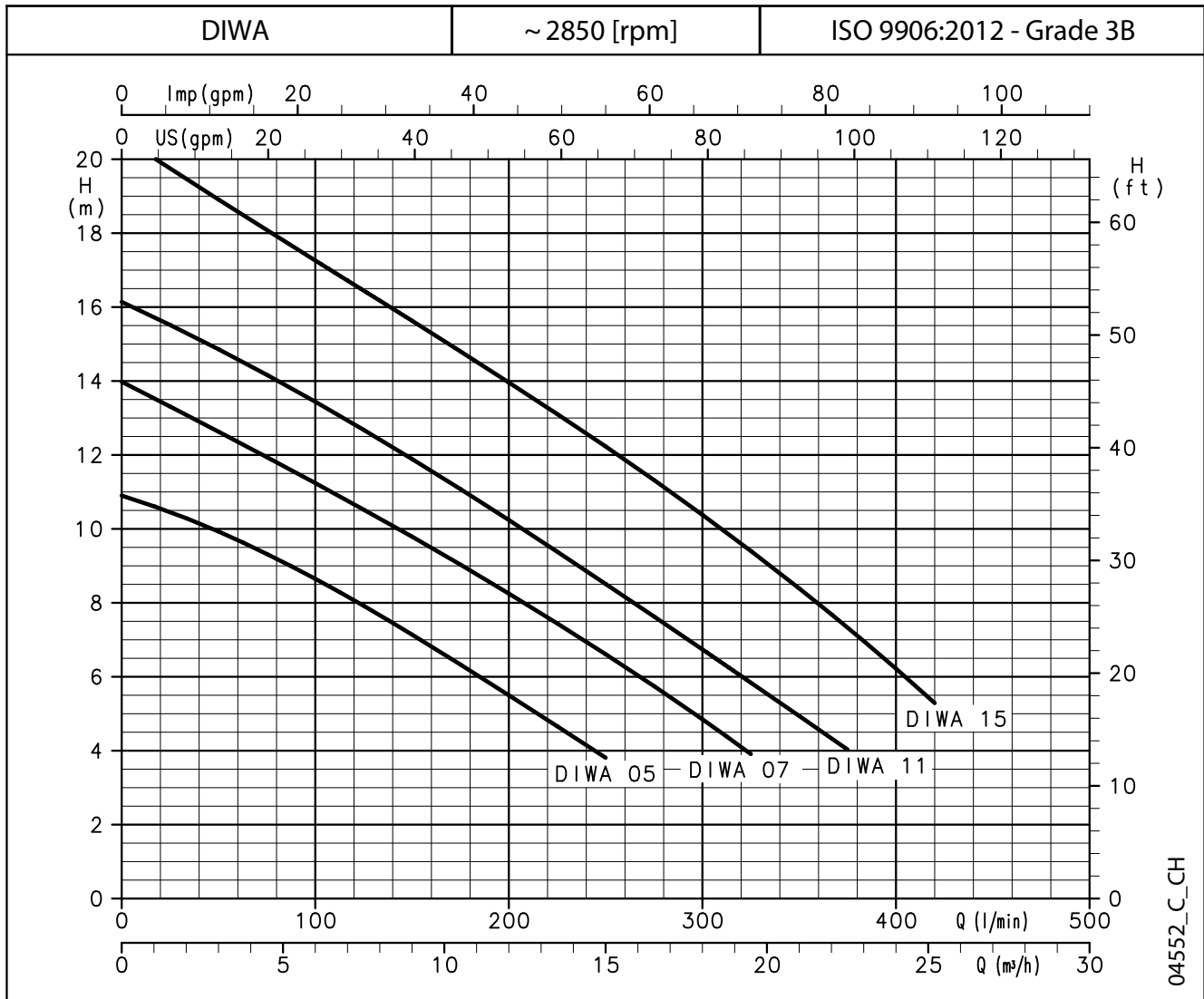

HYDRAULIC PERFORMANCE TABLE

PUMP TYPE	RATED POWER		Q = DELIVERY													
			l/min	0	100	125	150	175	200	225	250	300	325	375	420	
			m ³ /h	0	6	7,5	9	10,5	12	13,5	15	18	19,5	22,5	25,2	
		H = TOTAL HEAD METRES COLUMN OF WATER														
	kW	HP														
DIWA 05(T)	0,55	0,75	10,9	8,6	7,9	7,1	6,3	5,5	4,7	3,8						
DIWA 07(T)	0,75	1	14,0	11,2	10,5	9,8	9,0	8,3	7,4	6,6	4,8	3,9				
DIWA 11(T)	1,1	1,5	16,1	13,4	12,7	11,9	11,1	10,2	9,4	8,5	6,7	5,8	4,0			
DIWA 15T	1,5	2	20,6	17,3	16,4	15,6	14,8	14,0	13,1	12,2	10,4	9,4	7,3	5,3		

These performances are valid for liquids with density $\rho = 1,0 \text{ kg/dm}^3$ and kinematic viscosity $\nu = 1 \text{ mm}^2/\text{s}$.

diwa-2p50-en_a_th

ELECTRICAL DATA TABLE

PUMP TYPE	ABSORBED POWER*	ABSORBED CURRENT*	CAPACITOR
SINGLE-PHASE	kW	220-240 V A	$\mu\text{F} / 450 \text{ V}$
DIWA 05	0,79	3,92	16
DIWA 07	1,25	6,20	22
DIWA 11	1,53	6,83	30
-	-	-	-

PUMP TYPE	ABSORBED POWER*	ABSORBED CURRENT*	ABSORBED CURRENT*
THREE-PHASE	kW	220-240 V A	380-415 V A
DIWA 05T	0,72	2,56	1,48
DIWA 07T	1,2	4,26	2,46
DIWA 11T	1,44	4,64	2,68
DIWA 15T	2,05	6,74	3,89

*Maximum values within operating range

diwa-2p50-en_a_te

**DIWA SERIES
DIMENSIONS AND WEIGHTS**

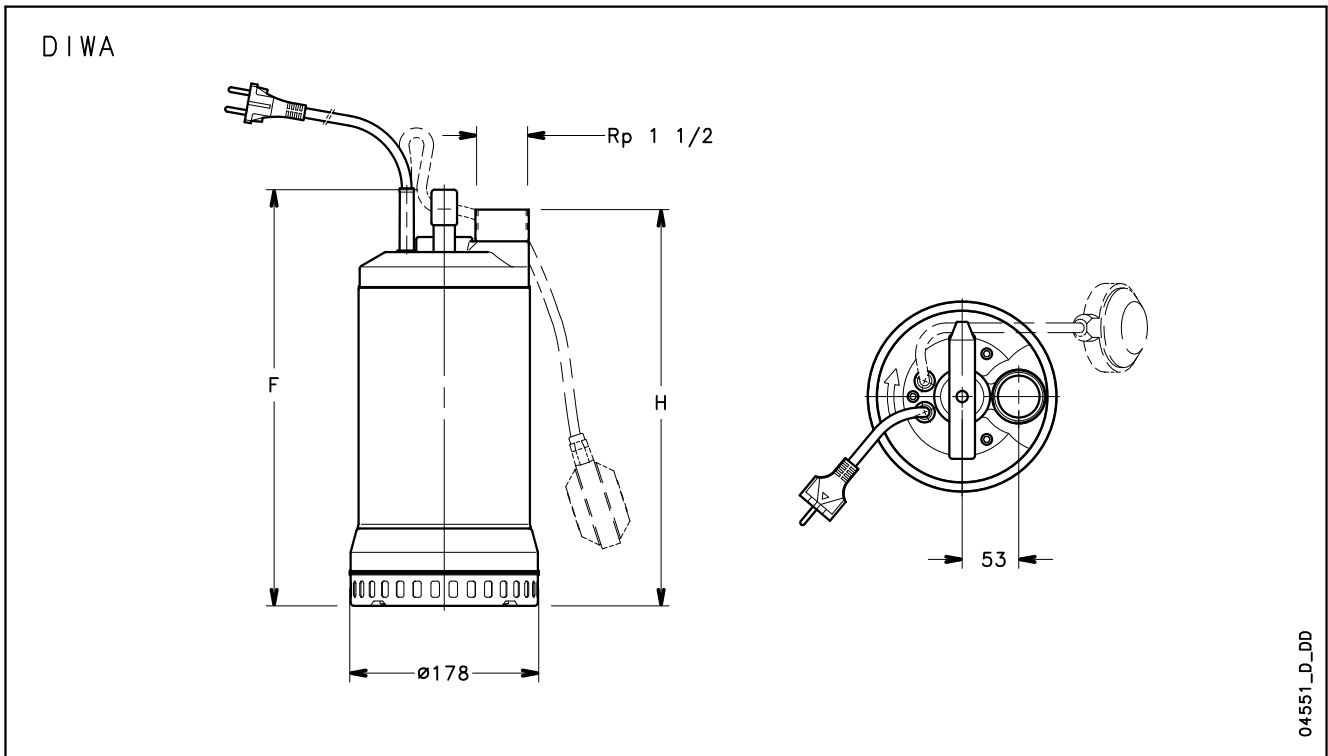

PUMP TYPE SINGLE-PHASE		DIMENSIONS (mm)		WEIGHT
		F	H	kg
DIWA05	DIWA05 GT	348	330	12
DIWA07	DIWA07 GT	393	375	14,3
DIWA11	DIWA11 GT	393	375	17
-	-	-	-	-

PUMP TYPE THREE-PHASE		DIMENSIONS (mm)		WEIGHT
		F	H	kg
DIWA05T		348	330	11
DIWA07T		363	345	13
DIWA11T		393	375	15
DIWA15T		393	375	16,5

diwa-2p50-en_b_td

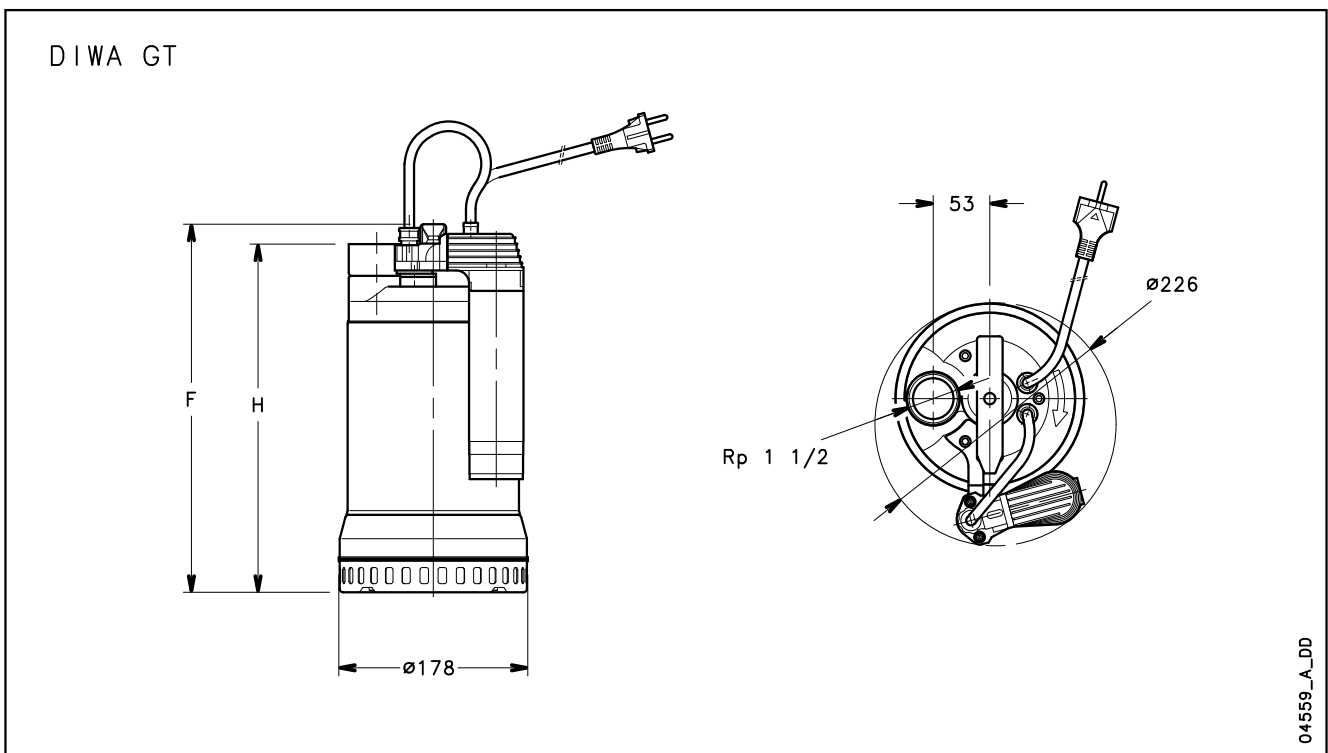

**DIWA SERIES
INSTALLATION EXAMPLES**

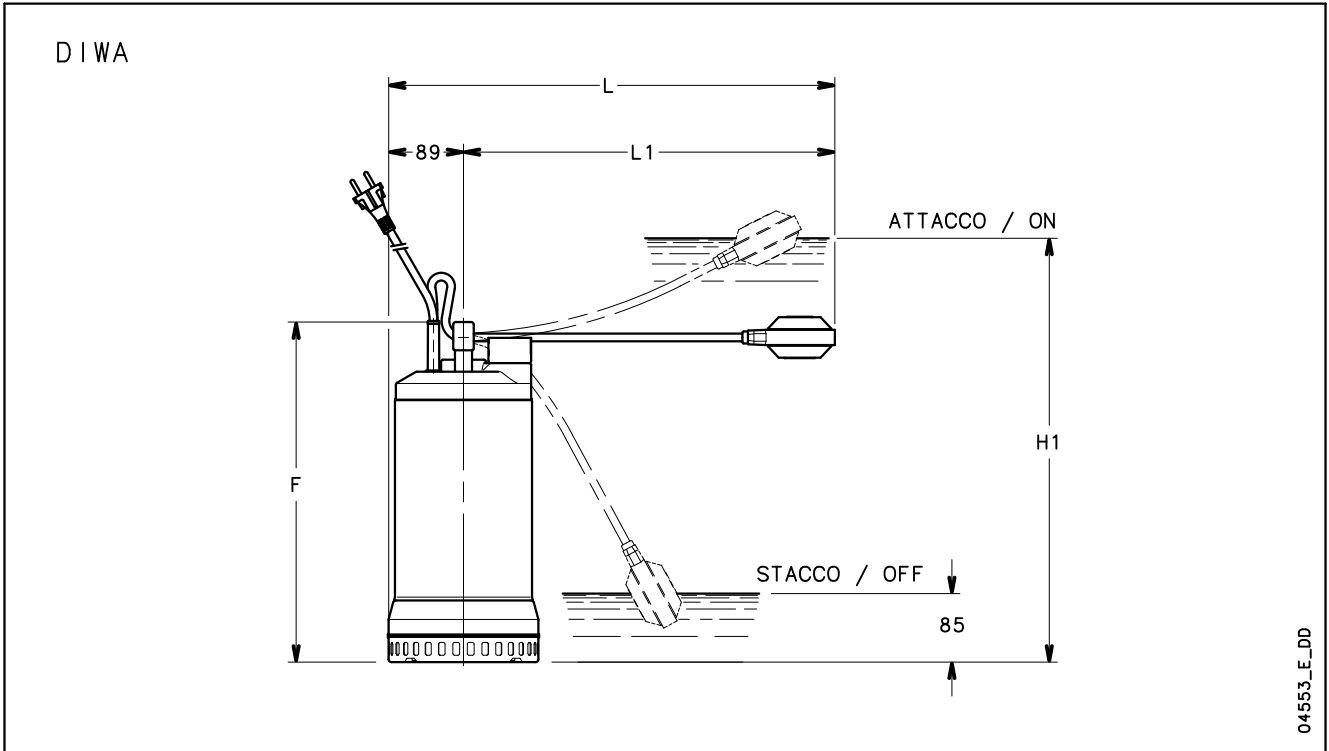

PUMP TYPE		DIMENSIONS (mm)				
		F	L	L1	H1	H2
DIWA05	DIWA05 GT	348	459	370	430	180
DIWA07	DIWA07 GT	393	504	415	490	180
DIWA11	DIWA11 GT	393	524	435	490	180

diwaliv-2p50-en_d_td

