

# OPERATION MANUAL

## Liquid Level Alarm

Deluxe - Metal Enclosure - FPC-12670

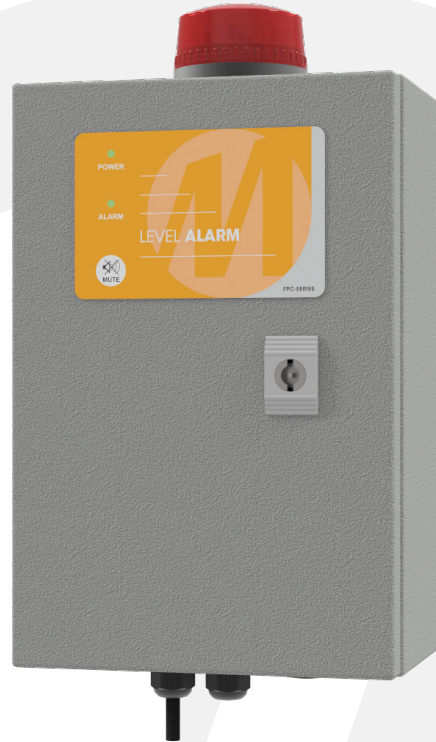

## Introduction

MATElec Australia's Liquid Level Alarm is designed to provide warning indication and alarm when a water storage tank is either empty or full. Housed in a robust powder coated metal enclosure, the Metal Enclosure version features audible and visual alarms and a keypad interface with status indicator lights and alarm mute button.

## Safety

This Liquid Level Alarm panel has been designed and built for applications that are Commercial and/or Industrial in nature, operation, function and location. If the control panel is to be used in Domestic/Residential applications, further consideration is required by the installer to ensure its suitability. It is the responsibility of the installing electrician to ensure compliance with relevant standards.

- Prior to installation, ensure power supply is isolated.
- Electrical connection to the panel must be carried out in accordance with the following pages.
- Additions or modifications to the control panel are not permitted and will void warranty.
- The controller is not intended for use by children or infirm persons without supervision.
- Repairs to the controller must only be carried out by a suitably qualified electrician.

This operation manual makes use of the following symbols to indicate warnings that must be paid specific attention to:



Damage to equipment or personal harm may occur if this instruction is not followed



Electrical risk (electrocution hazard) may occur if this instruction is not followed

# Functions & Fault Protection

## Level Alarm

The level alarm is activated when the input receives a closed contact. The alarm indicator light and strobe will illuminate, the buzzer with sound, and the volt free relay output will change state. The buzzer can be muted by pressing the mute button on the keypad. The level alarm automatically resets when the input receives an open contact.

## Auto Silencing Alarm

If not muted, the buzzer will automatically silence after 5 minutes and enter 'chirp' mode, sounding for 2 seconds every 5 minutes. This 'chirp' can be muted by pressing the mute button on the keypad. This feature can be disabled if a continuous alarm is required, by switching the jumper on the module to the 'continuous' position.

## Alarm Test

Holding down the mute button on the keypad for 2 seconds will trigger the alarm test. The alarm indicator light and strobe will illuminate, the buzzer will sound and the volt free relay output will change state. The alarm test will remain active until the mute button is released.

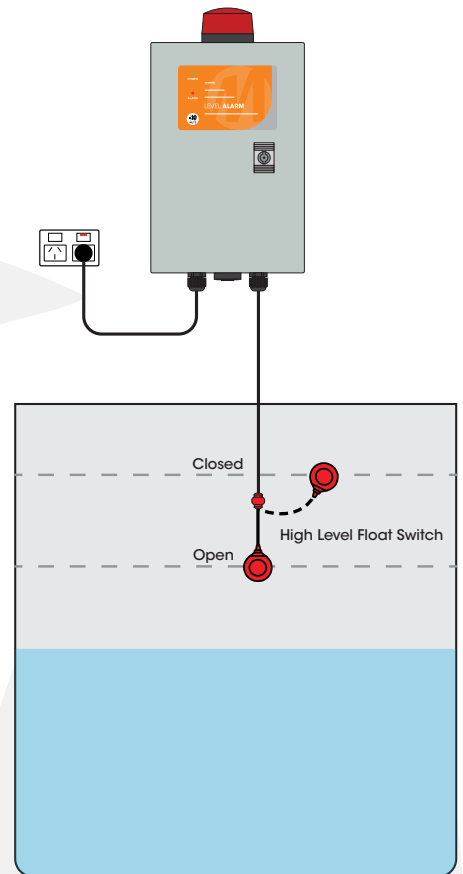

## Step 1 - Installation



- Liquid Level Alarm enclosure must be mounted in a vertical position.
- Ensure mounting method does not compromise enclosure weatherproof rating.
- Ensure cables/conduits entering the panel have mechanical protection and that the penetrations are sealed and do not compromise the weatherproof rating of the enclosure.

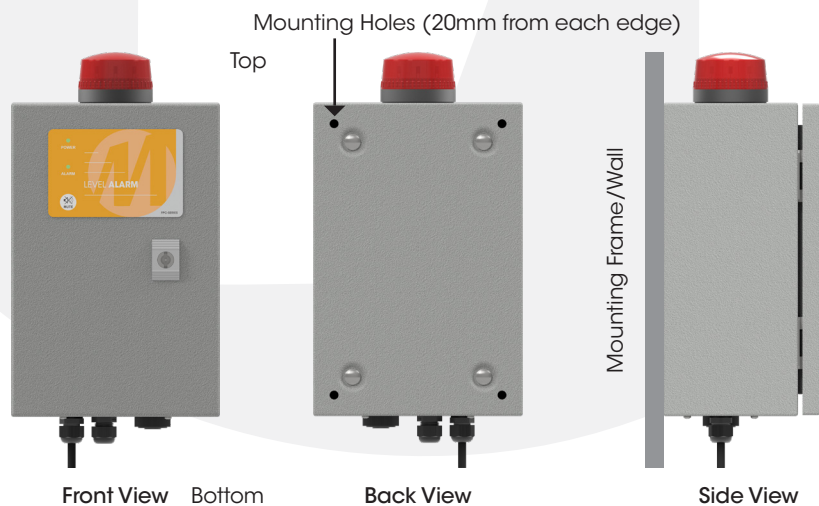

## Step 2 - Connections



**Warning: All electrical connections must be carried out by a suitably qualified and registered electrician**

### 2.1 - Control Module Connections

- For a high level alarm, connect **brown** and **black** float switch wires (close on rise configuration) to input terminals.
- For a low level alarm, connect **blue** and **black** float switch wires (close on fall configuration) to input terminals.
- For a high level alarm using conductivity probes, connect 2 probes to input terminals. **Note** - Reliable probe operation may be hindered by the water/liquid quality. Test the probes in the liquid in which they are to be submersed before use.
- Connect to volt free output if required. If connected to 'C' and 'NO' terminals, the output will close when the alarm is inactive and open when active or on power failure. If connected to 'C' and 'NC' terminals, the output will close when the alarm is active or on power failure.

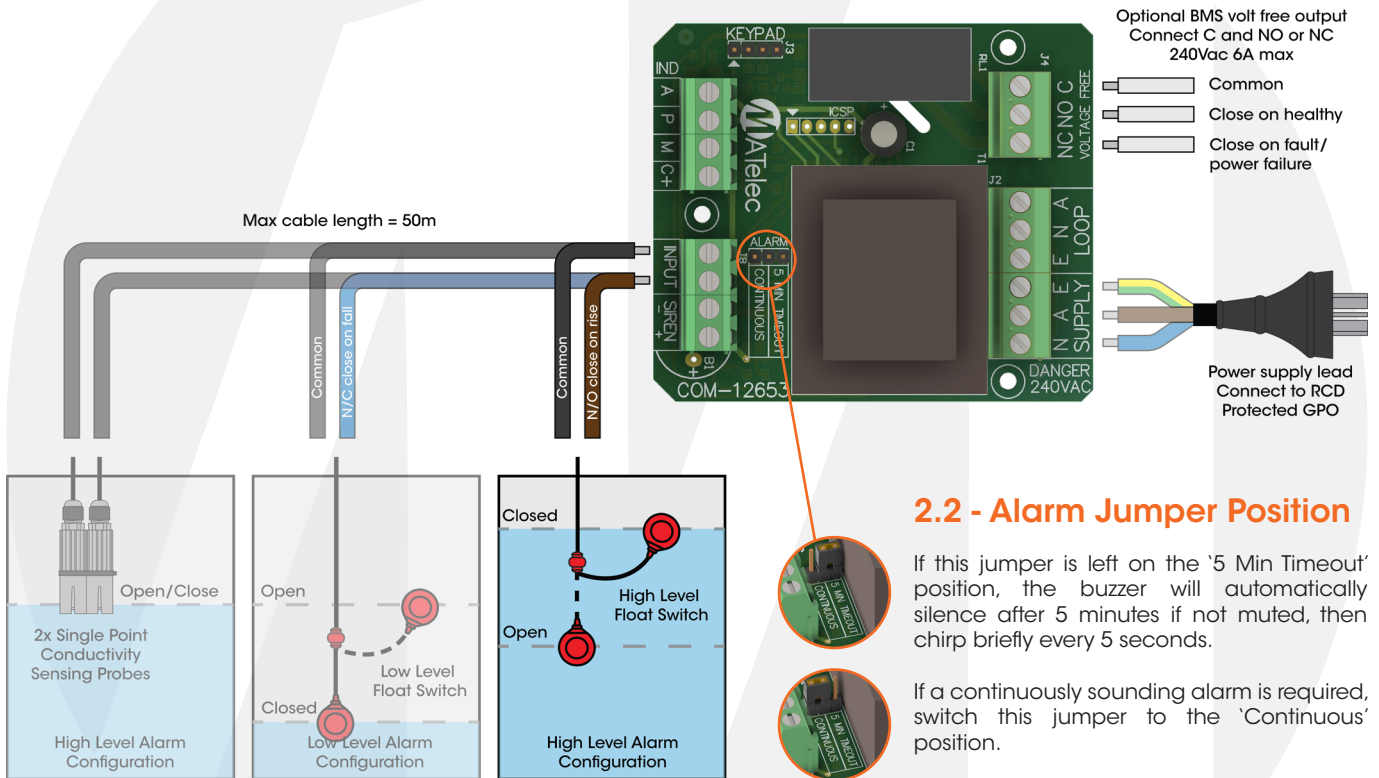

## Step 3 - Powerup



Close and secure enclosure door, connect the power lead into RCD protected GPO and switch on mains power.

## Keypad Operation

### Indicator Lights



Solid - Power on



Solid - Alarm active

### Push Buttons



Press for 1 sec - Mutes the buzzer  
Press for 2 sec - Tests alarm indicator light, strobe & buzzer



## Fault Diagnosis



**Warning - Any remedy that requires access inside the enclosure must be carried out by a suitably qualified and registered electrician.**

Fault	Cause	Remedy
Level alarm (alarm indicator light solid)	Water in the tank/pit is at the alarm level.	Inspect the level in the tank/pit. If at the alarm level, mute the alarm until the level rises/falls and the alarm condition subsides.
	Float switch or probes installed incorrectly.	Ensure the float switch or probes are installed at the correct height in the tank/pit, adjust if required.
	Moisture ingress into cable joins.	Check for moisture in any cable joins, repair if needed.
	Float switch wired incorrectly.	Check the float switch wiring into the input: <ul style="list-style-type: none"> <li>If a high level alarm is required, ensure the float switch is wired as close on rise (black and brown wires for MATElec float switches).</li> <li>If a low level alarm is required, ensure the float switch is wired as close on fall (black and blue wires for MATElec float switches).</li> </ul>
	Float switch damaged or faulty.	Disconnect the float switch from the input. If the alarm clears, the float switch may be faulty. With the float in the open position, test for leakage/shorts across the across the wires. Replace the float switch if required.
	Probe wires damaged.	Disconnect the probes from the input. If the alarm clears, the probe wires may be damaged. With the probes out of the liquid, test for leakage/shorts across the across the wires. Replace if required.
	Probe interference.	Check for any objects touching the probe sensing points.
	Liquid level alarm keypad damaged.	If disconnecting the input did not clear the alarm, disconnect the keypad ribbon from the module. If the alarm clears, the keypad is damaged and should be replaced.
	Liquid level alarm module faulty.	If disconnecting the input and keypad from the module did not clear the alarm, the module is damaged and should be replaced.
Level alarm not activating	Water in the tank/pit is not at the alarm level.	Inspect the level in the tank/pit. If not at the alarm level, the unit is operating correctly.
	Float switch or probes installed incorrectly.	Ensure the float switch or probes are installed at the correct height in the tank/pit. Adjust if required.
	Float switch wired incorrectly or damaged.	Check the float switch wiring into the input. <ul style="list-style-type: none"> <li>If a high level alarm is required, ensure the float switch is wired as close on rise (black and brown wires for MATElec float switches).</li> <li>If a low level alarm is required, ensure the float switch is wired as close on fall (black and blue wires for MATElec float switches).</li> <li>After checking the float is wired correctly, raise/lower the float to test. If the alarm still doesn't activate, the float switch/cable is damaged, replace if required.</li> </ul>
	Conductivity probes dirty, liquid not conductive enough or cable length too long.	Lower probes into the liquid to test if alarm activates. If not, do the following: <ul style="list-style-type: none"> <li>Remove the probes from the tank/pit, clean any build up of material on the probes, then lower them down into the liquid and test if the alarm activates.</li> <li>If not, remove the probes from the tank/pit, check cables for damage and test for continuity between the sensing point and cable termination. Replace if needed.</li> <li>Probe cable lengths in excess of 50m can cause inconsistent operation.</li> <li>The liquid in which the probes are submersed may not be conductive enough for the probes to operate reliably. Replace with a float switch or use the Liquid Level Alarm with conductivity relay (FPC-12665), which has sensitivity adjustment.</li> </ul>
	Liquid level alarm module faulty.	If no other remedies were successful, bridge the input. If the alarm still does not activate, the module is damaged and should be replaced.
Alarm test not working	Liquid level alarm keypad damaged.	If the indicator light, strobe and buzzer fail to activate when the mute button is held down for 2 seconds, the keypad is damaged and should be replaced.
No power on indication	Liquid Level Alarm does not have power.	Connect and switch on the power supply to the panel. The power on indicator light will be illuminated when power is on.
	Keypad ribbon not connected.	Ensure the keypad ribbon is connected to the control module 'keypad' pins. If connected and still not working, the ribbon may be in the wrong orientation. Rotate the ribbon 180° on the module pins.
	Liquid level alarm keypad or module damaged.	Press the mute button on the keypad for 2 seconds (test this with the keypad ribbon connected to the module pins in both orientations). If the alarm activates, but the power on indicator does not, the keypad is damaged and needs replacing. If the alarm does not activate, the control module is damaged and needs replacing.