

6" SAND FIGHTER SUBMERSIBLE MOTORS



Motors
Drives
Controls
Protection
Accessories

Three-Phase 5.5 - 45 kW

Application Data

The Sand Fighter™ sealing system is a Franklin Electric exclusive. This innovative sealing system utilizes proprietary manufacturing methods and an optimized mechanical seal with silicon-carbide seal faces. Sand Fighter is an ideal motor choice for abrasive applications.

The Sand Fighter motor is a standard 30 °C (86 °F) water well motor manufactured with the Sand Fighter sealing system as standard. Many of the popular ratings are available from stock.

Franklin's SubMonitor overload protection option extends motor warranty to three years. The SubMonitor protection system guards the motor against overload, underload, excessive winding temperature and rapid cycling.

Basic Features:

- FE exclusive Sand Fighter sealing system
- Subtrol-plus heat sensor equipped
- A complete line of single-phase control boxes are available from Franklin Electric.
- Full 3450 RPM @ 60 Hz design point for superior pump head & flow yield
- Full rated kW output at 30 °C (86 °F) Ambient & 0.5 ft/sec flow by the motor
- High temperature winding wire rated 180 °C (356 °F)
- Hermetically-sealed winding area to seal the winding from moisture
- Winding resin encapsulation ensures the stability of the windings; thus, extends motor life
- FE encapsulating resin provides unique anti-tracking properties, higher surge resistance & excellent heat transfer
- FE FES91 water soluble fill and bearing lubrication solution is environmentally safe - no oil
- FE exclusive Water-Bloc™ connection allows the lead to be replaced in the field
- Copper bar rotors provide more consistent performance than other designs
- Double flange design increases ease and safety of handling the motor and mounting the pump
- Steel/carbon Kingsbury-type thrust bearings provide the best performance in water lubricated motors
- Stainless steel shell provides corrosion resistance
- Spline shaft provides maximum shaft/coupling contact
- Spring loaded equalizing diaphragm provides superior pressure compensation
- 316 SS and Y-Δ designs are available, consult factory



Franklin Electric

Availability

Three-Phase

HP	KW	Downward Thrust	"L" Dim		Shipping Weight	
			IN	CM	LBS	KG
5	3.7	3500 lbs. 15500 N	22.9	58.1	103	47
7.5	5.5	3500 lbs. 15500 N	24.2	61.4	110	50
10	7.5	3500 lbs. 15500 N	25.4	64.6	118	54
15	11	3500 lbs. 15500 N	28.0	71.1	131	60
20	15	3500 lbs. 15500 N	30.6	77.6	147	67
25	18.5	3500 lbs. 15500 N	33.1	84.2	158	72
30	22	3500 lbs. 15500 N	35.7	90.7	176	80
40	30	6000 lbs. 27500 N	40.8	103.7	206	94
50	37	6000 lbs. 27500 N	55.3	140.5	300	136
60	45	6000 lbs. 27500 N	61.3	155.7	330	150

Note: 60 Hz - 3,450 RPM. 50 Hz - 2,875 RPM

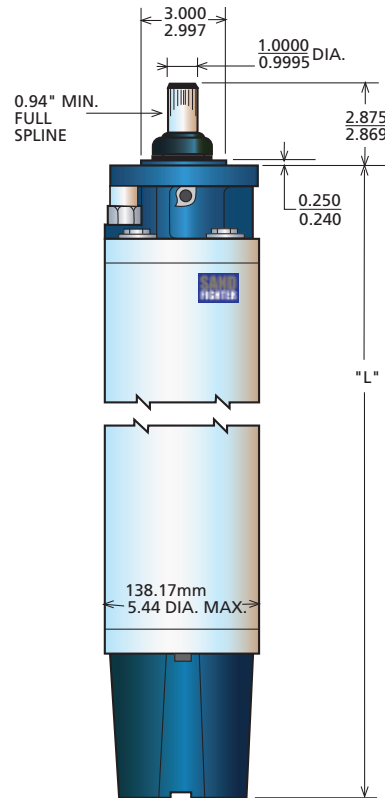

Construction Material

Component	Standard WW	Stainless Steel
1 Castings	Gray Iron	316 SS
2 Stator Shell	301 SS	316 SS
3 Stator Ends	Low Carbon Steel	316 SS
4 Shaft Extension	303 SS, Except 17-4 SS on 40-60 hp	17-4 SS
5 Fasteners	300 & 400 Series SS	316 SS
6 Seal Cover	304 SS & Sintered Bronze	316 SS
7 Seal	Sand Fighter™ SiC/SiC Mech Seal	Sand Fighter™ Sealing System
8 Diaphragm	Nitrile Rubber	Viton Rubber
9 Diaphragm Plate	304 SS	316 SS
10 Diaphragm Spring	302 SS	17-7 SST
11 Slinger	Nitrile Rubber	Viton Rubber
12 Lead Wire (or Cable)	XLPE	XLPE
13 Lead Potting	Epoxy	Epoxy
14 Filter	Delrin & Polyester	NA
15 Pipe Plug	NA	316 SS

Specifications subject to change without notice.

Contact Franklin Electric if current material types are required for bid specifications.



Franklin Electric

Franklin Electric (Aust) Pty Ltd
106-110 Micro Circuit
Dandenong South, Vic 3175
Tel: +61 3 9799 5000

Toll Free: 1300 FRANKLIN
1300 372 655

franklin-electric.com.au

400 East Spring Street, Bluffton, Indiana 46714
Tel: 260.824.2900 Fax: 260.824.2909
www.franklin-electric.com