

## MH 9 - TECHNICAL DATA

SINGLE-PHASE* 220-240 V		THREE-PHASE** 380-415 V		NO. OF STAGES	MOTOR POWER		INPUT POWER	INTERNAL CAPACITOR		RATED CURRENT		
MODEL NO.	ORDER NO.	MODEL NO.	ORDER NO.		KW	HP		KW	μF	V	SINGLE-PHASE 220-240 V	THREE-PHASE 220-240 V 380-415 V
9AMH2B-51	96141009102	9AMH2B-53	96141009302	2	0.75	1	0.90	16	450	4.3	3.1	1.8
9AMH3B-51	96141009103	9AMH3B-53	96141009303	3	1.1	1.5	1.37	30	450	6.4	4.7	2.7
9AMH4B-51	96141009104	9AMH4B-53	96141009304	4	1.5	2	1.77	30	450	8.2	6.1	3.5
-	-	9AMH5B-53	96141009305	5	1.85	2.5	2.21	-	-	-	6.9	4.0
-	-	9AMH6B-53	96141009306	6	2	2.7	2.61	-	-	-	7.8	4.5
-	-	9AMH7B-53	96141009307	7	3	4	3.18	-	-	-	11.0	6.4
-	-	9AMH8B-53	96141009308	8	3	4	3.59	-	-	-	12.0	6.9

\*Single-phase motors: 220-240 V ± 5 % / 50 Hz. Thermal protection built into the motor.

\*\*Three-phase motors: 380-415 V ± 5 % / 50 Hz. Thermal protection to be provided into the starter panel by the installer.

## MH 9 - DIMENSIONS

SINGLE-PHASE 220-240 V	THREE-PHASE 380-415 V	DIMENSIONS													WEIGHT (KG)		
		MM						IN		MM					SINGLE-PHASE	THREE-PHASE	
MODEL NO.	MODEL NO.	A	E	C	D	F	G	DN1	DN2	ØB	H	L1	L2	L3			
9AMH2B-51	9AMH2B-53	118	262	158.6	192	380	120	1.5 BSP	1 BSP	144	207	74	100.6	-	11.5	11.3	
9AMH3B-51	9AMH3B-53	118	262	158.6	192	380	120			144	207	74	100.6	-	-	13.1	12.9
9AMH4B-51	9AMH4B-53	148	304	188.6	222	452	124			162	214	74	128.1	-	-	17.1	16.8
-	9AMH5B-53	178	304	218.6	252	482	124			162	214	74	128.1	-	-	-	17.5
-	9AMH6B-53	208	304	248.6	282	512	124			162	214	74	128.1	192.1	-	-	18.1
-	9AMH7B-53	238	349	278.6	312	587	131			179	221	74	171.6	222.1	-	-	25.5
-	9AMH8B-53	268	349	308.6	342	617	131			179	221	74	171.6	252.1	-	-	26.1

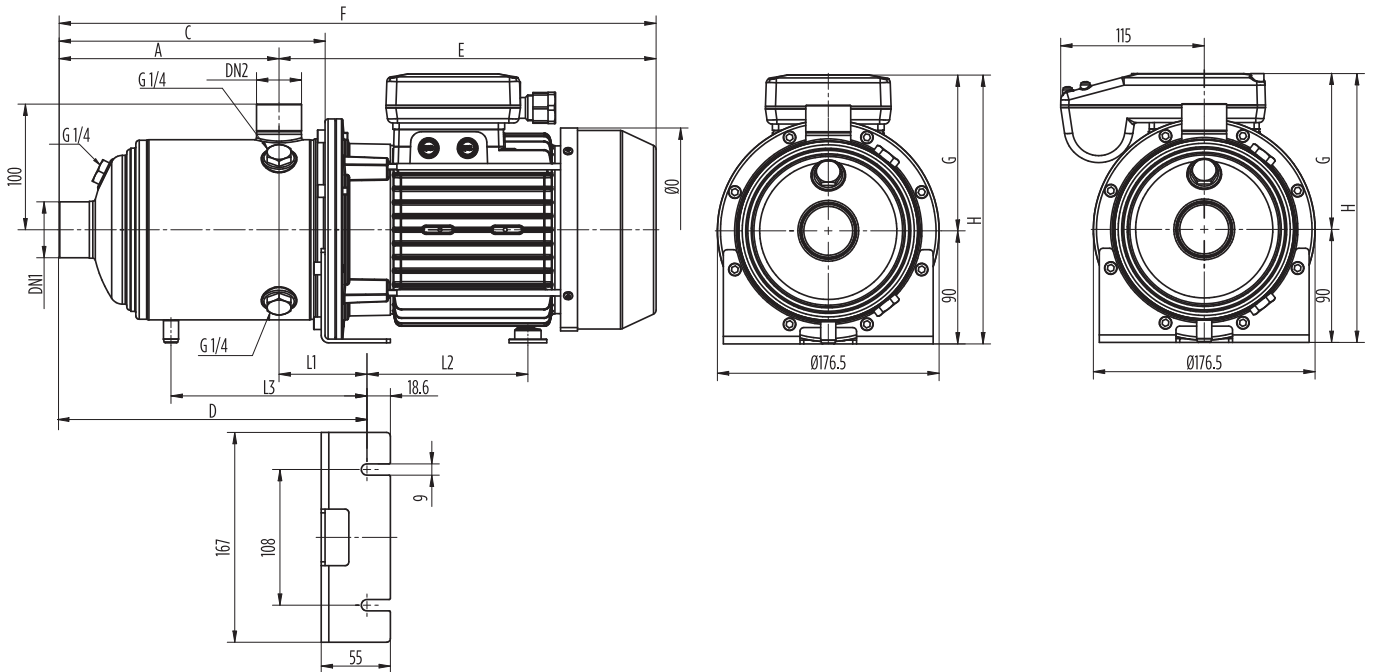

## MH 9 - PERFORMANCE

