

MP 3102 LT 3~ 210

Performance curve

Pump

Outlet width	50 mm
Inlet diameter	85 mm
Impeller diameter	168 mm
Number of blades	6

Motor

Motor #	M3102.170 18-10-2AL-W 4,4KW
Stator variant	
Frequency	50 Hz
Rated voltage	415 V
Number of poles	2
Phases	3~
Rated power	4.4 kW
Rated current	8.2 A
Starting current	54 A
Rated speed	2855 rpm

Power factor	
1/1 Load	0.94
3/4 Load	0.92
1/2 Load	0.88
Efficiency	
1/1 Load	79.5 %
3/4 Load	81.0 %
1/2 Load	80.5 %

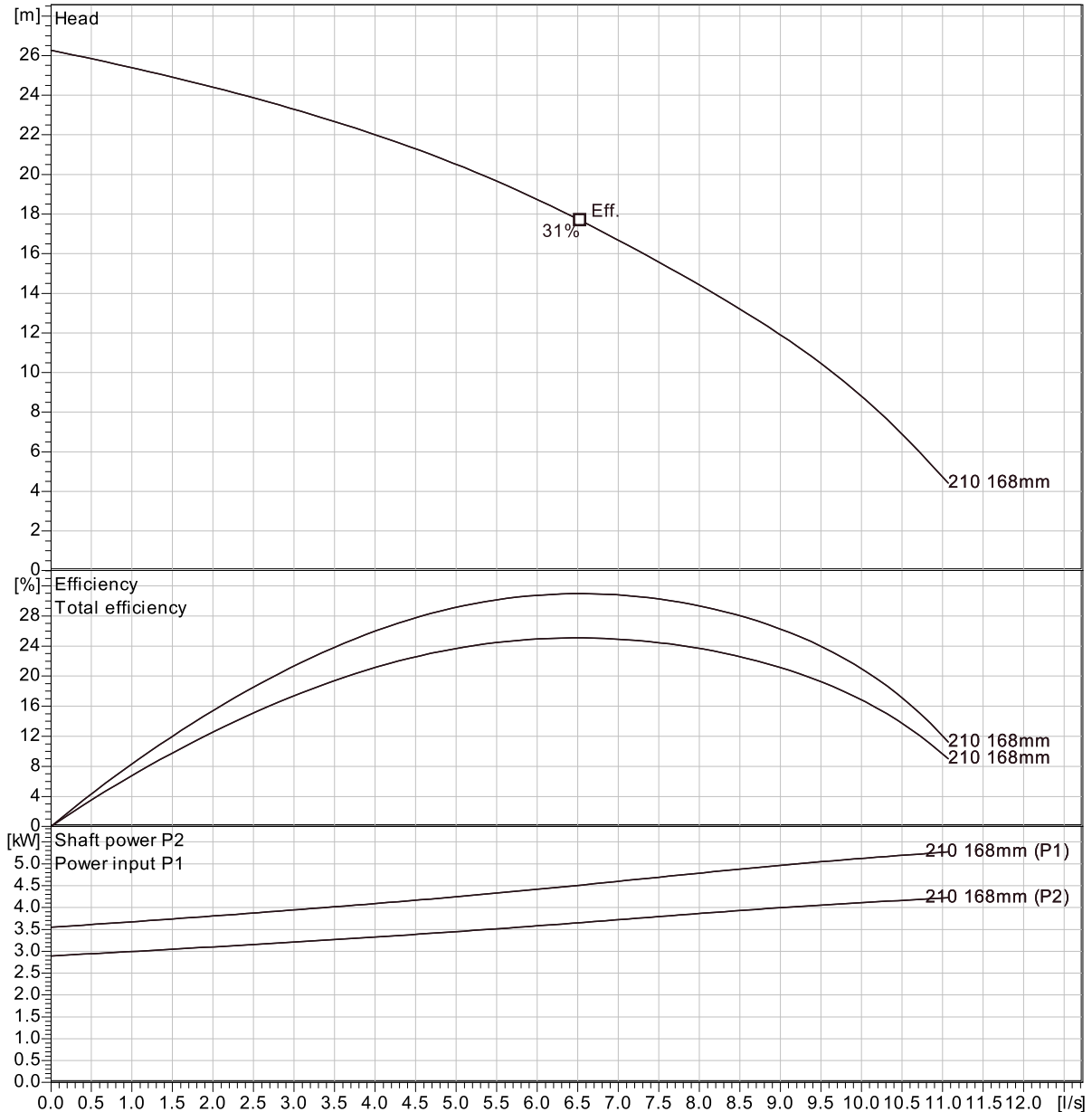

Curve according to: ISO 9906

Project	Project ID	Created by	Created on 2012-10-25	Last update
---------	------------	------------	---------------------------------	-------------

MP 3102 LT 3~ 210
Duty Analysis

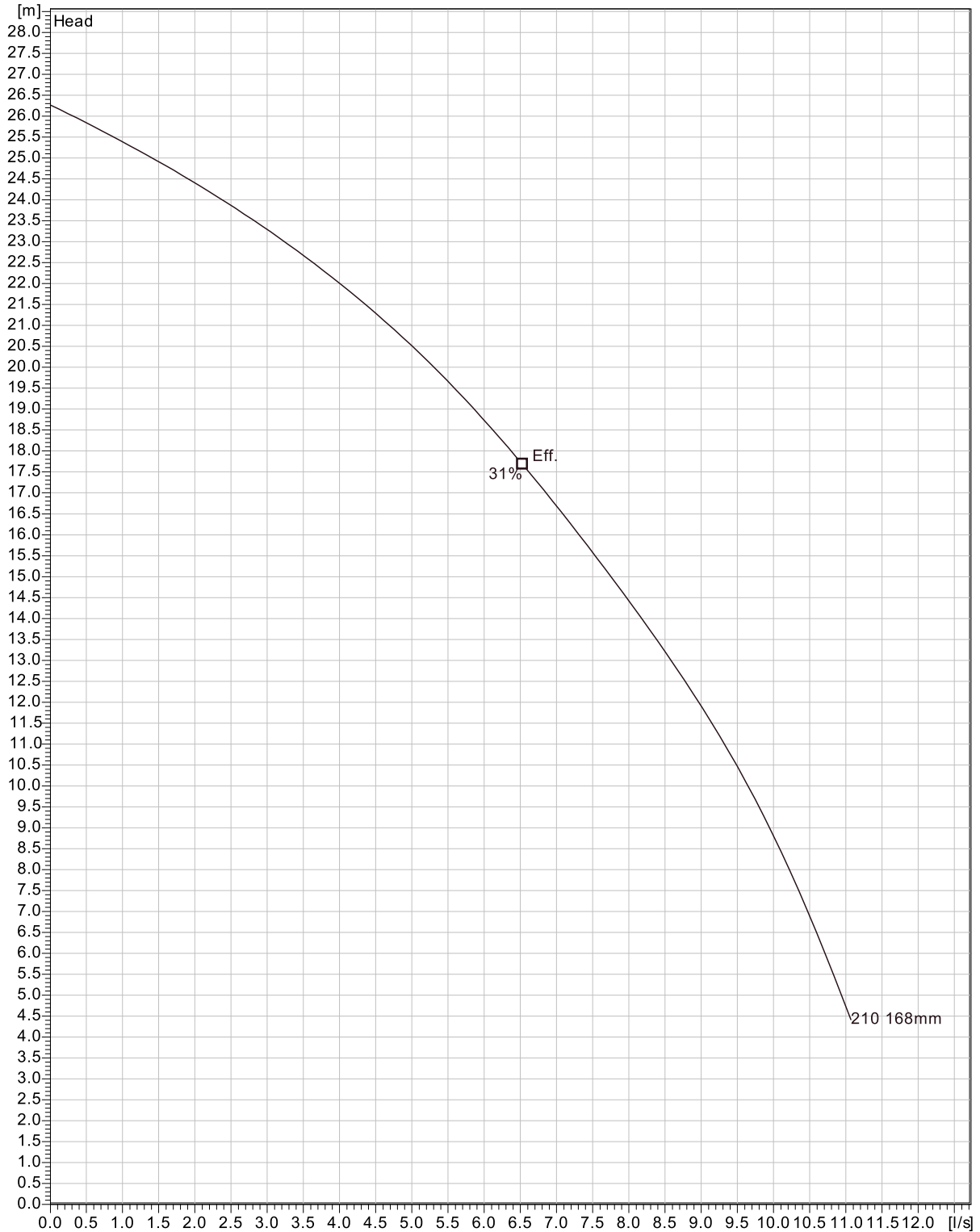

Curve according to: ISO 9906

Project	Project ID	Created by	Created on	Last update
			2012-10-25	

MP 3102 LT 3~ 210
Dimensional drawing

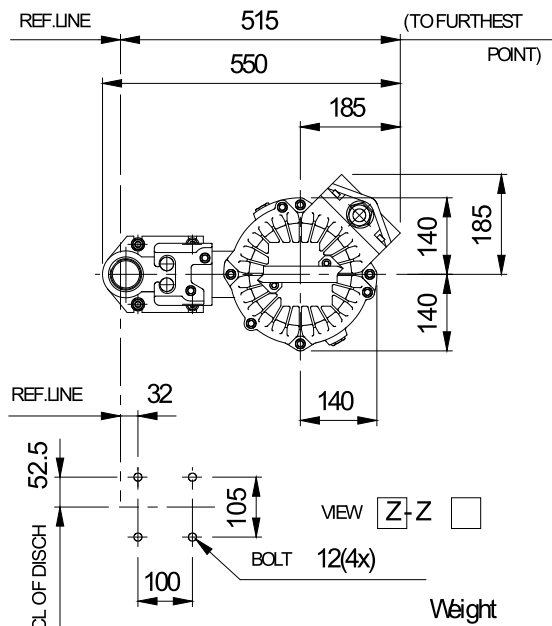
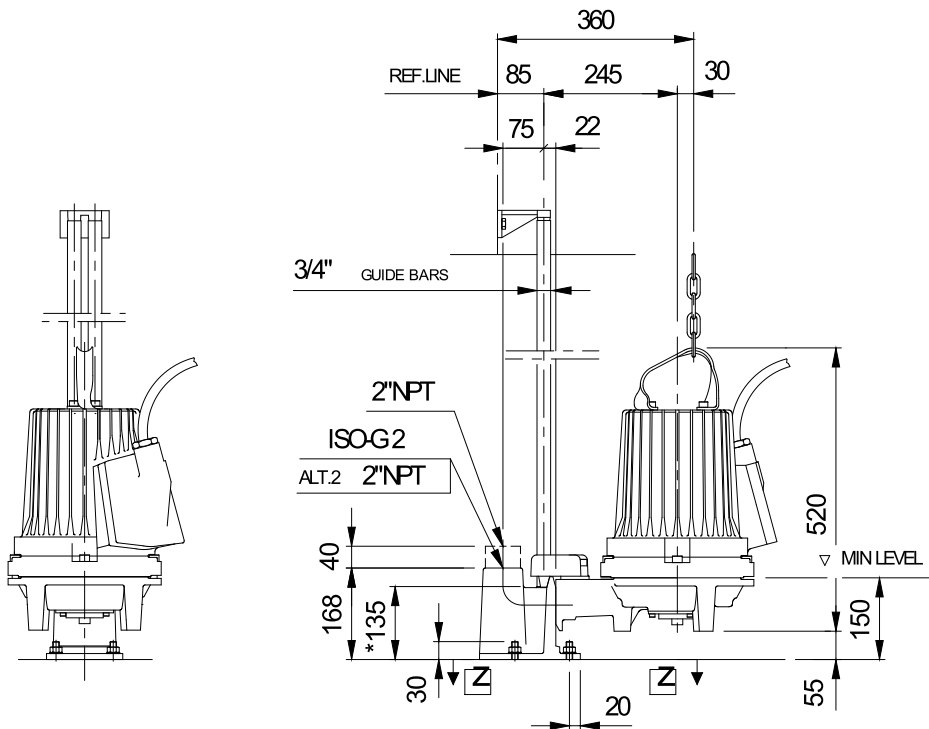

* DIMENSION TO ENDS OF GUIDE BARS

Dimensional dwg
MP3102LT

Project	Project ID	Created by	Created on	Last update
			2012-10-25	