

# DS25 1" (25NB)

## Pump Specifications

Model No.	DS25
Port Size:	1" (25NB) BSPP Female
Max. Flow:	23 L/min
Max. Suction Lift:	6m
Max. Discharge Head:	6m
Max. Solid Size:	15mm
Weight:	38 KG

## Motor Specifications

Brand:	Weg W22 Single Phase
kW:	.25
RPM:	1440
Voltage:	240
FLC:	1.85 amps
IP Rating:	55
Lead / Plug:	2m Flex. / 3 Pin

## Materials of Construction

Diaphragm:	Nitrile
Valves:	Nitrile
Castings:	SG Iron E-Coated
Base Plate:	Mild Steel E-Coated

Options:	EPDM & Viton
Options:	EPDM, Viton & Polyurethane
Options:	Bronze & Stainless Steels
Options:	Stainless Steel, Carry & Trolley Frame

## Recommended Accessories

Discharge Pulsation Dampener	Part No. PD1D
Suction Pulsation Dampener	Part No. PD1S
Fluid End Service Kit	Part No. D25K1



MINIMUM INTERNAL PIPE SIZE FOR LIQUIDS WITH SAME VISCOSITY AS WATER					
	SUCTION PIPE LENGTH M		DISCHARGE PIPE LENGTH M		
PUMP SIZE	0 - 5	5 - 10	0 - 5	5 - 10	10 - 20
D25	25	32	32	40	40
	SUCTION PIPE ID IN MM		DISCHARGE PIPE ID IN MM		
<b>USE OF PIPES SMALLER THAN STATED WILL VOID WARRANTY</b>					

Please refer to D Series Installation & Maintenance manual before installing or servicing the diaphragm pump.

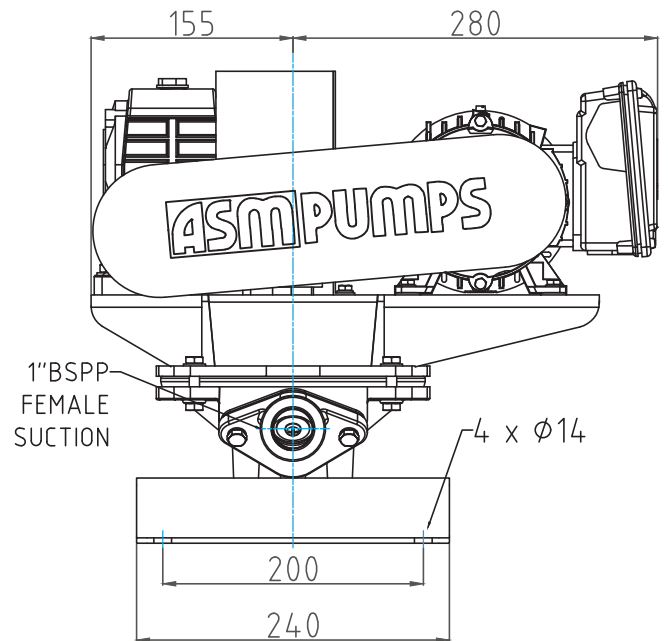
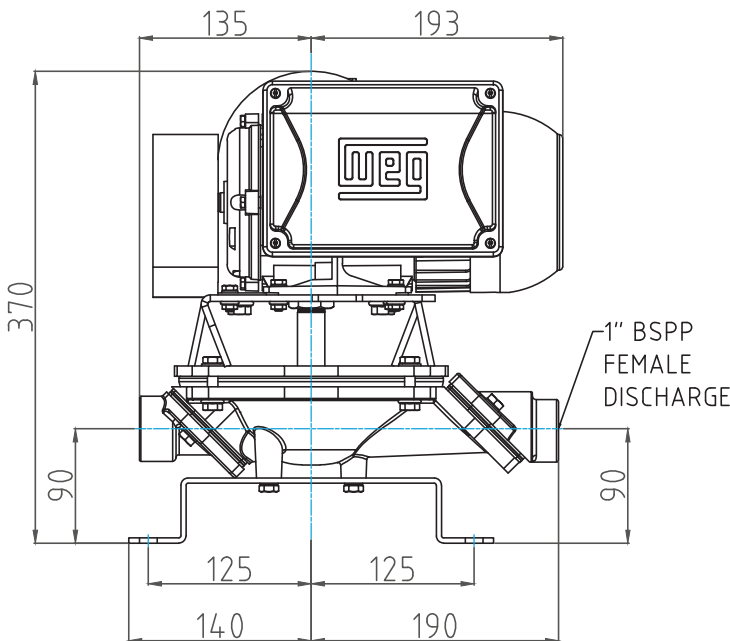

ASM PUMPS  
 14 Nicole Way, Dandenong South, Victoria, 3175  
 Ph: 03 9793 7577 Email: sales@asmpumps.com.au  
[www.asmpumps.com.au](http://www.asmpumps.com.au)

