



Petrol Engine Powered Pump Instruction Manual



BIA-WP10 - 804448

CONTENTS

1. Safety information	2
2. Location of warning labels	3
3. Name of components	4
4. Pre-starting operation	5-7
5. Starting the engine	7
6. Stopping the engine	10
7. Maintenance	11
8. Troubleshooting	13
9. Storage	13
10. Specifications	14
11. Spare Parts	16-17

Thank you for purchasing this Bianco Petrol engine pump.

This instruction manual describes the installation, usage and maintenance of the water pump and provides important safety information. Keep your manual in a convenient place for quick reference.

This manual should be considered as a permanent part of this water pump and should remain with the pump if it is sold.

Please take care of the information with following:

DANGER!

This indicates a hazardous situation which, if not avoided, will result in death or serious injury.

WARNING!

This indicates a hazardous situation which, if not avoided, could result in death or serious injury.

CAUTION!

This indicates a hazardous situation which, if not avoided, could result in minor or moderate injury.

IMPORTANT:

This indicates a potentially hazardous situation which, if not avoided could result in property damage.

NOTE:

This indicates useful information.

The warning and safety instructions appearing in this manual are not meant to cover all possible conditions and situations that may occur. Common sense, caution and care must be exercised when operating or cleaning tools and equipment. Always contact your dealer, distributor, service agent or manufacturer about problems or conditions you do not understand before operating the product.

WARNING!

1. Safety information

User's responsibility

- Before using this product, carefully read and fully understand this instruction manual for proper operation and safety procedures. Failure to follow all instructions may result in personal injury or product damage.
- Be sure that you are familiar with quick stop procedures and control operation of the water pump.
- This machine shall be operated by adults only! Keep children and pets away from the working area.
- This pump is designed to transfer clean water. Never attempt using this pump to deliver dirty water or slurry, or any inflammable or corrosive liquids.
- Do not touch the hot muffler while the machine is working . Move the machine when it's stopped and cooled down.
- To prevent fire hazards, keep at least 1 meter of clearance on all sides of this machine during operation.

DANGER!

Adding petrol

- Petrol is highly flammable and explosive. Always shut down this machine before refuelling. Refuel in a well-ventilated area. Make sure the filler cap is securely closed after refuelling.
- No smoking is allowed and no open fire or sparks allowed to exist in areas where fuelling is carried out or the fuel is stored.
- Be sure to remove the spilled petrol by wiping before starting this machine.

DANGER!

Carbon monoxide gas

- When in operation, the exhaust from this machine contains poisonous carbon monoxide gas. Breathing this poisonous gas can lead to eventual death. Use this machine **ONLY** outdoors in well-ventilated areas.

2. Location of warning labels

These warning labels indicate potentially hazardous situations which could result in serious injury. Please carefully read and understand the symbols, safety information and precautions.

The startup steps for gasoline engine:

1. Turn the engine switch to the ON position.
2. Press the priming bulb.
3. Close choke valve to the up.
4. Slightly raise the speed adjusting lever to the right (slightly throttle up the engine).
5. Pull the starting lever.
6. After successful startup, slowly open choke valve to the down.
7. Move the speed adjusting lever to the rightmost end (high speed).

Warning:
Fill up the water before starting the engine.

Label: Startup steps

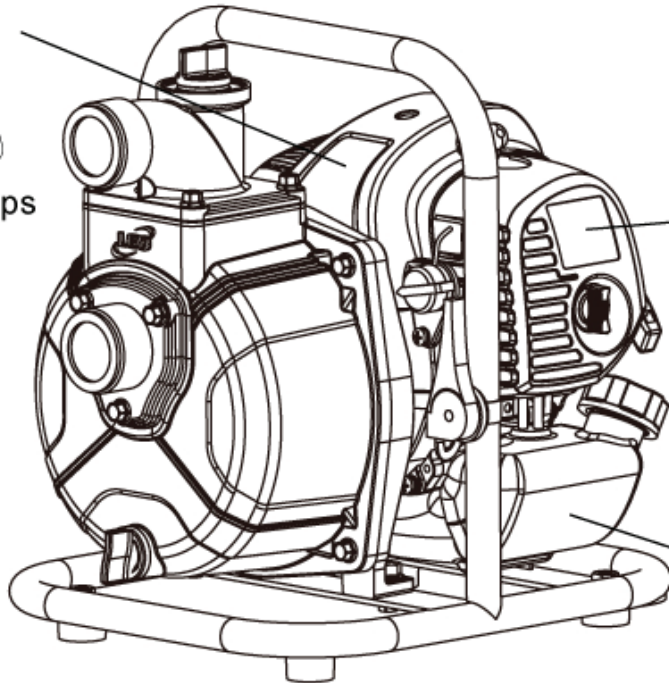

WARNING

- READ OWNER'S MANUAL BEFORE OPERATION.
- LIRE LE MANUEL D'UTILISATEUR AVANT USAGE.
- LEGGERE ATTENTAMENTE IL MANUALE DI USO E MANUTENZIONE PRIMA DELL'USO.
- VOR INBETRIEBNAHME UNBEDINGT BEDIENTUNGSANLEITUNG DURCHLESEN. NO UTILIZAR SIN ANTES NO.
- HABER LEIDO EL MANUAL. LEES HET INSTRUKTIEBOEKJE VOOR GEBRUIK.

Air cleaner label

Use mixture gasoline
Gasoline 25:1
Two-stroke
Engine Lubricate

Petrol mixture label



Model label

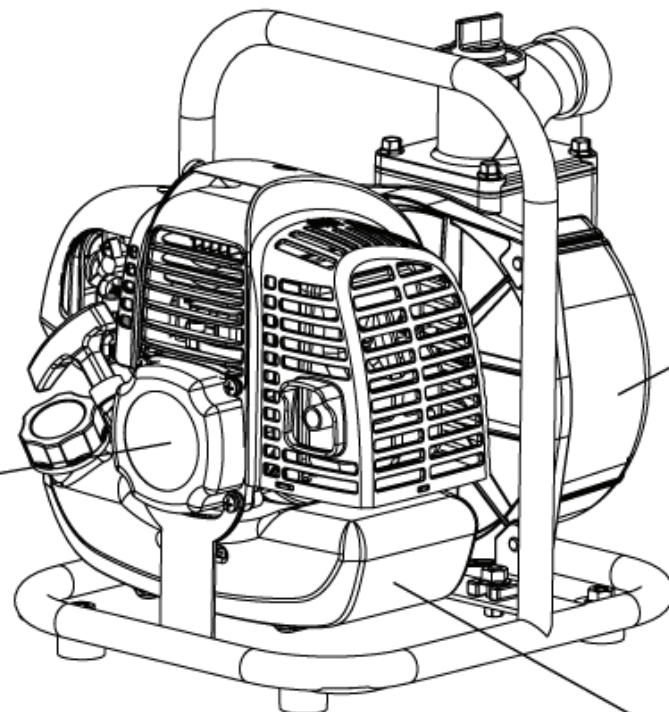

BIANCO PUMPZ SERIES 2		CE	
BIA-WP10		Petrol Engine Pump	
Qmax 100 l/min	Hmax 35 m		
Displacement 42.7cm ³ /1.6HP		Size 1"X1"	
RPM 7500	Date		
Distributed by: White International Pty Ltd Made in China			

Nameplate



Warning label

3. Components

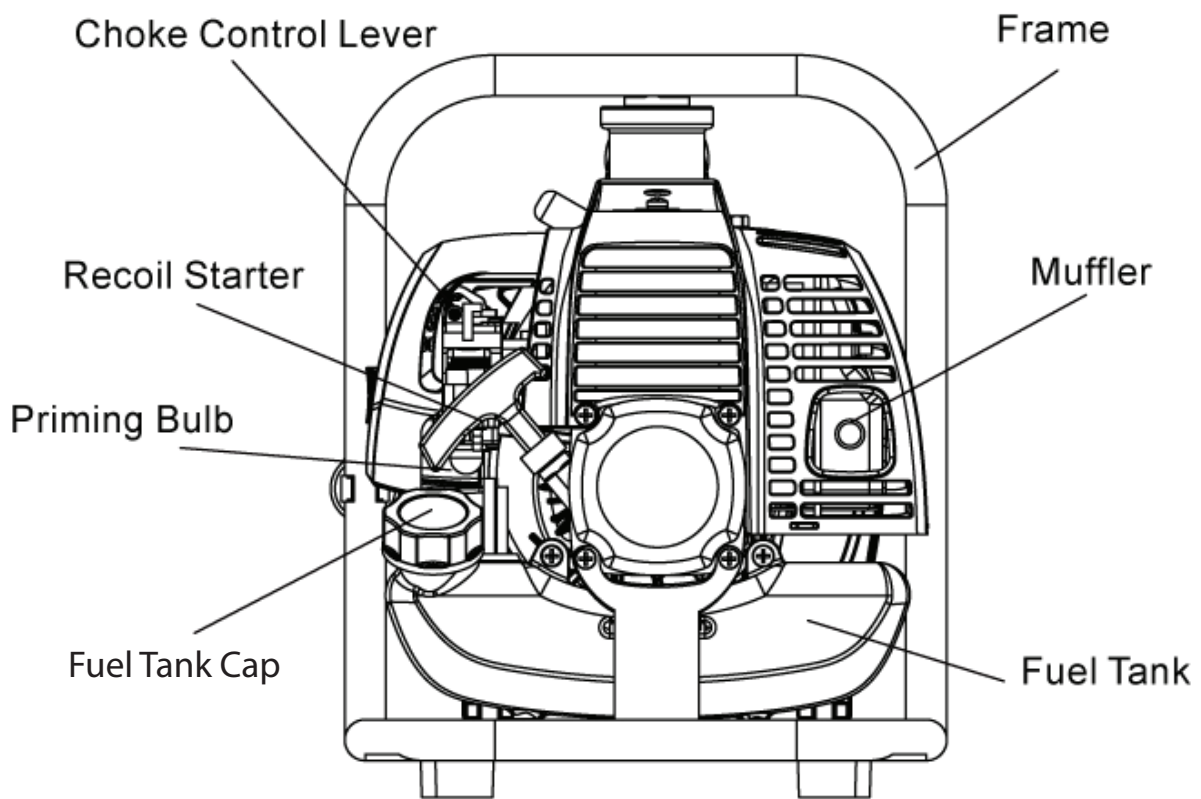
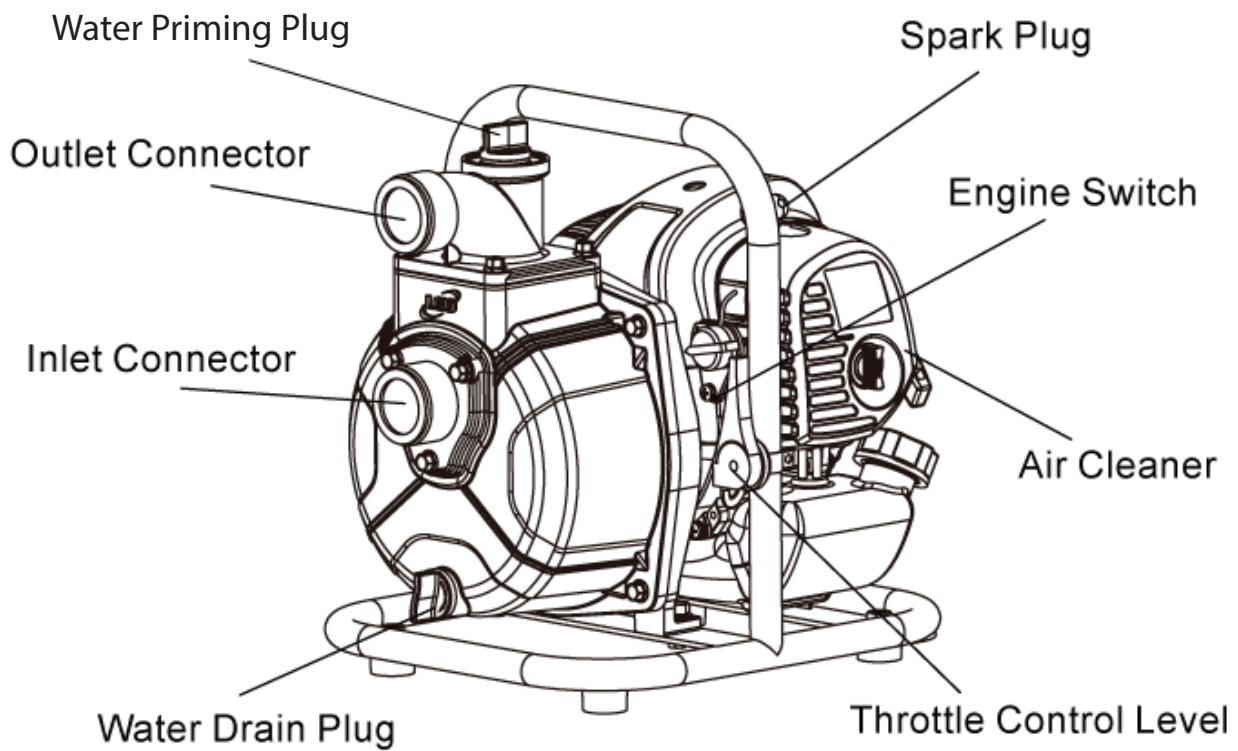

4. Pre-starting operation

IMPORTANT: Install the strainer on the end of the suction hose before operation. The strainer prevents foreign materials from entering the water pump and protects the pump from blocking and component damage.

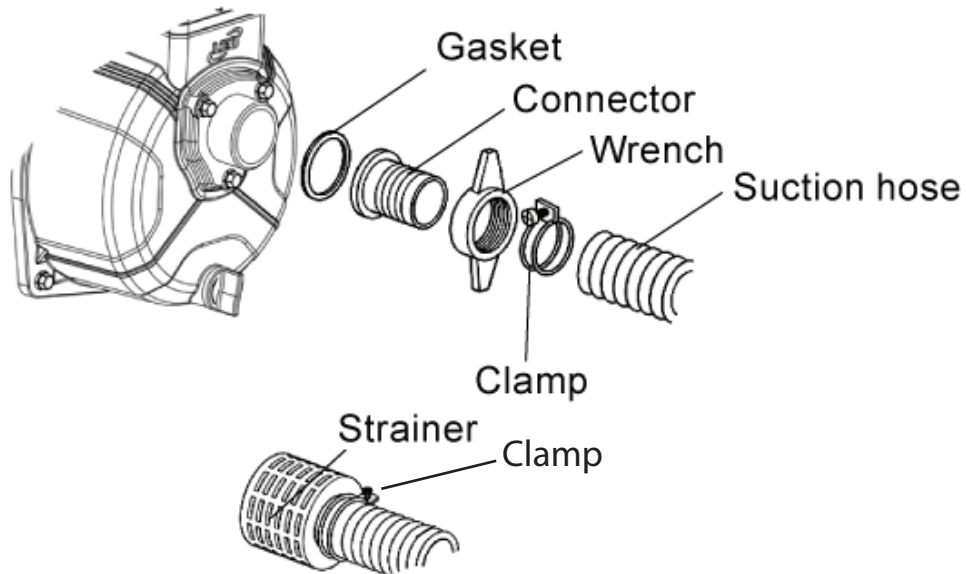

CAUTION!

To start this water pump, please check the following before each use:

- Confirm that petrol and oil mixture has been properly added.
- Confirm that water has been added to the pump housing.

Dry running will damage the mechanical seal.

Checking fuel level

Uncap the fuel tank and check the fuel level while the machine is not in operation. Add petrol and oil mixture if the fuel level is too low.

CAUTION!

Do not allow the fuel to overflow the fuel tank. Wipe up any spilled petrol with a dry cloth immediately.

Fuel Tank Capacity: 1 Litre

IMPORTANT:

Use an oil/petrol mixture of 2-stroke engine oil and automotive unleaded petrol with a Research Octane Number of 90 to 93.

NOTE:

How to use the ratio mixing container 25: 1

Add petrol to the line marked 576 ml and then add 2-stroke engine oil to the line marked 600 ml. Shake the container to mix liquids evenly.

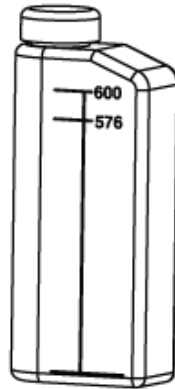

IMPORTANT:

- It is strictly prohibited to use 4-stroke engine oil.
- It is strictly prohibited to use only petrol.
- The carburettor or engine may not work properly in the case where mixed fuel has been left standing for more than one month.

Checking and filling the pump with water

The pump must be fully filled with water before it is put to operation.

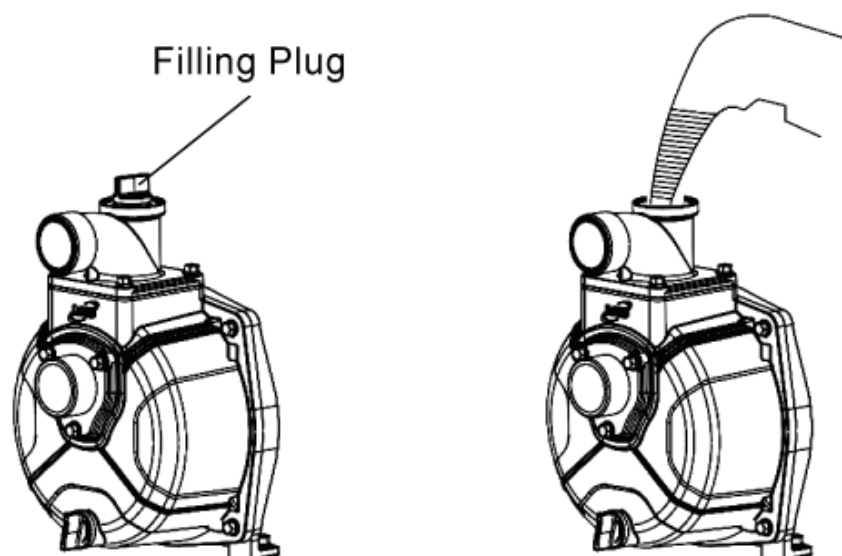

5. Starting the engine

CAUTION!

Confirm that the mixture of 2 stroke engine oil and unleaded petrol has been properly added to the fuel tank.

CAUTION!

Confirm that pump has been primed with water before starting.

1). Turn the engine switch to the ON position.

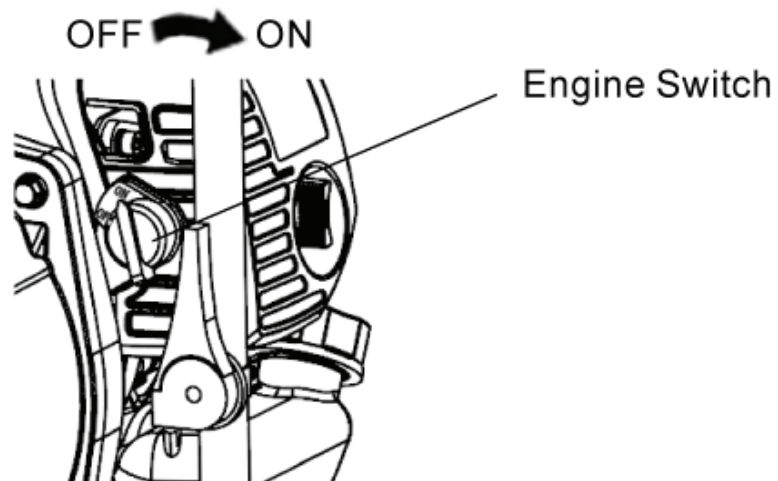

2). Press the priming bulb a few times until a fuel flow in the fuel return tube (clear plastic tube) is visually noticed

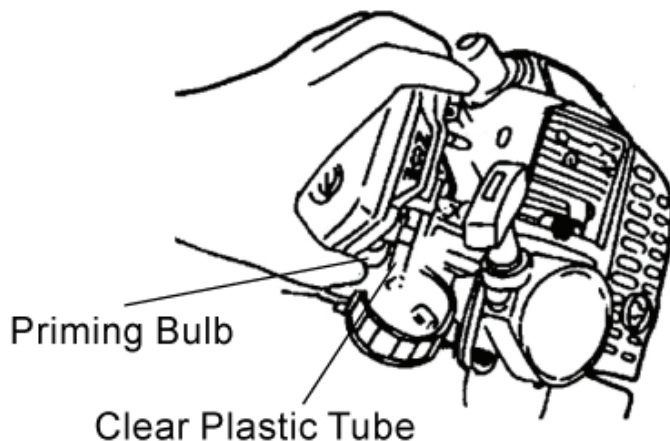

NOTE:

It's not necessary to press the priming bulb In case the engine is warm or fuel is found inside the clear plastic tube.

3). Move the choke control lever upward to the CLOSED position.

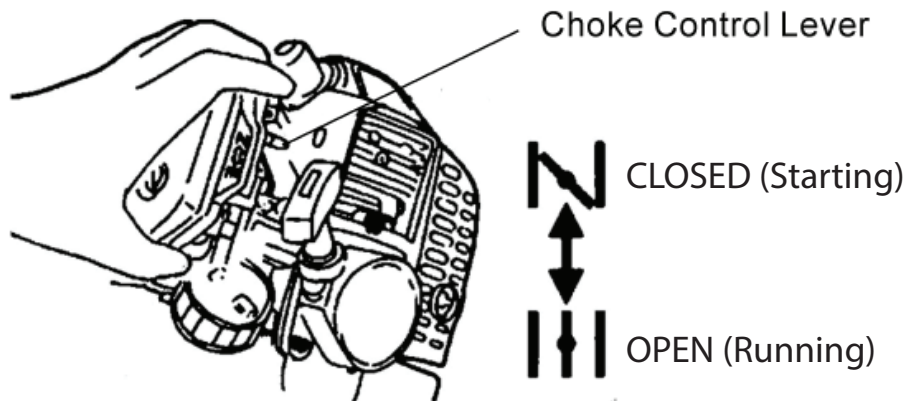

NOTE:

Do not use the choke if the engine is warm.

4). Move the throttle control lever away from the LOW position, about 1/3 of the way toward the HIGH position.

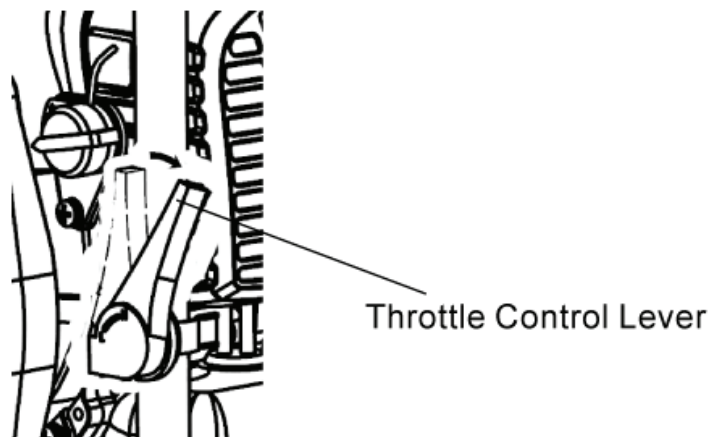

5). Pull the recoil starter lightly until a resistance is felt, then pull briskly.

CAUTION!

Do not allow the recoil starter to snap back against the engine. Return it gently.

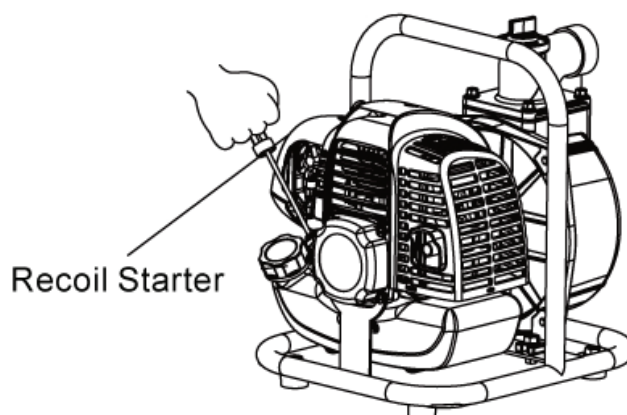

- 6). Move the choke control lever downward slowly to the OPEN position after the engine operates continuously.

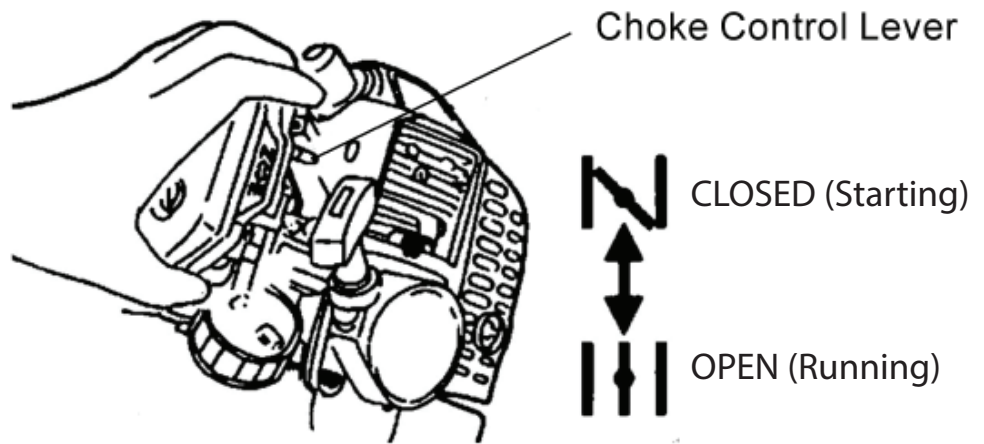

- 7). Move the throttle control lever to the HIGH position (right end).

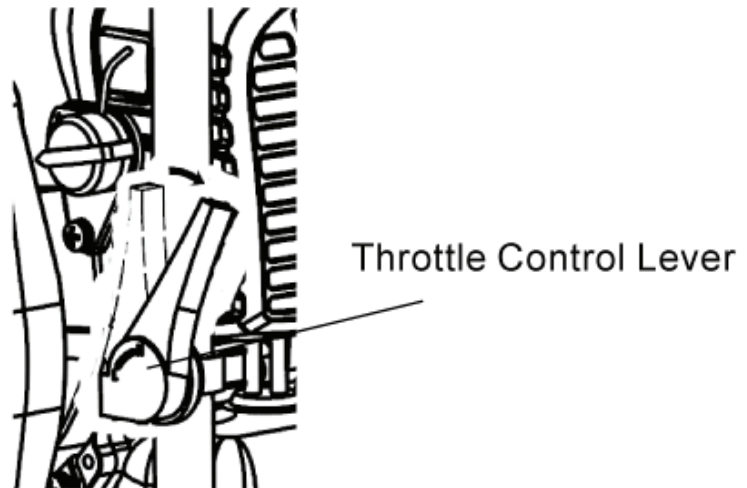

6. Stopping the engine

Please follow the steps below to stop the engine:

- 1). Move the throttle lever to the left end (low speed)

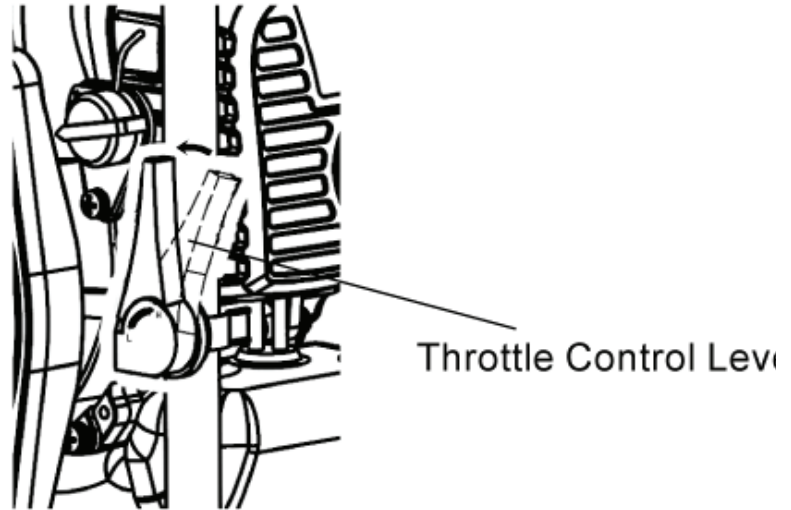

- 2). Turn the engine switch to the OFF position

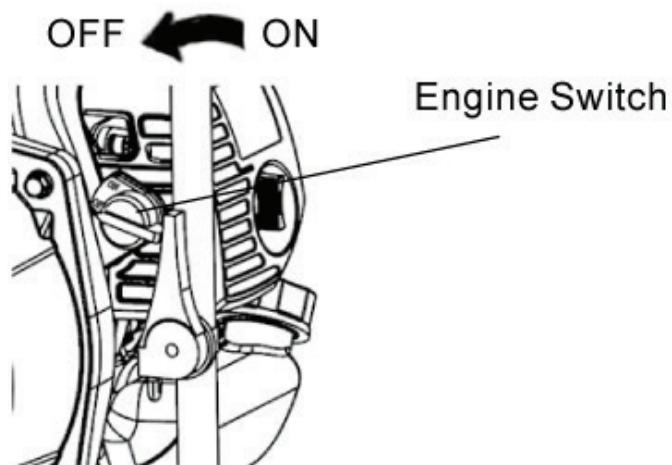

NOTE: Turn the engine switch to the OFF position immediately to shut down the engine in an emergency.

7. Maintenance

Maintenance Schedule

System or component		Maintenance	Before use	10 hrs or every 1 month	25 hrs or every 3 months	50 hrs or every 6 months	100 hrs or every year	Remarks
Engine	Spill of fuel	Cleanup	○					
	Fuel tank	Check & clean	○					Replace it if necessary
	Air cleaner	Check & clean		○				Replace it if necessary
	Fuel filter	Check & clean				○		Replace it if necessary
	Spark plug	Clean and adjustment of plug gap		○				Replace it if necessary
	Muffler	Clean					○	

NOTE: For commercial use, log hours of operation to determine proper maintenance intervals.

Maintaining the air cleaner

A dirty air cleaner will restrict air flow to the carburettor and result in less pump power. Service the air cleaner periodically to prevent carburettor malfunctions. More frequent maintenance will be necessary if the pump is working in an extremely dirty environment.

CAUTION!

Never run the pump without an air cleaner or with a damaged air cleaner. The dirt or dust if sucked into the engine may quicken engine wear.

- 1). Move the choke control lever upward to the CLOSED position to prevent dust and dirt from the carburettor.
- 2). Unscrew the wing nut and remove the air cleaner cover.
- 3). Separate filter element from foam element.
- 4). Replace the element if damaged. Replace the paper filter element in accordance with maintenance schedule.

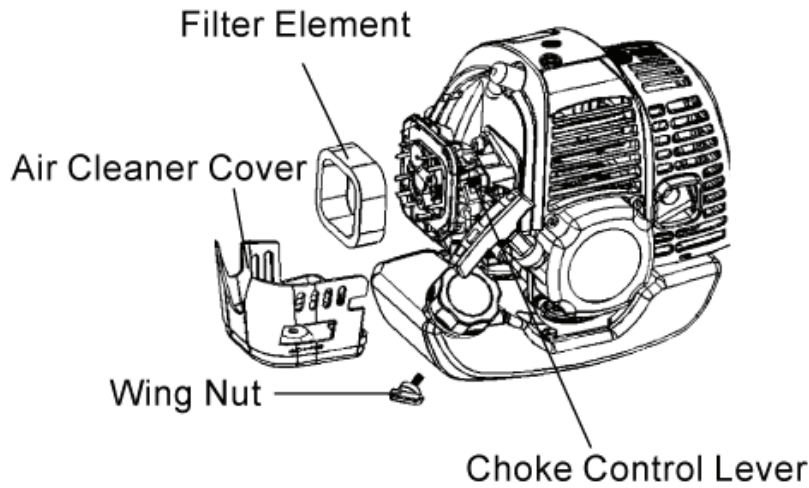

Cleaning filter element:

Slightly tap the filter element a few times, then blow it with compressed air (pressure ≤ 207 K Pa) from inside. Do not clean the filter element with brush, which will block the air passages of the element.

Cleaning foam filter element:

Wash the element in hot water with detergent or in a non flammable or high flash point solvent. Let it dry thoroughly and immerse it into clean oil and then squeeze out the excess oil.

- 5). Clean the lower part of air cleaner, air cleaner cover and rubber gasket.
- 6). Combine the filter element and foam filter element.
- 7). Reinstall the air cleaner element and the cover.

Maintaining the fuel filter

An unclear fuel filter may cause low or unstable engine speed.

- 1). Remove the fuel tank cover.
- 2). Take the fuel filter out of the fuel tank.
- 3). Check the fuel filter. Replace it if damaged.

Cleaning the fuel filter

The fuel filter can be rinsed in hot water with detergent or can also be cleaned in non-inflammable or high-flash-point solvent. Dry it and put it back into the fuel tank.

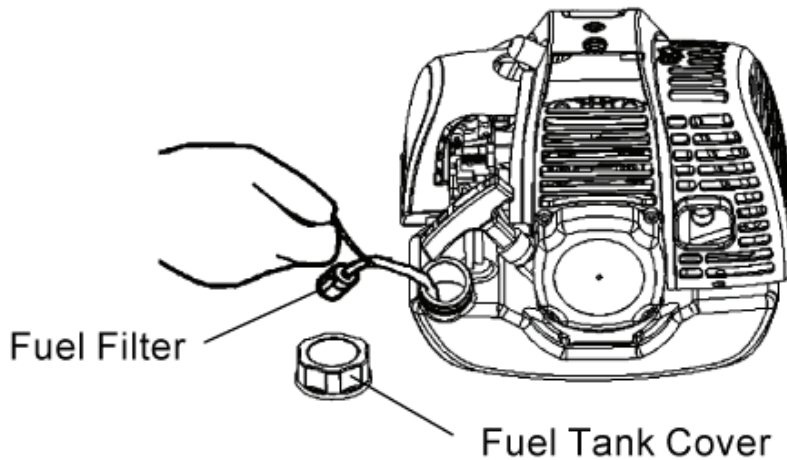

Maintaining the spark plug

The recommended type of spark plug is L7RTC (TORCH) or equivalent.

CAUTION!

Take care not to touch the muffler due to high temperature on its surface when removing or installing the sparkplug.

- 1). Remove the plug cap.
- 2). Remove the spark plug with the wrench.
- 3). Visually check the spark plug. Discard it if the electrode or insulation ring is damaged or the insulator is broken or cracked. Check the plug gap with a feeler gauge. The gap should be 0.60 - 0.70 mm. Vary the gap by moving the side electrode if necessary.
- 4). Clean sparkplug thread and cylinder thread of any dirt before assembly. Caution, do not drop dirt or debris into cylinder head.
- 5). Thread the plug in by hand to prevent cross-threading.
- 6). Tighten the spark plug with the wrench to compress the washer by turning a further 1/4 turn.
- 7). Reinstall plug cap.

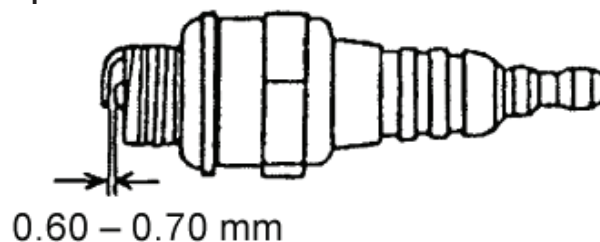

8. Troubleshooting

The engine will not start:

- 1). Is the fuel type correct? (2 stroke oil & unleaded fuel)
- 2). Is there enough fuel?
- 3). Has the fuel reached the carburettor?
- 4). Is the fuel air cleaner blocked?
- 5). Is the spark plug generating sparks?
Remove and check the spark plug, clear off the dirt from around the plug and dry it. Fit the spark plug into the plug cap. Replace the spark plug if necessary.
- 6). If the engine still refuses to get started, contact an authorized dealer.

The pump does not pump water:

- 1). Is it primed with water?
- 2). Is the strainer clogged?
- 3). Is the hose clamp tightened?
- 4). Is the suction hose damaged?
- 5). Is the suction head too high? (must be less than 8m)
- 6). If the pump still fails to work, contact an authorized dealer.

9. Storage

Let the pump cool down. Wait at least 30 minutes after it stops. Clean the pump and coat with rust-proof grease if necessary.

CAUTION!

Do not clean with water under pressure that may go into air filter and muffler, or even go into cylinder which will result in corrosion damage.

Before storing the pump for a long time:

- 1). Make sure the storage area is free of moisture and dust.
- 2). Drain off the fuel.
 - a. Drain the fuel in the fuel tank into a suitable container.
 - b. Press the priming bulb and drain the fuel inside carburettor into the fuel tank.
 - c. Drain the fuel in the fuel tank again after the fuel inside carburettor is drained off.
- 3). Remove the spark plug.
- 4). Put 2 ml of clean 2-stroke engine oil into cylinder.
- 5). Pull up the recoil starter two or three times to distribute the oil inside the cylinder.
- 6). Reinstall the spark plug.
- 7). Pull up the starter until a resistance is felt. In this case, both the inlet valve and outlet valve is closed to prevent corrosion inside the engine.
Let the starter recoil slowly.
- 8). Cover the pump to keep dust out.

10. Specifications

Model	BIA-WP10
Dimensions and Weight	
Total length	350 mm
Total width	290 mm
Total height	325 mm
Dry weight	8 kgs

Engine

Model	G43
Engine type	Single cylinder, 2-stroke, forced air-cooled
Displacement (Bore X Stroke)	42.7 cc (40 × 34 mm)
Ignition system	CDI
Rotation direction	Counterclockwise
Idle speed	3000 rpm
Fuel tank capacity	1 L
Mixture ratio	25:1 (2-stroke engine oil and 90 octane gasoline or higher.

Pump

Inlet diameter	25 mm	1" BSPM
Outlet diameter	25 mm	1" BSPM
Maximum head	35 m	
Maximum suction	8 m	
Maximum flow	100 l/min	
Self-priming time at 5 m	≤120 s	

NOTE: Specifications are subject to change due to technical improvements without prior notice.

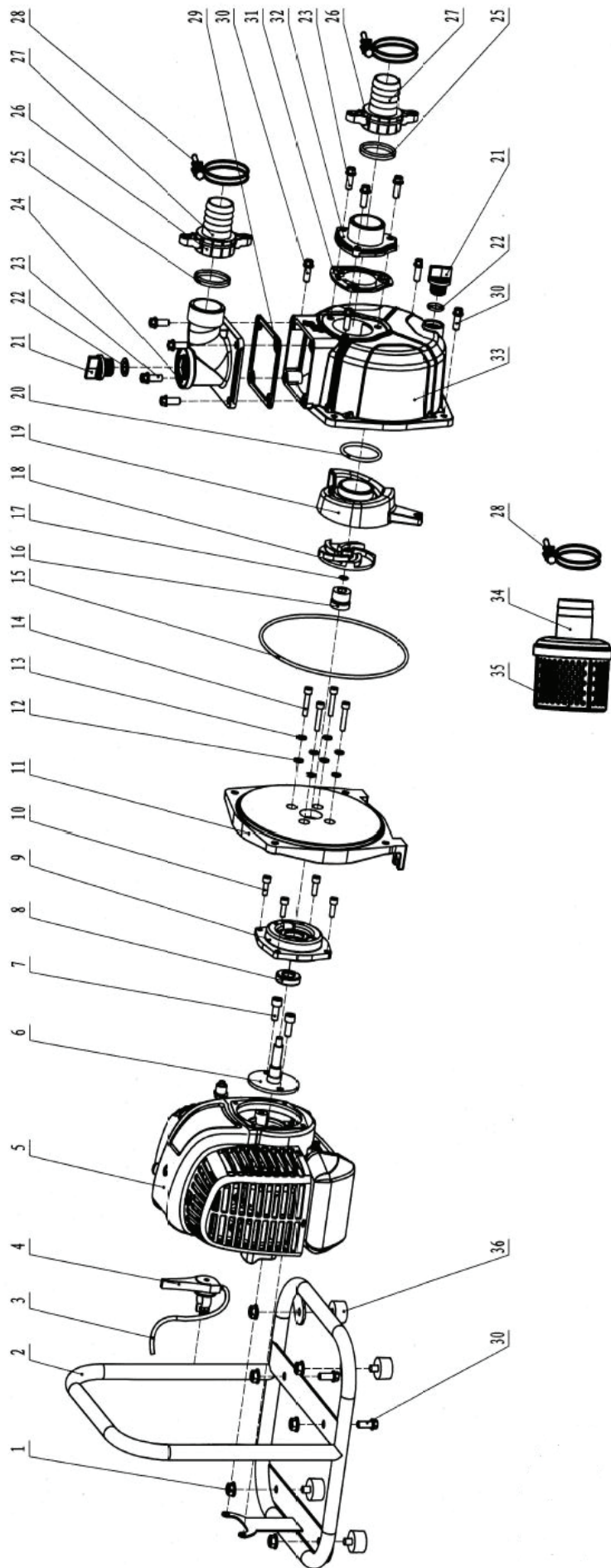

11. Spare Parts

	BIA-WP10					
POS.	PART NO.	DESCRIPTION	POS.	PART NO.	DESCRIPTION	
1	BIA-WP10-1	HEX NUT M8	19	BIA-WP10-19	DIFFUSER	
2	BIA-WP10-2	FRAME	20	BIA-WP10-20	O RING 42X4.15	
3	BIA-WP10-3	CABLE ASSY	21	BIA-WP10-21	PLUG	
4	BIA-WP10-4	THROTTLE TRIGGER	22	BIA-WP10-22	O RING 15.8X3.1	
5	BIA-WP10-5	ENGINE	23	BIA-WP10-23	HEX BOLT M6X20	
6	BIA-WP10-6	STUB SHAFT	24	BIA-WP10-24	OUTLET	
7	BIA-WP10-7	SOCKET SCREW	25	BIA-WP10-25	GASKET	
8	BIA-WP10-8	BALL BEARING	26	BIA-WP10-26	SPANNER	
9	BIA-WP10-9	FLANGE	27	BIA-WP10-27	PIPE	
10	BIA-WP10-10	HEX SCREW M6X18	28	BIA-WP10-28	CLAMP	
11	BIA-WP10-11	PUMP COVER	29	BIA-WP10-29	OUTLET SEAL	
12	BIA-WP10-12	WASHER 6.4X12X1	30	BIA-WP10-30	HEX BOLT M8X20	
13	BIA-WP10-13	WASHER	31	BIA-WP10-31	NON RETURN VALVE	
14	BIA-WP10-14	SOCKET SCREW	32	BIA-WP10-32	INLET	
15	BIA-WP10-15	O RING 159X4	33	BIA-WP10-33	PUMP BODY	
16	BIA-WP10-16	MECHANICAL SEAL	34	BIA-WP10-34	STRAINER FITTING	
17	BIA-WP10-17	WASHER	35	BIA-WP10-35	STRAINER	
18	BIA-WP10-18	IMPELLER	36	BIA-WP10-36	RUBBER FEET	



2 YEAR WARRANTY



White International Pty Ltd
Limited Product Warranties
TERMS & CONDITIONS

This warranty is given in addition to the consumer guarantees found within the Australian Competition and Consumer Act 2010 (Cth) for goods purchased in Australia and the Consumer Guarantees Act 1993 NZ for goods purchased in New Zealand:

1) White International Pty Ltd / White International NZ Ltd (White International) warrant that all products distributed are free from defects in workmanship and materials, for their provided warranty period as indicated on the top or opposite side of this document. Subject to the conditions of the warranty, White International will repair any defective products free of charge at the premises of our authorised service agents throughout Australia and New Zealand if a defect in the product appears during the warranty period. If you believe that you have purchased a defective product and wish to make a claim under this warranty, contact us on our Sales Hotline on 1300 783 601, or send your claim to our postal address or fax line below and we will advise you as to how next to proceed. You will be required to supply a copy of your proof of purchase to make a claim under this warranty.

2) This warranty excludes transportation costs to and from White International or its appointed service agents and excludes defects due to non-compliance with installation instructions, neglect or misuse, inadequate protection against the elements, low voltage or use or operation for purposes other than those for which they were designed. For further information regarding the suitability of your intended application contact us on our Sales Hotline on 1300 783 601. If you make an invalid claim under this warranty, the original product will be sent back to you unrepaid.

3) This warranty refers only to products sold after the 1st January 2012, and is not transferable to another product type and only applies to the original owner, purchaser or end user, and is in addition to the consumer guarantees found within the Competition and Consumer Act 2010 (Cth) for goods purchased in Australia and the Consumer Guarantees Act 1993 (NZ) for goods purchased in New Zealand.

4) Our goods come with guarantees that cannot be excluded under the Australian Consumer Law. You are entitled to a replacement or refund for a major failure and for compensation for any other reasonably foreseeable loss or damage. You are also entitled to have the goods repaired or replaced if the goods fail to be of acceptable quality and the failure does not amount to a major failure.

5) To the fullest extent permitted by law, White International excludes its liability for all other conditions or warranties which would or might otherwise be implied at law. To the fullest extent permitted by law, White International's liability under this warranty and any other conditions, guarantees or warranties at law that cannot be excluded, including those in the Competition and Consumer Act 2010 (Cth), is expressly limited to:

(a) in the case of products, the replacement of the product or the supply of equivalent product, the payment of the cost of replacing the product or of acquiring an equivalent product or the repair of the product or payment of the cost of having the product repaired, is at the discretion of White

International or a 3rd party tribunal elected under the Competition and Consumer Act 2010 (Cth) for goods purchased in Australia and the Consumer Guarantees Act 1993 (NZ) for goods purchased in New Zealand; and

6) To the fullest extent permitted by law, this warranty supersedes all other warranties attached to the product or its packaging.

7) In the case of services, supplying the services again or the payment of the cost of having the services supplied again, is at the discretion of White International or a 3rd party tribunal elected under the Competition and Consumer At 2010 (Cth) for goods purchased in Australia and the Consumer Guarantees Act 1993 (NZ) for goods purchased in New Zealand.

8) Our warranty commences from the date of purchase of the above mentioned pumps. Proof of purchase is required before consideration under warranty is given. Record your date of purchase in the space below and retain this copy for your records.

Date of Purchase

Model Purchased

WHITE INTERNATIONAL PTY LTD

60 Ashford Ave Milperra NSW 2214
PO Box 304 Milperra LPO NSW 2214
Customer Service Hotline 1300 783 601
Fax 02 9783 6001
Email Sales: pumpsales@whiteint.com.au
www.whiteint.com.au

WHITE INTERNATIONAL NZ LTD

15G Kerwyn Avenue
East Tamaki, Auckland 2013, New Zealand
Customer Service Hotline 0800 509 506
Customer Service Faxline 0800 804 344
Email Sales: sales@whiteint.co.nz
www.whiteint.co.nz

P_P_BI_IM_804448