



Single Pump Protection and Control Module

BIA-nXt-Protect 3-40 PN 811203

BIA-nXt Protect 3-11 PN 811204

Installation and Operation Manual

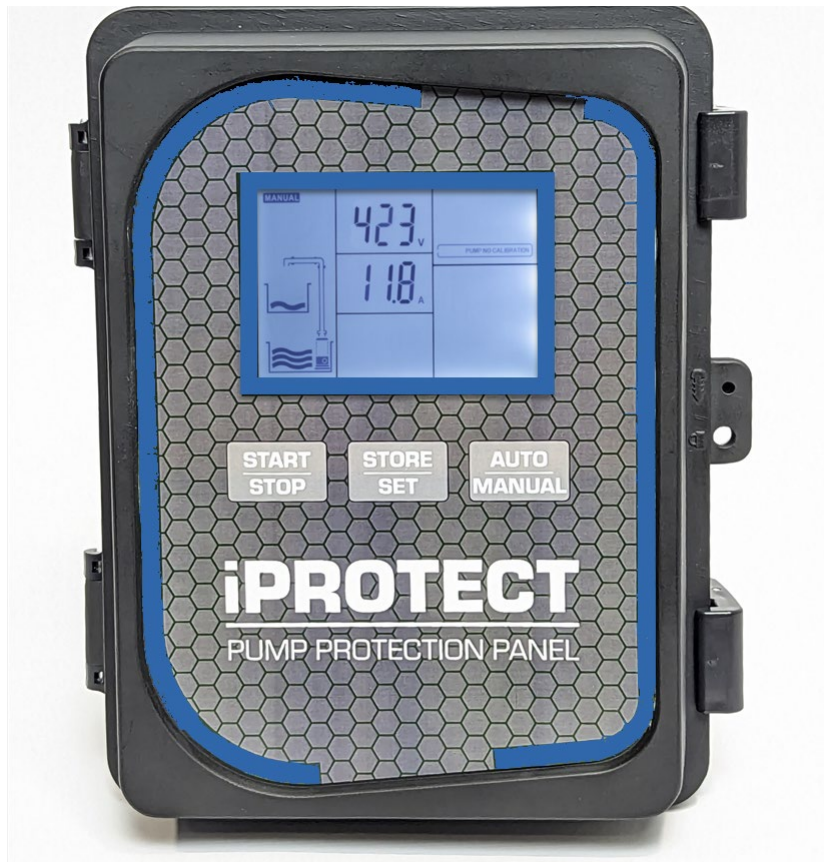

A. Shortcuts

Switching between AUTO and MANUAL:

Hold the **AUTO/MANUAL** button for 5 seconds.

Accumulated Run time:

Controller in manual state.

Press and hold **STORE/SET** and **START/STOP** together

Error log:

- Switch to MANUAL mode
- Ensure no pumps are running.
- PRESS and HOLD the **AUTO/MANUAL** button, for 5 seconds

Alarm Mute:

At any time press the **START/STOP** button to mute the alarm. It will now beep every 5 minutes

Alarm Test:

In manual mode PRESS and HOLD the **STORE/SET** button for 3 seconds

B. Shortcuts cont

Calibrating the controller to the pump

In manual mode, short press **START/STOP**. Allow the pump to run and the current draw to stabilise.

Once you are satisfied the pump is in its 'normal' operating range a short press of the **STORE/SET** button will cause the controller to chirp indicating success.

The controller calibration values can be entered **Parameter #001 - 003 Pg 13**

To clear the calibration

With the pump stopped and the controller in manual mode, PRESS and HOLD the **START/STOP** button for 30 seconds

Auto calibration will populate parameters 001 as 70%, 002 as 140%, 003 as 170%.

These may be manually altered in the programming menu

Programming menu

In manual mode, with no pump running, press the **STORE/SET** button for 5 sec.

Page 13

Programming:

START/STOP increases a value

AUTO/MANUAL decreases a value

Press **STORE/SET** to proceed through the parameter menu

Long press **STORE/SET** to store all changes and exit

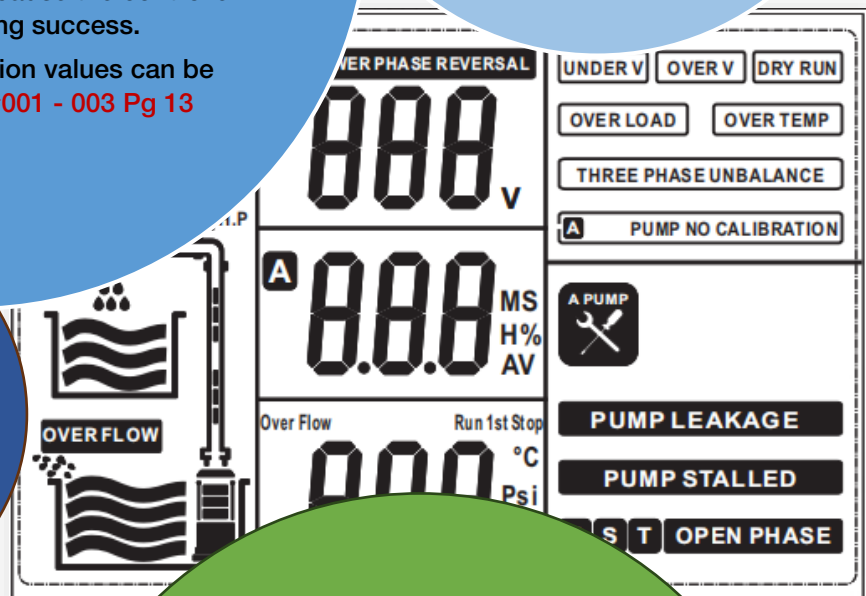

1. Introduction

Thank you for choosing a Bianco nXt-Protect single pump control and protection module. The Bia nXt-Protect is a module intended to control and protect an individual three phase pump. The user can select a control logic sequence to match their application and enjoy the benefits of superior control and protection for the pumps.

There are 3 primary control logic modes:









- 'Drainage' where control is concentrated at the source
- 'Boosting' which references pressure switching on the delivery side for control
- 'Transfer' which is a mix of source and destination control

The LCD screen displays the pump running state and provides the user a wealth of useful information.

The controller is easy to set up with an initial push button calibration and individual parameters can be fine-tuned.

A nXt-Protect controller is particularly useful where there is the need to control and protect pump installations managing the automatic operation through a variety of switching methods without the need to create a bespoke control solution.





2. Warnings and Cautions

	Read the manual carefully before starting
 	Prior to starting installation or maintenance the controller must be disconnected from the power supply.
	Any changes or modification to the wiring must be carried out by competent, skilled and suitably qualified personnel only.
	A qualified electrician should correctly size and install circuit breakers to protect the power supply. The fitment of additional surge protection is recommended as good practice.
	Never open the cover while controller is connected to electrical supply. Disconnect and allow the internal electronics to discharge before opening the cover
	This appliance is not intended for use by persons (including children) with reduced physical, sensory or mental capabilities, or lack of experience and knowledge, unless they have been given supervision or instruction concerning use of the appliance by a person responsible for their safety. Children should be supervised to ensure that they do not play with the appliance.
	Ensure the controller is a suitable size for the pump motor (see Section 6, Page 7: Technical Data). Size according to full load current amperage.(P1 power)

3. Contents

A. Shortcuts	2
1. Introduction	4
2. Warnings and Cautions	4
3. Contents	5
4. ISO 7010 Symbols used in this manual	5
5. Modes of Operation.....	6
6. Technical Specifications	7
7. Display	8
8. Electrical Connections.....	10
9. Parameter Calibration.....	11
10. Program Parameters	12
11. Quick guide: Transfer – source/destination control.....	14
12. Quick guide: Drainage Mode, float connected to pump.....	15
13. Quick guide: Drainage Mode, external control inputs.....	16
14. Quick guide: Pressure Boosting.....	17
15. Quick guide: Sensorless Time control.....	18
16. Fault Messages	19
17. Warranties – Terms and Conditions	20

4. ISO 7010 Symbols used in this manual

	Warning - Electrical safety
	Warning – Potential consequences of use outside of intended application(s). Includes environmental condition warnings.
	Mandatory warning
	Warning to disconnect power
	Read carefully





5. Modes of Operation



On the main PCB there is a 2 position 'Dip Switch'

To alter the control logic to suit an application, the installer must select the appropriate switch position.

After selecting the desired switch position, **cycle the controller power to apply the setting.**

Binary	Switch position	Control logic - Applications
1		'Drainage' Mode where the level control input is managed by a flexible float on the pump.
2		'Pressure Boosting' Mode. Main control via (N/C) pressure switch. Supports run / no run level protection at the source via floats or probes.
3		'Drainage' Mode where the control inputs (generally level floats or probes) are located at the source.
4 Default Mode		'Transfer' Mode. Main control via control inputs (floats or probes) at destination or by a pressure switch on the delivery line. Supports run / no run level protection at the source.
4		Sensorless time control

When first powered on the nXt-Protect will display the current dipswitch operating mode (binary code), the hardware and the software version.

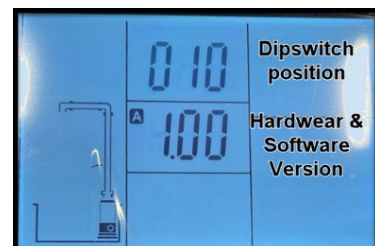

6. Technical Specifications

Controller Modes	Automatic or Manual pump operation. Liquid level control via float switch or electrode probes. Pressure control via pressure switch.
Protection functions:	Dry run (Underload), Overload, Pump Stalled, Open and reverse phase, Under voltage, Over voltage, Short circuit, Pump Maximum run time
Input Voltage	415V +10% -6%
Rated output power	Protect 3-40 nominal 0.37 to 4 kW P2 power (max 12A input) Protect 3-11 nominal 2.2 to 11 kW P2 power (max 25A input)
Minimum input current	1.0 amp to achieve calibration successfully
Working temp	-25 to +55 deg C 20% to 90% relative humidity, non-condensing
Controller size	200mm wide, 275mm tall, 125 deep. IP54
Trip response times (set)	Open phase – Less than 2 sec Short circuit – less than 0.1 sec
Trip Voltage (User adjustable)	Over voltage – Default = 460V Under voltage – Default = 340V
Trip response times (User adjustable)	Dry run (Under-load) 3 sec Under Voltage Less than 5 sec Over voltage Less than 5 sec
Recovery times (User adjustable)	Dry run (Under-load) 30 min default Overload 30 min default Under Voltage 5 min default Over voltage 5 min default
Alarms	Audible alarm and flashing screen



To avoid 'nuisance' alarming, many of the default protection parameters have values with a wide tolerance. The installer is encouraged to optimise the settings to achieve optimum results

7. Display

The nxt-Protect display provides a real time indication of the operational mode and the current state of the controller, including real-time voltage/current and any error messages.

Only the icons relevant to the selected operational mode will display.

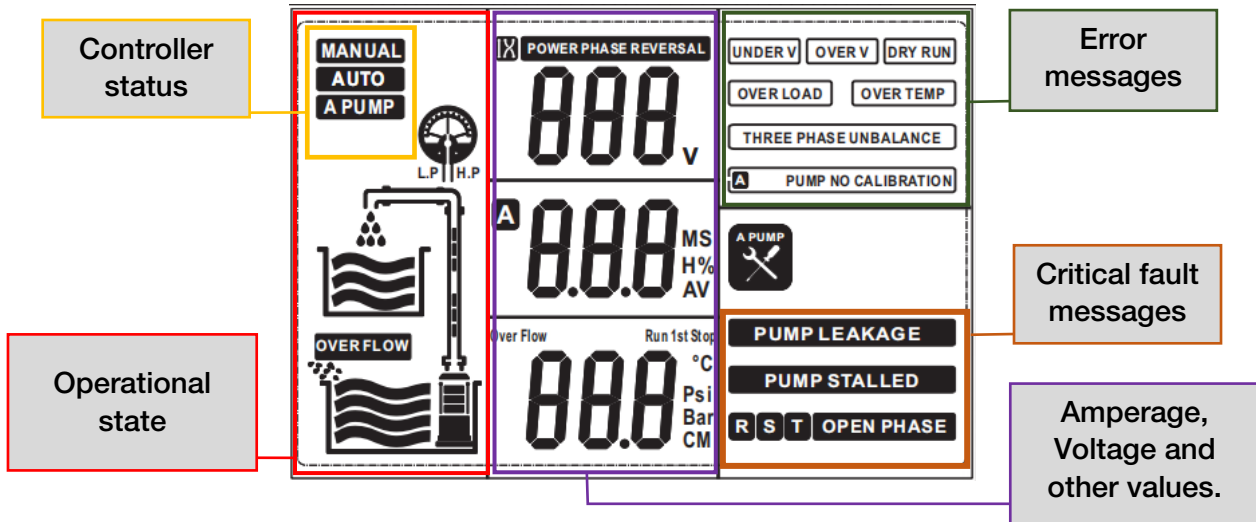

Flashing screen provides visual alarm indication

Current monitoring

Audible alarm

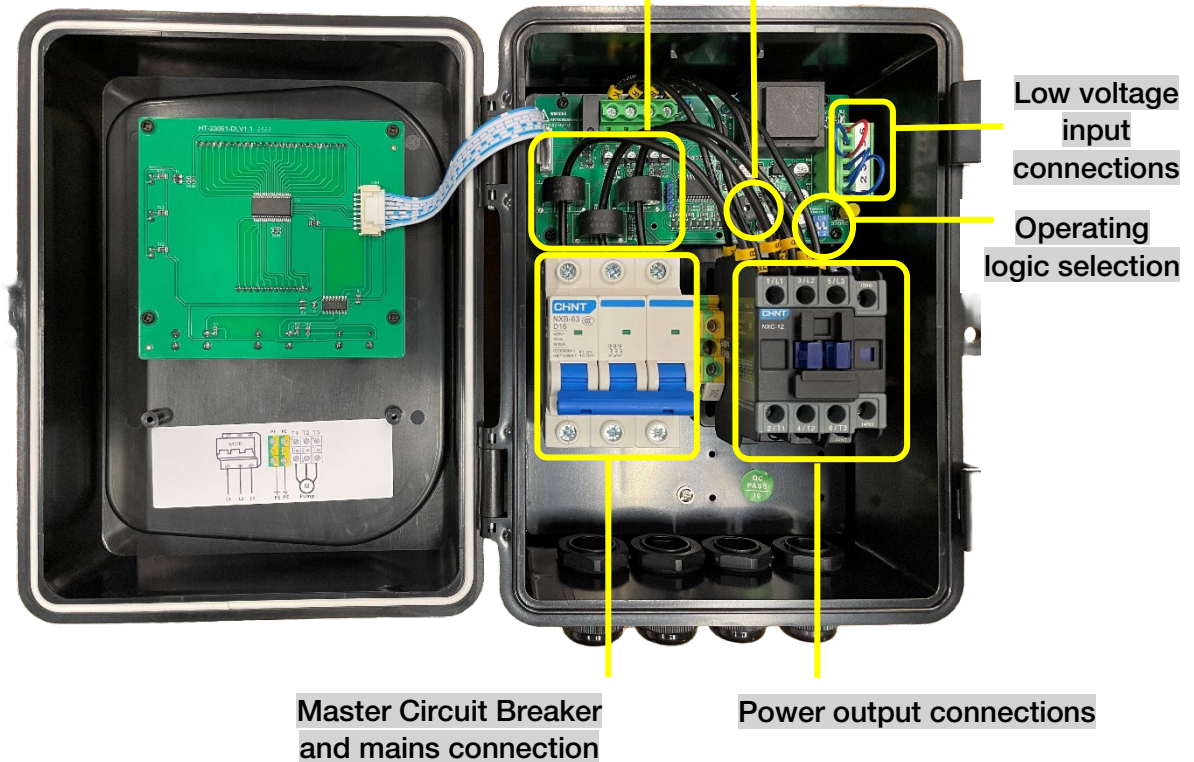





7. Display con't

The nXt-Protect controller operates according to pre-programmed logic applied to each 'mode'.

Changing the Dip Switches inside the controller then **cycling the power** will activate the selected logic mode.

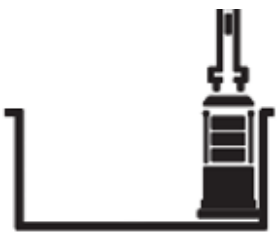
Examples of common applications are detailed later in this manual but with an understanding of how the controller responds to various inputs in each of the modes the controller can be used for application other than what is suggested.

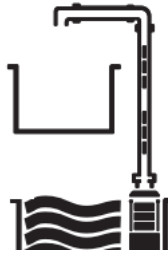
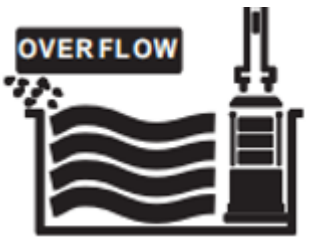
The appearance of the front display changes according to each mode and provides a visual indication to the state of the input signals.

	Lack of source water		High pressure Low pressure
	Source water full		Destination low
	Overflow		Destination full

Avoid installing the nXt Protect where it could experience the following conditions:

- i. Where there is significant vibration and/or mechanical shock.
- ii. Where it could be exposed to corrosive liquids or gasses, or to flammable materials, solvents etc.
- iii. Extreme heat and cold. Operating range -25°C - 55°C.
- iv. Protect the controller from rain, moisture, humidity or dust

8. Electrical Connections

Always use an electrical outlet that is protected by Residual Current Device (RCD) Safety Switch with a trip current of 30mA or less. A Safety switch is required by Australian/New Zealand Standard AU/NZS 60335.1-2011.



All high voltage wiring must be connected by a suitably qualified technician.

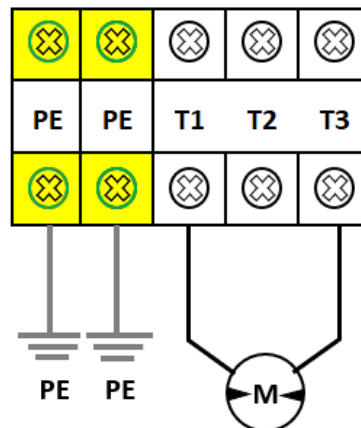
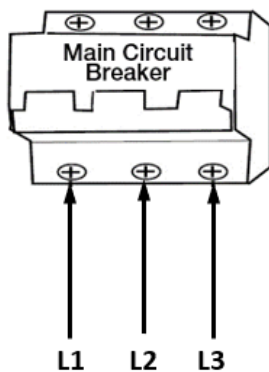

It is the responsibility of the installing electrical technician to ensure that the cable cross section (mm²) meets the requirements of AS/NZS 3008; taking into consideration the cable type, the cable length, the current draw and other relevant factors.

If in doubt online resources exist i.e. Cable Size Calculator AS/NZS 3008 or seek advice from an electrical engineer or other suitably qualified person(s)

Note that nXt-Protect is intended to control a standalone single pump only.
If the user wishes to connect to a BMS or to operate an external alarm enquire about nXt SPC/DPC controllers

9. Parameter Calibration



The pump must be able to pump water to enable correct calibration. Calibrated without water, overload and pump stalled errors may occur later.

Calibration can be performed automatically as detailed in the installation guides Page 3. Alternately the user can enter Underload, Overload and Pump Stalled Amperages.

Always perform a fresh calibration after installing a new pump, or when reinstalling an existing pump following maintenance.

Either erase the existing calibration or manually program Parameters 1 -3.

The controller operation is managed using the buttons on the front cover and a sequence of short, long and combination button presses.



To access parameter settings the controller should be in its **Manual** operational mode and the pump should NOT be running.

Press and hold **STORE/SET** for **5 sec** to enter the parameter menu.

To enter a parameter, press the **STORE/SET** button. This will display the current value for the parameter.

- Press the **START/STOP** button to increase a value.
- Press the **AUTO/MANUAL** button to decrease a value.

To store the value and return to the main menu press **STORE/SET** button.

To store all changes and exit the parameter menu hold the **STORE/SET** button for **5 sec**

Pump current draw MUST be greater than 1 amp for Auto Calibration to be successful.

Full factory reset

- Turn off power to the control panel,
- Press and hold START/STOP as the power is turned on
- When the display shows 099, release the START/STOP button.

10. Program Parameters

Press  to switch between AUTO and MANUAL mode

The controller operating mode will be displayed in the top left corner of the display

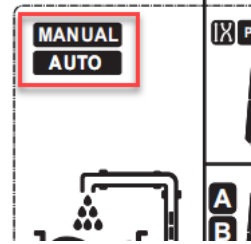

ITEM	DEFAULT	OPERATION
001	0.0 A	Dry run protection trip amperage: Auto config to 70% of calibration value
002	26 A	Over load protection trip amperage: Auto config to 140% of calibration value
003	33.1 A	Pump stalled trip amperage: Auto config 170% of calibration value
The user may manually tune parameters 001, 002 and 003 to alter the auto configuration values		
004	352V	Under voltage trip voltage
005	476V	Over voltage trip voltage
006	6 sec	Dry run protection trip response time: range 0 – 254 sec
007	30 min	Dry run protection recovery time: range 0 – 254 min
008	00	Timer control (auto mode) – Parameters 009 – 101 00 = inactive 01 = active
009	5 min	Pump run timer: range 0 – 254 min
010	5 min	Pump Stop timer: range 0 – 254 min
011	0 min	Pump stop time (manual mode): range 0 – 254 min
012	5 min	LCD backlight timeout: range 0 – 254 min
013	00 min	Maximum run time alarm in Boosting mode: range 1 – 254 min
014	00	Button Lock – set to 01 to activate Manual/Auto and Store buttons to unlock
015	ON	Open Phase Protection When using the nXt SPC in conjunction with a VFD set to OFF
016	~	Pump start delay time: range 0 – 254 sec
017	~	Pump stop delay time: range 0 – 254 sec

nXt-Protect controllers are a cost effective, reliable means to provide better control and protection without the need for costly bespoke switchboards

The following quick guides provide information regarding common applications.

The pumps illustrated in the following quick guides are mostly submersible type but the nXt-Protect controller is not limited to this type of pump.



With an understanding of how the controller responds to various inputs in each of the modes the controller can be used for applications beyond what is suggested.

For example, the controller can be connected in series with a VFD controlled pump to provide additional control inputs or to utilise the nXt-Protect controller delay times.

For even greater flexibility in your installation the nXt-Protect controller can be used as a 'module' in a more complex control environment.

Source control - Single float

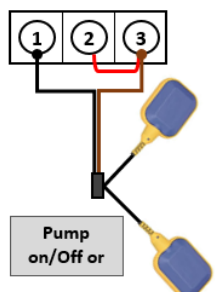

Source control - dual float

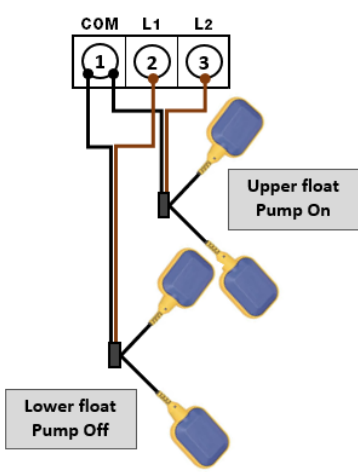

Floats

3 wire' floats allow for NO or NC wiring.

Connecting to the controller using the black and brown wires the circuit is closed when the float is up, open circuit when the float is down.

For greater differential, dual floats can be attached on the source inputs 1, 2 and 3.

When using a single float on the source input terminals #2 and #3 need to be bridged

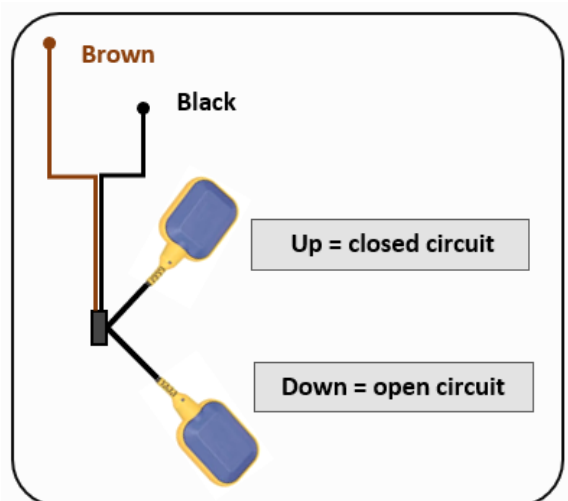

11. Quick guide: Transfer – source/destination control



Set the dip switches on the main PCB and cycle the power



Default mode - As Supplied

Pump On/Off operation is requested by a normally closed float or probes at the destination or a pressure switch in the delivery line.

A normally closed float switch at the source controls whether the pump will run or not depending on the liquid level.

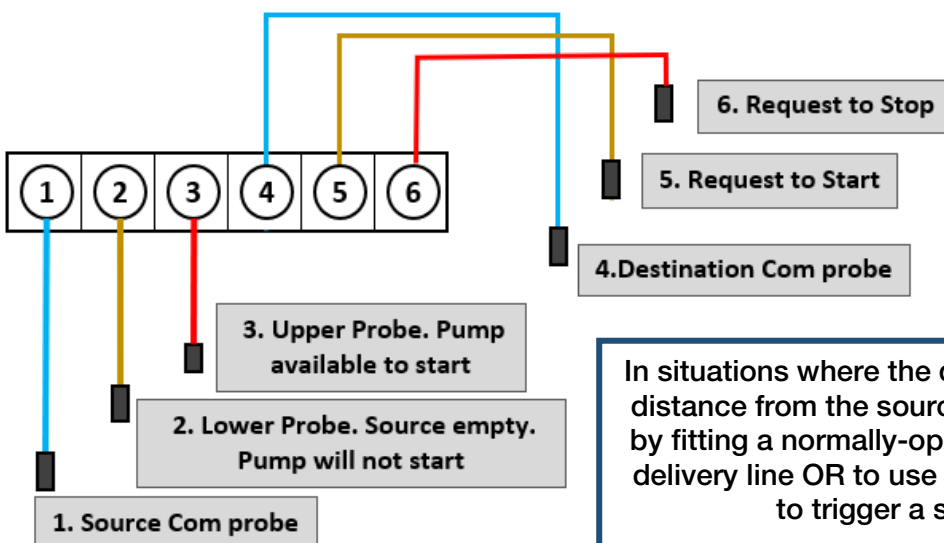
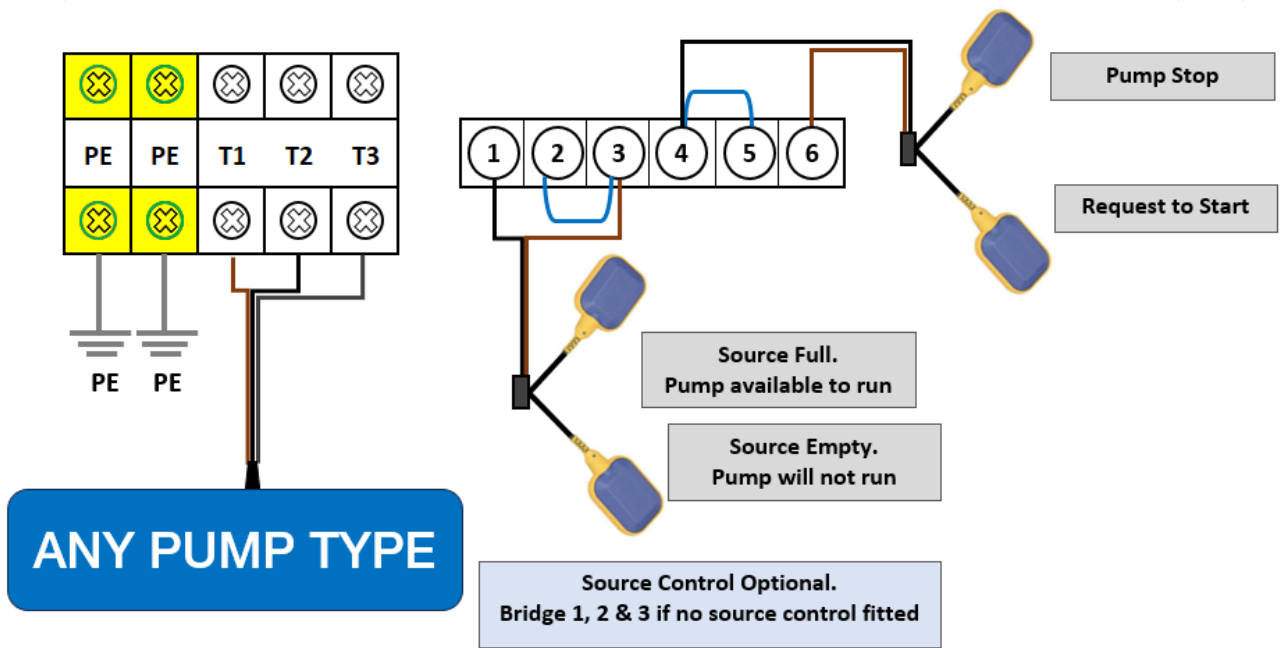

In situations where the destination is a significant distance from the source it is possible to control by fitting a normally-open pressure switch to the delivery line OR to use a remote wireless sensor to trigger a switched input.

Connect across 4 and 6 with a bridge across 4 and 5

12. Quick guide: Drainage Mode, float connected to pump



Set the dip switches on the main PCB and cycle the power

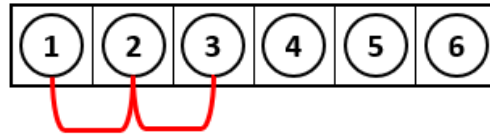

The pump On/Off operation is controlled by the float fitted to the pump.

The Controller provides additional protections **excluding** dry run.

A float connected to the controller can provide high level alarm function

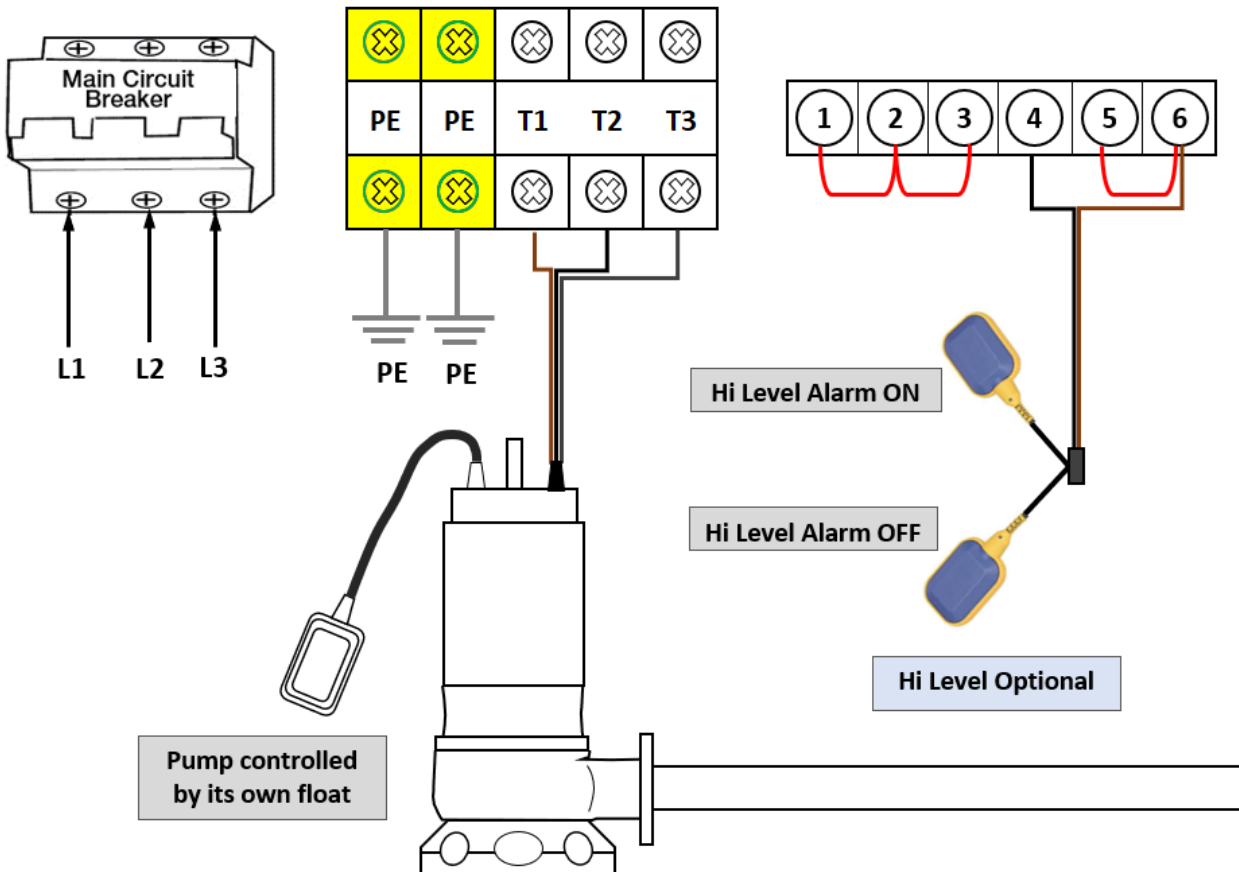

Parameter 001 must remain set to 0.0A to prevent underload alarming when the pump float interrupts pumping operation

13. Quick guide: Drainage Mode, external control inputs



Set the dip switches on the main PCB and cycle the power

A pump with its own float can be used in this configuration so long as the operational level of **Pump Stop Switch #1** is HIGHER than the float attached the pump.

Switched input - bridge terminals 5/6 and 2/3.

Pump switches on when the Pump Start switch 1/3 is in the On (Up) position

Pump runs until the Pump Stop switch 1/3 is in the Off (Down) position

High-Level alarm triggers when the High Level alarm switch 4/6 is in the On (Up) position.

The alarm will turn off when the Hi Level alarm switch 4/6 in in its Off (Down) position.

The pump will continue to run until the Pump Stop switch 1/3 is in the Off (down) position

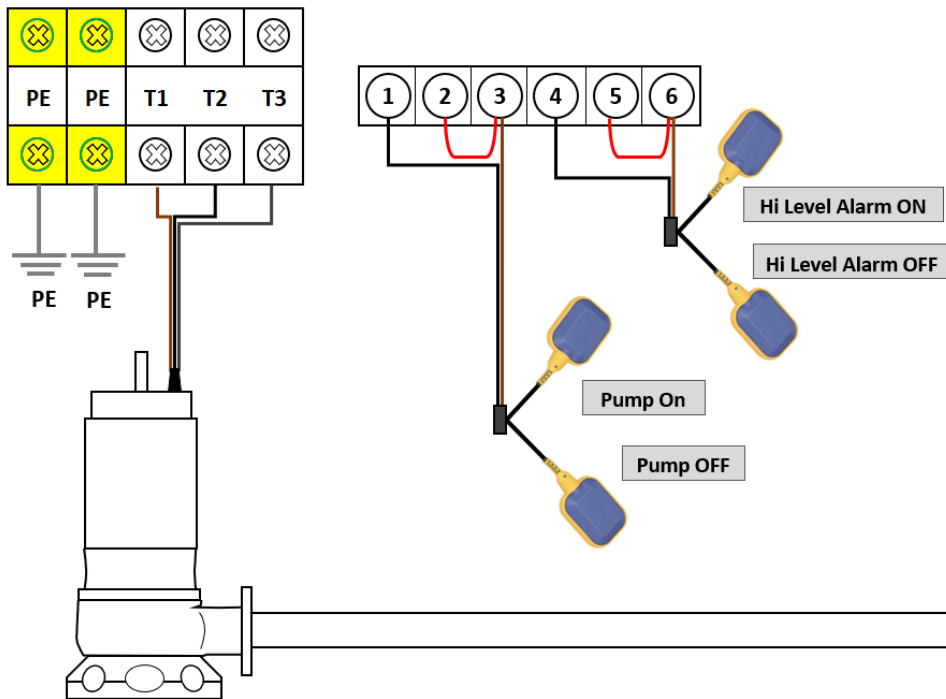

See page 13 for wiring twin control floats to achieve greater switching differential

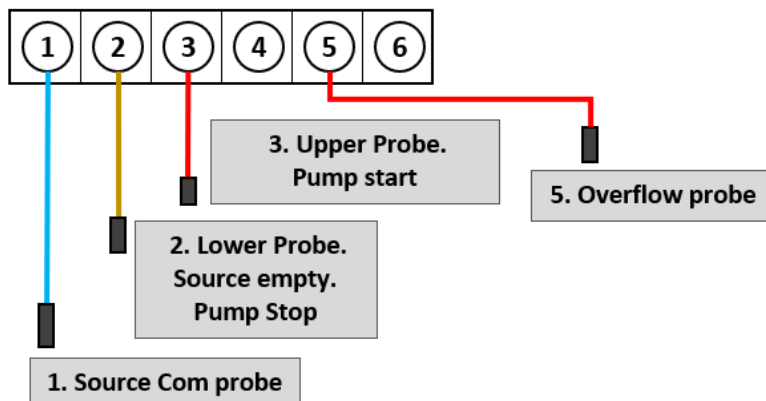

14. Quick guide: Pressure Boosting



Set the dip switches on the main PCB and cycle the power

Pump On/Off operation is controlled via a pressure switch on the delivery line.

Additional (optional) run/no run protection can be fitted at the source

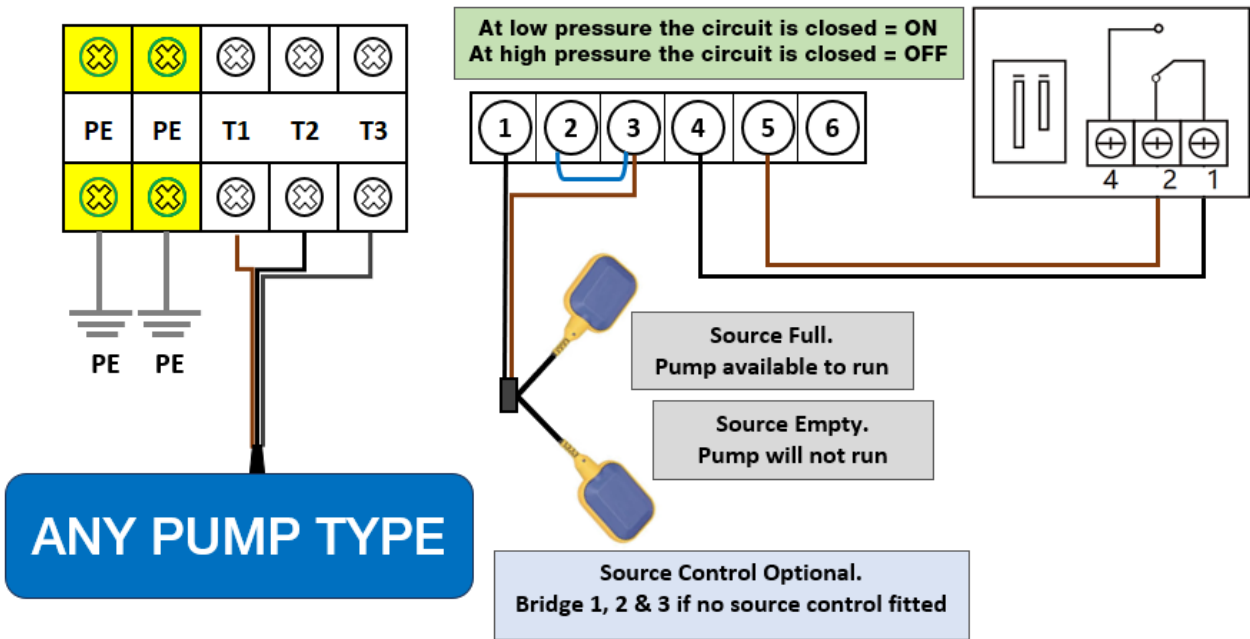

Or employ probes at the source

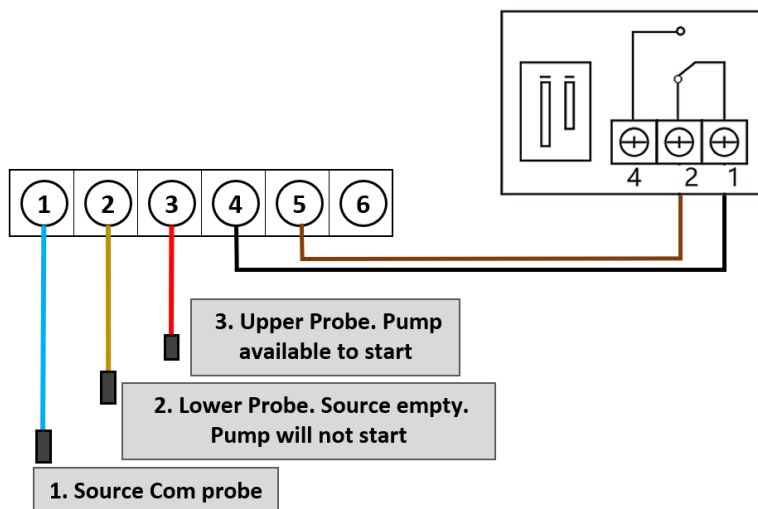

15. Quick guide: Sensorless Time control



Set the dip switches on the main PCB and cycle the power

In Auto mode, any a 'normal' START REQUEST activates the timer(s) 009 / 010 until that start request is terminated.

The next start request resets the timer count

008	00	Timer control (auto mode) – Parameters 009 – 101 00 = inactive 01 = active
009	5 min	Pump run timer: range 0 – 254 min In Auto mode the pump will run for the time set then stop and consider parameter 010 value An input requesting the pump to start after stopping takes priority and resets the timer count
010	5 min	Pump Stop timer: range 0 – 254 min In Auto mode having turned off at parameter 009 value the pump will remain off for the parameter 010 value then restart running for parameter 009 value etc

Application example: A low yielding bore controlled by a pressure switch.

- The pump starts on the pressure switch input but through experience, the customer knows it can only run for 10 mins before it will run dry and then will need 20mins for the water to recover.
- Set 009 to 10 minutes, and 010 to 20minutes.
- Activated by the pressure switch the pump will run for 10mins, turn off for 20mins then run again for 10mins etc.
- If the destination tank fills closing the ballcock the pressure switch will turn the pump off irrespective of the 009 run time.
- The process will start again on next run cycle

In Manual operation mode, the pump can be set running and it will switch off after the time value at **parameter 011** has passed.

011	0 min	Pump stop timer (manual mode): range 0 – 254 min In Manual operation mode the pump can be set running and it will stop after the time set in parameter.
-----	-------	---

16. Fault Messages

Fault Message	Possible Cause	Potential Solutions
UNDER V	The actual running voltage is lower than the calibrated voltage parameter 004 . The pump is in an under-voltage protection state	The controller will attempt to restart the pump every 5 minutes until line voltage is restored to normal If this fault occurs repeatedly, report low line voltage to the power supply company
OVER V	The actual running voltage is higher than the calibrated voltage parameter 005 . The pump is in over-voltage protection state	The controller will attempt to restart the pump every 5 minutes until line voltage is restored to normal If this fault occurs repeatedly, report high line voltage to the power supply company
PUMP STALLED	The pump motor running amperage has exceeded the normal (calibrated) running amperage by more than parameter 003 This could be due to physical jamming or a mechanical issue. If the pump stalled error occurs repeatedly at commissioning check the controller rating is matched to the pump	Pump Stalled is a 'critical error' and will not automatically reset. Isolate the power supply and inspect the pump for anything which has caused the sudden increase in load
OVER LOAD	Pump motor running amperage exceeds the normal (calibrated) running amperage by more than parameter 002	Isolate the power supply and inspect the pump for anything which is causing the pump to draw more amperage than the initial calibration value
UNDER LOAD	Pump motor running amperage is less than the normal (calibrated) running amperage by more than parameter 001	Under-load is sometimes referred to as Dry-run protection as a pump motor will draw less current when there is no load.
OPEN PHASE	The power supply has lost a phase.	Check fuses and wiring.
PHASE IMBALANCE	The incoming current between the three phases (R/S/T) differs by more than $\pm 15\%$	The controller will attempt to restart the pump every 4 minutes until the current between three phases is restored to normal
POWER PHASE REVERSAL	Sequence of the incoming wiring (R/S/T) is incorrect	Change the sequence of the wiring
PUMP NO CALIBRATION	Calibration not complete	Check the calibration Pump draw must exceed 1 amp

17. Warranties – Terms and Conditions

This warranty is given in addition to the consumer guarantees found within the Australian Competition and Consumer Act 2010 (Cth) for goods purchased in Australia and the Consumer Guarantees Act 1993 NZ for goods purchased in New Zealand:



1) White International Pty Ltd / White International NZ Ltd (White International) warrant that all products distributed are free from defects in workmanship and materials, for their provided warranty period as indicated on the top or opposite side of this document. Subject to the conditions of the warranty, White International will repair any defective products free of charge at the premises of our authorised service agents throughout Australia and New Zealand if a defect in the product appears during the warranty period. If you believe that you have purchased a defective product and wish to make a claim under this warranty, contact us on our Sales Hotline on 1300 783 601, or send your claim to our postal address or fax line below and we will advise you as to how next to proceed. You will be required to supply a copy of your proof of purchase to make a claim under this warranty.

2) This warranty excludes transportation costs to and from White International or its appointed service agents and excludes defects due to non-compliance with installation instructions, neglect or misuse, inadequate protection against the elements, low voltage or use or operation for purposes other than those for which they were designed. For further information regarding the suitability of your intended application contact us on our Sales Hotline on 1300 783 601. If you make an invalid claim under this warranty, the original product will be sent back to you unrepai red.

3) This warranty refers only to products sold after the 1st January 2012, and is not transferable to another product type and only applies to the original owner, purchaser or end user, and is in addition to the consumer guarantees found within the Competition and Consumer Act 2010 (Cth) for goods purchased in Australia and the Consumer Guarantees Act 1993 (NZ) for goods purchased in New Zealand.

4) Our goods come with guarantees that cannot be excluded under the Australian Consumer Law. You are entitled to a replacement or refund for a major failure and for compensation for any other reasonably foreseeable loss or damage. You are also entitled to have the goods repaired or replaced if the goods fail to be of acceptable quality and the failure does not amount to a major failure. 2 YEAR WARRANTY

5) To the fullest extent permitted by law, White International excludes its liability for all other conditions or warranties which would or might otherwise be implied at law. To the fullest extent permitted by law, White International's liability under this warranty and any other conditions, guarantees or warranties at law that cannot be excluded, including those in the Competition and Consumer Act 2010 (Cth), is expressly limited to: (a) in the case of products, the replacement of the product or the supply of equivalent product, the payment of the cost of replacing the product or of acquiring an equivalent product or the repair of the product or payment of the cost of having the product repaired, is at the discretion of White International or a 3rd party tribunal elected under the Competition and Consumer Act 2010 (Cth) for goods purchased in Australia and the Consumer Guarantees Act 1993 (NZ) for goods purchased in New Zealand; and

6) To the fullest extent permitted by law, this warranty supersedes all other warranties attached to the product or its packaging.

7) In the case of services, supplying the services again or the payment of the cost of having the services supplied again, is at the discretion of White International or a 3rd party tribunal elected under the Competition and Consumer Act 2010 (Cth) for goods purchased in Australia and the Consumer Guarantees Act 1993 (NZ) for goods purchased in New Zealand. 8) Our warranty commences from the date of purchase of the above-mentioned pumps. Proof of purchase is required before consideration under warranty is given.

Record your date of purchase in the space below and retain this copy for your records.

Date of Purchase**Model Purchased**



www.whiteint.com.au

1300 783 601

www.whiteint.co.nz

0800 509 506

Please always refer to our website for further technical information & new product innovations

Disclaimer: Every effort has been made to publish the correct information in this manual. No responsibility will be taken for errors, omissions or changes in product specifications.

© 2023 Copyright White International Pty Ltd

TM ® - **WARNING:** Please be aware that various brands & products depicted within this document are subject to trademark, patent or design registrations. Infringement of any intellectual property contained within this document without express written authority by the appropriate intellectual property holder may result in further legal action to be taken. For any queries regarding use of the contained information please feel free to contact White International Pty Ltd.