



Stainless Steel Pumps

Model BEST 2~5 Submersible Sump Pumps



Stainless steel submersible pump with open impeller and double mechanical seal in oil bath. Suitable for many sump applications.

Specifications

- Submersible pump with open impeller
- Maximum liquid temperature: 35 °C
- Maximum submergence: 10 m

Materials

- Pump casing: 304 Stainless Steel
- Impeller: 304 Stainless Steel
- Casing cover: 304 Stainless Steel
- Shaft: 303 Stainless Steel
- Seal Cover: 304 Stainless Steel
- Mechanical seal: Double mechanical seal in oil lubricated chamber, Silicon Carbide lower faces, Carbon/Ceramic upper faces.

Motor Data

- Air filled, dry submersible, 2 pole, 50 Hz
- Insulation class F
- IP68 protection
- 3 Phase - 400 Volt, 1 Phase - 230 Volt
- In built overload protection for 1 Phase

Range

- 40 mm Ø discharge
- 0.55 to 1.5 kW
- Single phase (up to 1.1 kW), automatic or manual versions
- Three phase, manual version only

Supply

- 10 m of cable (without plug)

Performance Curve

Synchronous Speed: 3000 rpm

Water temp: 20 °C

Applicable standard of test : ISO 9906 Annex A

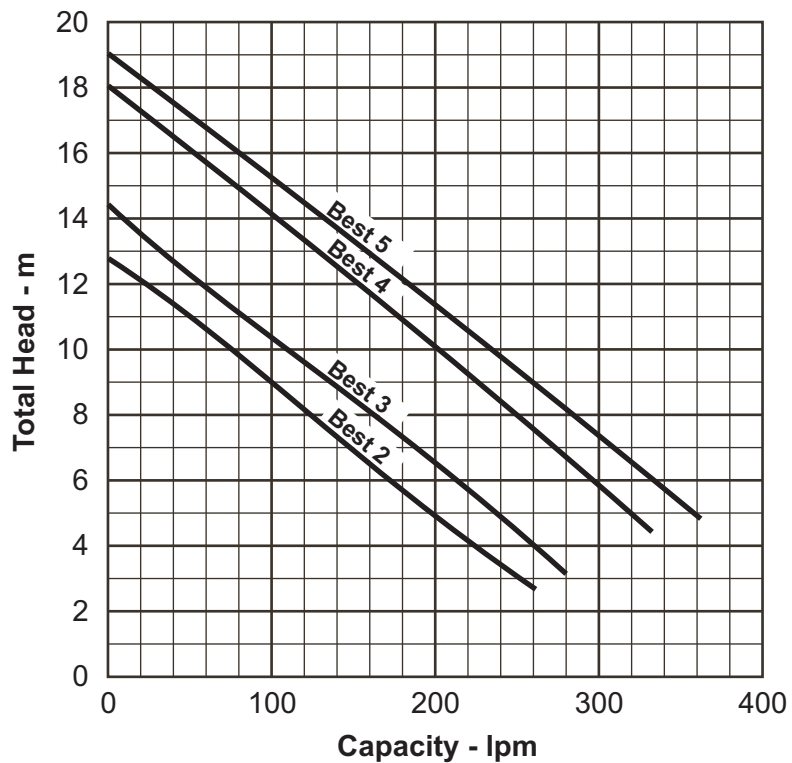

Model Code

Best 3 M
 Best 2 MA
 Best 5

1 Phase, Manual (M - Monophase)
 1 Phase, Automatic (A - Automatic)
 (blank) 3 Phase, Manual

"Size"
 2 = 0.55 kW
 3 = 0.75 kW
 4 = 1.1 kW
 5 = 1.5 kW

Performance Table

Pump Model	Motor Output	Discharge Ø mm	Full Load Current		Capacitor (1 Phase models only)	Capacity - lpm											
			1 Phase 230 V	3 Phase 400 V		Total Head - m											
Best 2	0.55 kW	40 mm	4.4 A	2.0 A	16 µF	11.4	9.8	8.3	6.7	5.0	2.9						
Best 3	0.75 kW	40 mm	5.6 A	2.4 A	20 µF	12.7	11.1	9.5	7.9	6.4	4.0	3.2					
Best 4	1.1 kW	40 mm	7.3 A	3.0 A	31.5 µF	16.6	15.0	13.4	11.7	10.0	7.5	6.7	4.6				
Best 5	1.5 kW	40 mm	—	3.3 A	—	17.7	16.1	14.5	12.8	11.4	9.0	8.0	6.0	5.0			

Sectional Drawing

Model BEST 2~5

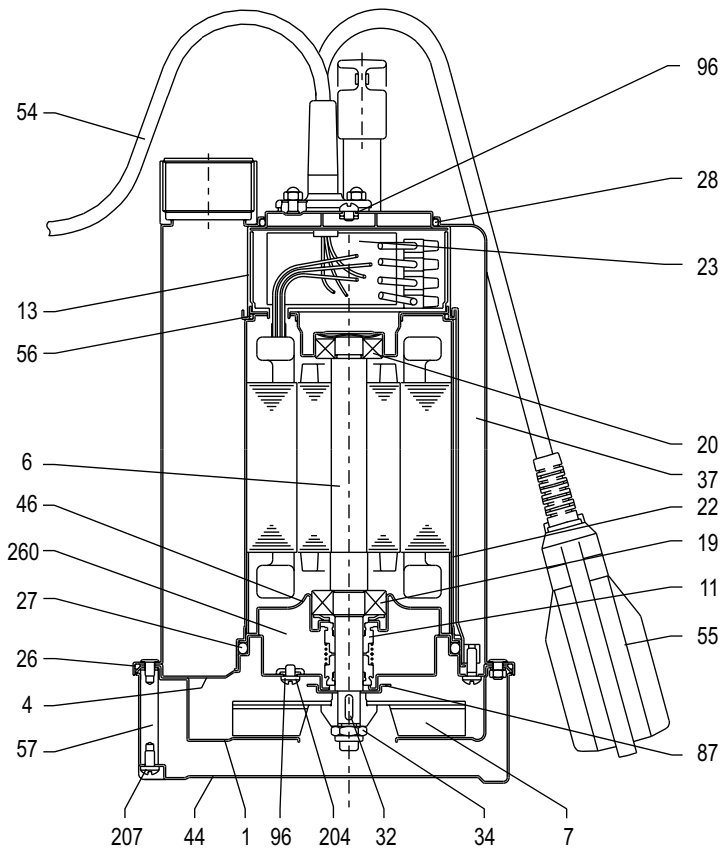

No.	Description	Material	Qty.
1	Casing	304 Stainless Steel	1
4	Motor bracket	304 Stainless Steel	1
6	Shaft with rotor [#]	303 Stainless Steel	1
7	Impeller	304 Stainless Steel	1
11	Mechanical seal	SiC:SiC/Carb:Cer/NBR	1
13	Motor cover	304 Stainless Steel	1
19	Lower bearing	Sealed Ball Bearing	1
20	Upper bearing	Sealed Ball Bearing	1
22	Tie rod	304 Stainless Steel	3
23	Capacitor [1]	-	1
26	O-Ring	NBR Rubber	1
27	O-Ring	NBR Rubber	1
28	O-Ring	NBR Rubber	1
32	Impeller key	304 Stainless Steel	1
34	Impeller nut	303 Stainless Steel	1
37	Pump casing	304 Stainless Steel	1
44	Strainer	304 Stainless Steel	1
46	Lower bearing bracket	304 Stainless Steel	1
54	Submersible power cable	H07RN-F	1
55	Float switch [2]	-	1
56	O-Ring	NBR Rubber	1
57	Bolt	303 Stainless Steel	3
87	Impeller ring	304 Stainless Steel	1
96	O-Ring	NBR Rubber	3
204	Screw	304 Stainless Steel	3
207	Screw	304 Stainless Steel	3
260	Oil	Esso MARCOL 152	180 ml

- refers to pump side of shaft material
 1 - only for single phase versions
 2 - only for automatic single phase versions

Dimensions

Model BEST 2~5

Units: mm unless otherwise specified

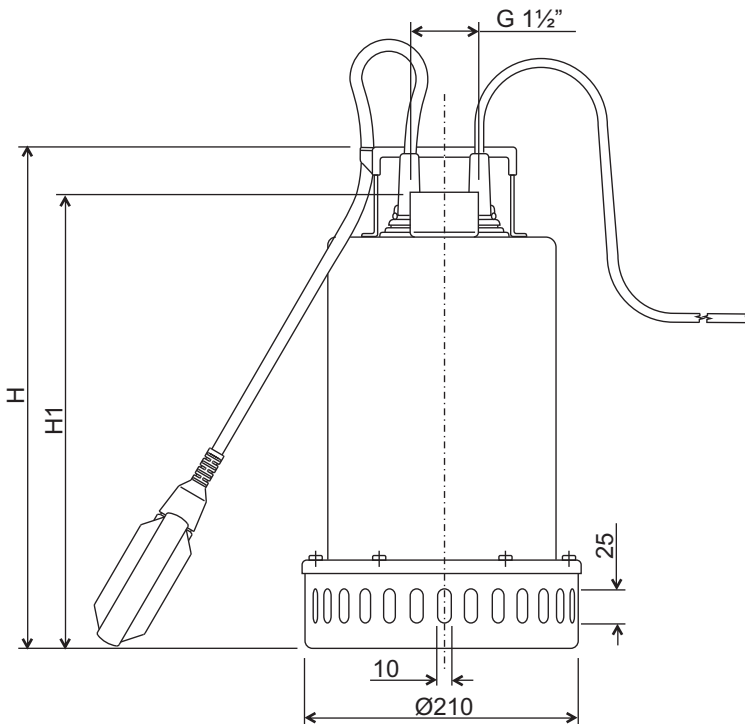

Pump Model	Dimensions		Approx. Weight kg
	H	H1	
Best 2	352	315	12
Best 3	352	315	13
Best 4	377	340	14
Best 5	377	340	14

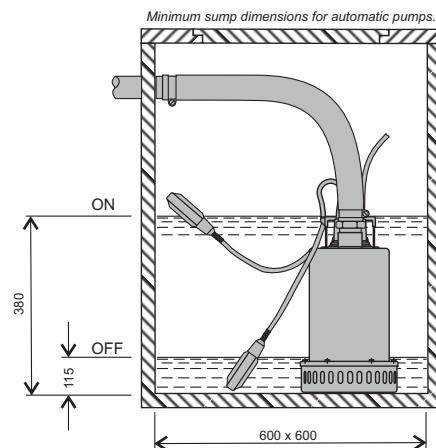

Specifications subject to change without notice