



BAKER HYDRO

ORION PUMPS

Orion pumps incorporate the very latest technology - in both design and construction to produce a high performance, reliable pump.

Efficient Design

The Orion's hydraulic design maximizes the output of the pump while minimizing turbulence. The pump's efficient performance shortens run times and reduces energy consumption.

Engineered Durability

Orion's pump body is manufactured utilising state of the art engineering plastic moulding with a single piece strainer pot and volute for extra strength.



ORION

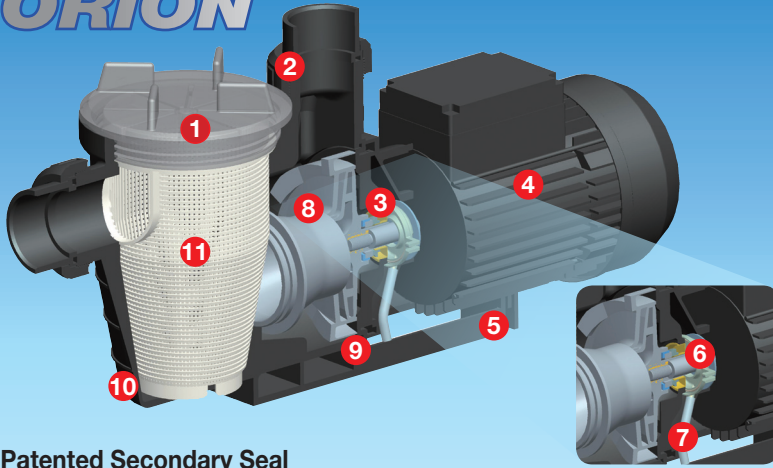

1. Clear basket lid - easy visual inspection.
2. 40mm quick connect barrel unions for UPVC pipe.
3. High grade carbon/graphite mechanical seal with 316 stainless steel spring assembly.
4. High performance motor:
 - High grade stainless steel motor shaft.
 - Fan cooled.
 - Thermal overload protection
5. Stable support base.
6. Secondary seal - for extra protection.
7. Secondary seal drain pipe.
8. Hydraulically efficient impeller and diffuser design.
9. Drain plugs.
10. Strong single piece glass filled thermoplastic pump body.
11. 1.5 litre strainer basket - capture debris and protects the pump's impeller.

Patented Secondary Seal

Situated between the pump's wet end and motor, a mechanical seal forms a seal around the motor shaft to prevent water from running out along the motor's shaft. The mechanical seal is the wearing part of any pool pump.

A mechanical seal may leak water if the pump is ever run dry or simply worn out. If a leaking mechanical seal is not replaced promptly, water will travel along the motor's shaft and ruin the motor in a very short period of time.

Orion's Secondary Seal protects the pump motor's end shield from any water contact, by capturing any leaks and draining it out of the pump.

Specifications

Model	Flow Rate (lpm)		Nom. HP	kW	Amps	Total Length (mm)	Motor Frame (mm)
	8m	10m					
Orion 75	110	50	0.75	0.61	2.80	536	63
Orion 100	215	170	1.00	0.82	3.60	559	71
Orion 125	245	185	1.25	0.88	3.90	559	71
Orion 150	295	245	1.50	1.09	4.90	580	83

Phase	Volts	Cycle	RPM
1	220-240	50	2860

Flow Curves

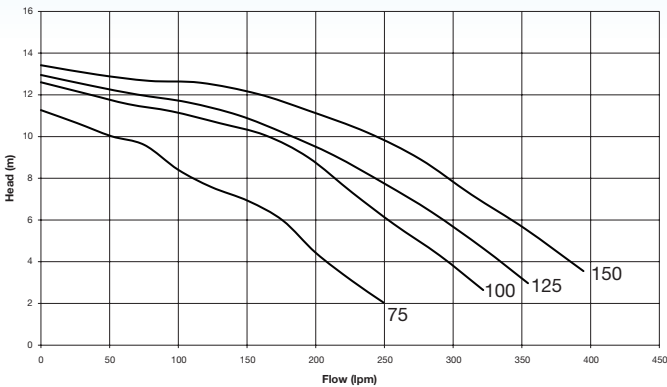

Noise Levels

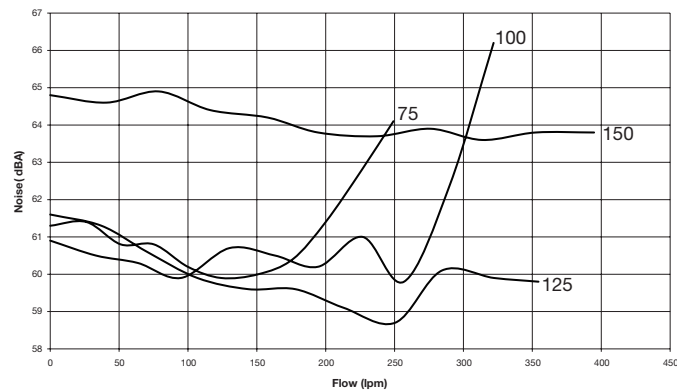

Note: Baker Hydro Pumps are tested to Australian Standards AS/NZS3136.

Dimension

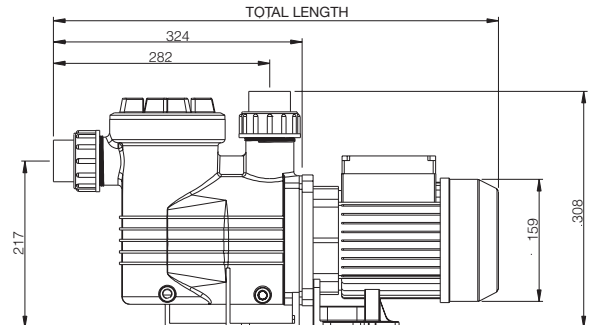

Warranty

Pumps	3 years (conditional)*
Wet End	3 years
Motor, mechanical seal, hair & lint pot lid, o'ring, basket, impeller & diffuser	2 years
Commercial applications	1 year
Labour	1 year