

DT25EXD 1" (25NB)

Pump Specifications

Model No.	DT25EXD
Port Size:	1" (25NB) BSPP Female
Max. Flow:	23 L/min
Max. Suction Lift:	6m
Max. Discharge Head:	6m
Max. Solid Size:	15mm
Weight:	46 KG

Motor Specifications

Brand:	Weg W22 Three Phase
kW:	.37
RPM:	1380
Voltage:	415
FLC:	.96 amps
IP Rating:	66
EX Rating:	EX d IIC T4 Ta -55 to +80°C Gb
Certification:	IECEx BAS 13.0008X



Materials of Construction

Diaphragm:	Nitrile
Valves:	Nitrile
Castings:	SG Iron E-Coated
Base Plate:	Mild Steel E-Coated

Options:	EPDM & Viton
Options:	EPDM, Viton & Polyurethane
Options:	Bronze & Stainless Steels
Options:	Stainless Steel, Carry & Trolley Frame

Recommended Accessories

Discharge Pulsation Dampener	Part No. PD1D
Suction Pulsation Dampener	Part No. PD1S
Fluid End Service Kit	Part No. D25K1

MINIMUM INTERNAL PIPE SIZE FOR LIQUIDS WITH SAME VISCOSITY AS WATER					
PUMP SIZE	SUCTION PIPE LENGTH M		DISCHARGE PIPE LENGTH M		
	D25	0 - 5	5 - 10	0 - 5	5 - 10
	25	32	32	40	40
	SUCTION PIPE ID IN MM		DISCHARGE PIPE ID IN MM		
USE OF PIPES SMALLER THAN STATED WILL VOID WARRANTY					

Please refer to D Series Installation & Maintenance manual before installing or servicing the diaphragm pump.

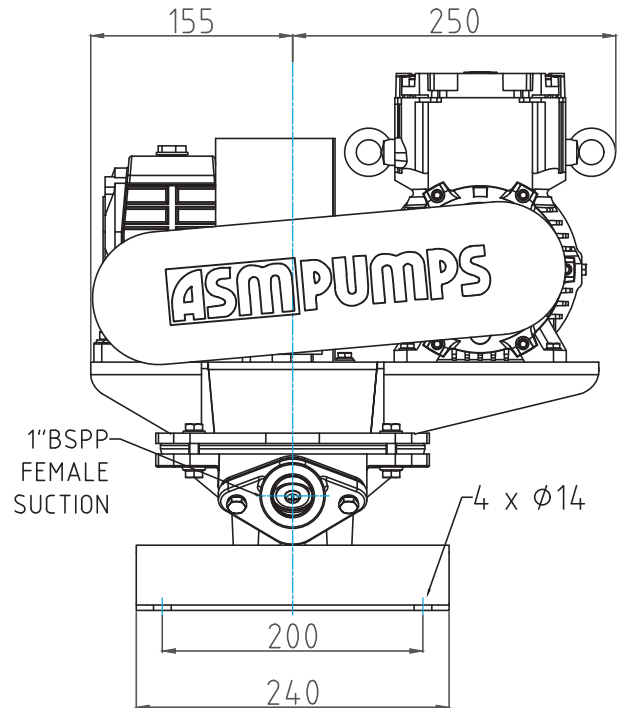
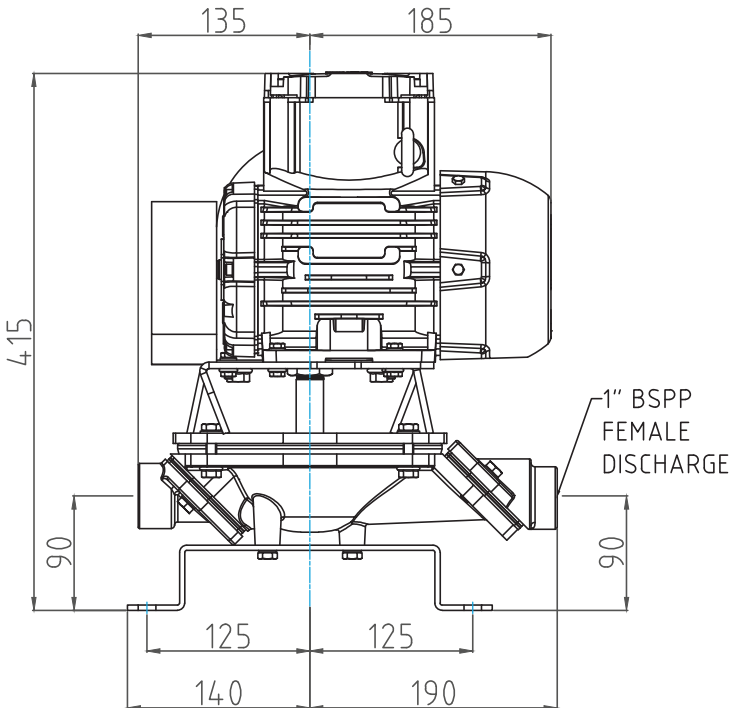

ASM PUMPS
 14 Nicole Way, Dandenong South, Victoria, 3175
 Ph: 03 9793 7577 Email: sales@asmpumps.com.au
www.asmpumps.com.au

