



SPECIFICATIONS

Power	5.5KW / 7.5HP
Frequency	50Hz
Discharge	80mm / 3 inch female BSP
Weight (Excl cable)	74Kg
Solid Passage	20 mm
Phase	3ø
Voltage	415
Full Load Amps	11.2
Maximum Liquid Temperature	0-40° C
Maximum Submersion Depth	30m (100 feet)
Motor type	Dry motor
Motor Speed	2 Pole (2800 rpm)
Motor Insulation	Class F
Motor Protection	IP68
Protector	Auto cut
Motor Bearings	Ball Type
	Dual Mechanical seal
Seal Method	Upper: Carbon/Ceramic Lower: Silicon/Silicon
Impeller Type	Semi-open
Motor Cover Construction	SCS14 Stainless Steel
Motor Casing Construction	316 Stainless Steel
Motor Shaft Construction	316 Stainless Steel
Pump Casing Construction	SCS14 Stainless Steel
Impeller Construction	SCS14 Stainless Steel
Strainer Construction	304 Stainless Steel
Cable Material	H07RN-F

MODEL NUMBER STRUCTURE

U	Ultraflow
M	'M' indicates Manual, without floatswitch 'A' indicates Automatic, without floatswitch
D	'D' indicates 'Drainage' series
N	'N' indicates series
SS	'SS' indicates Stainless Steel wetted parts
5500	Power consumption in 'Watts'
80	Outlet size
3	'3' indicates 415 volt three phase

PERFORMANCE CURVES

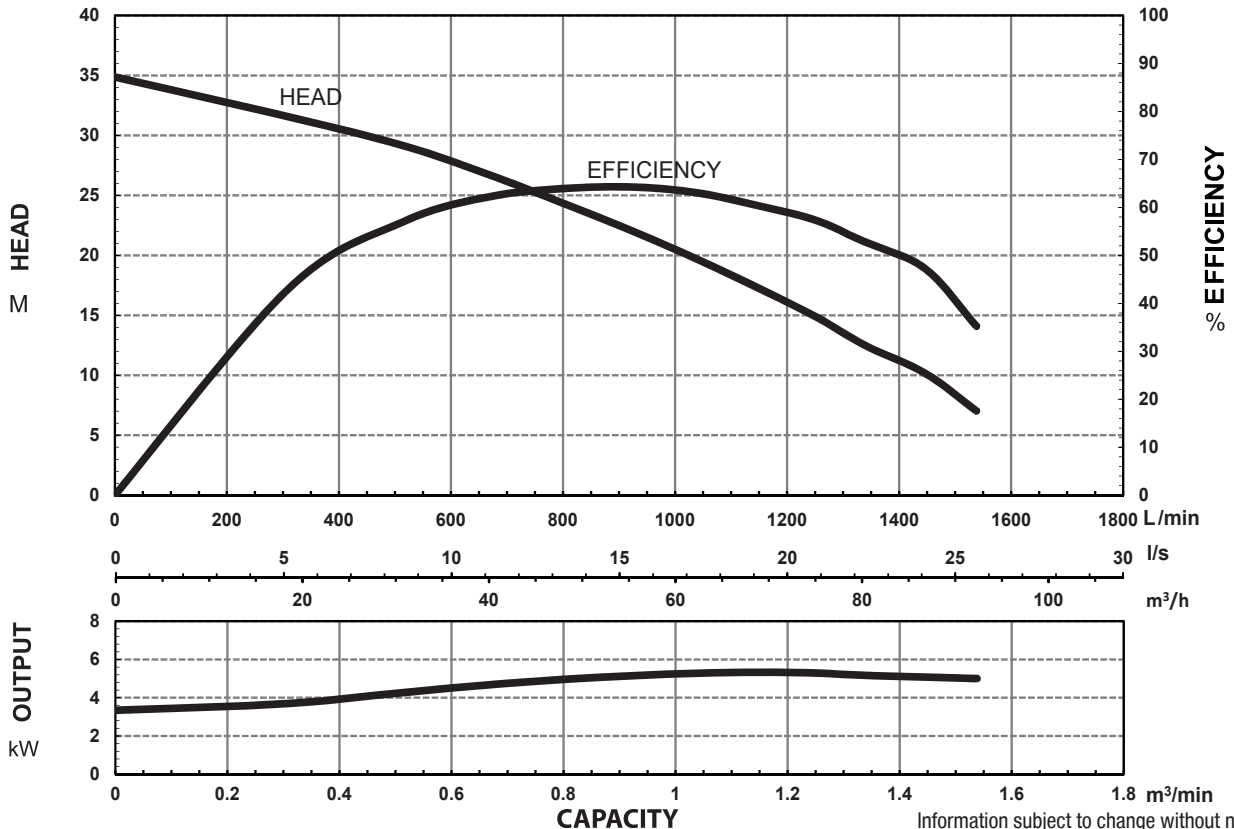

Information subject to change without notice.



SECTIONAL DRAWING & MATERIALS LIST

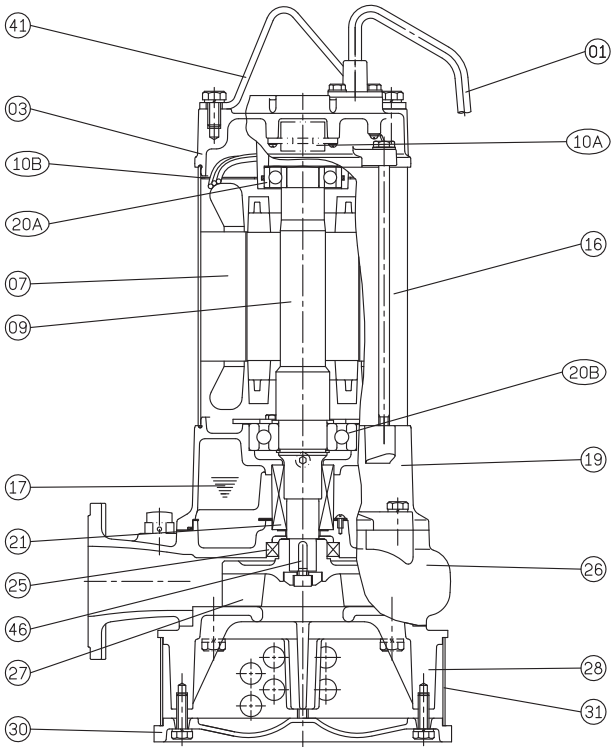

PART NUMBER	DESCRIPTION	MATERIAL
01	Cable	H07RN-F
03	Upper Motor Cap/ Bearing Housing	SCS14 Stainless Steel
07	Motor Stator	
09	Shaft With (With Rotor)	(Shaft) Stainless Steel 316
10 A	Auto Cut Out Overload	
10B	Auto Cut Out Overload Mounting Plate	
16	Motor Casing	316 Stainless Steel
17	Lubricant	Turbine Oil
19	Lower Bearing Housing	SCS14 Stainless Steel
20A & 20B	Upper Bearing & Lower Bearing	
21	Mechanical Seal	Upper: Carbon/Ceramic Lower: Silicon/Silicon
25	Oil Seal	Nitrile
26	Pump Casing	SCS14 Stainless Steel
27	Impeller	SCS14 Stainless Steel
28	Suction Cover	SCS14 Stainless Steel
30	Pump Base Plate	SCS14 Stainless Steel
31	Strainer	316 Stainless Steel
41	Handle	304 Stainless Steel
46	Impeller Key	304 Stainless Steel
47	O'rings	
55	Oil Plug	304 Stainless Steel

When ordering spare parts as above, simply add the pump model number to the part number from the list above. For example, a power lead (part '01'), the complete spare part name would be written as '01-UMDNSS5500/80/3'.

DIMENSIONAL DRAWING

ELBOW (FLANGE) SET

GUIDE RAIL SYSTEM DIMENSIONS USING GRSS80 HP GUIDE RAIL KIT

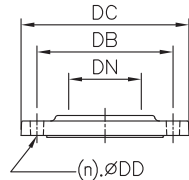
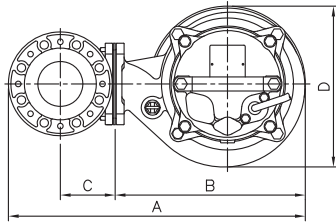

DIMENSIONS - mm

DN	DB	DC	DD
80	150	185	15

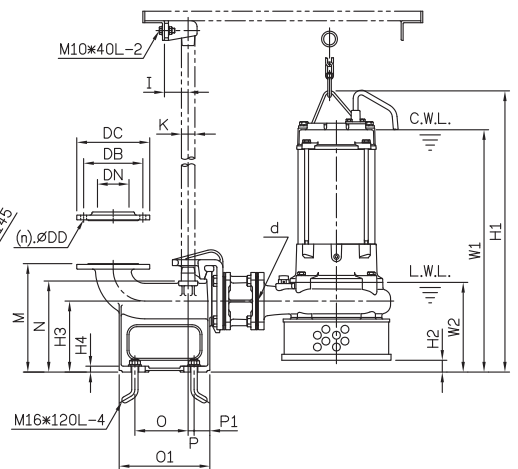
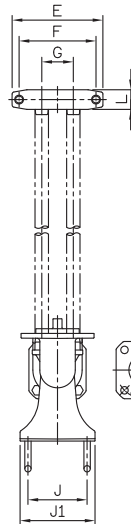
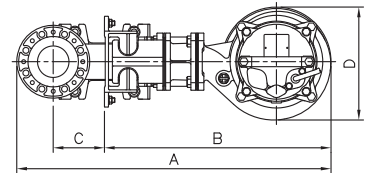

**DIMENSIONS - mm
UMDNSS5500/80/3**

d	A	B	C	D	E	F	G	H	I
80	528	338	98	286	271	198	585	684	151

DIMENSIONS - UMDNSS5500/80/3

d	A	B	C	D	E	F	G	I	J	J1	K	L	M	O	O1	P	P1	W1	W2	H1	H2	H3	H4
80	797	574	130	286	230	195	80	60	150	190	32	50	275	231	135	230	40	615	228	714	30	180	15

Information subject to change without notice.

