

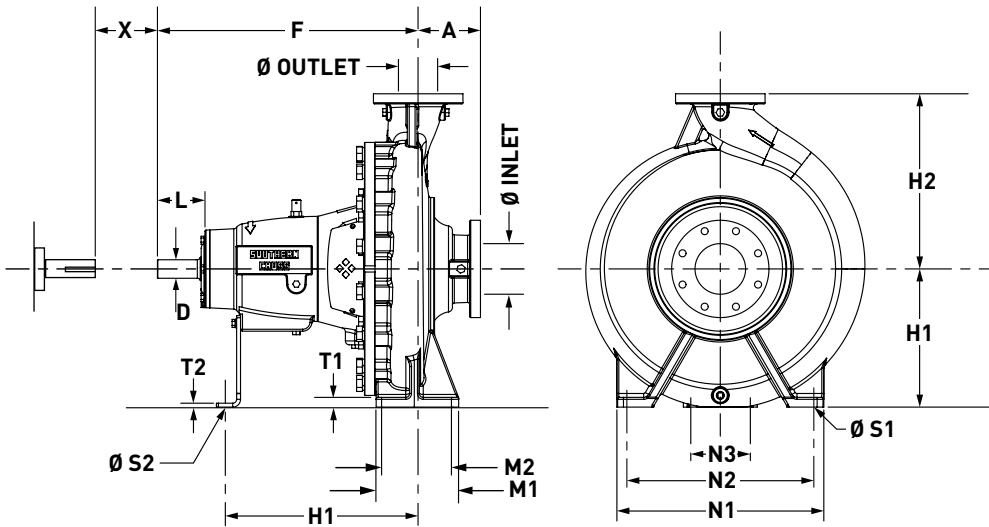

CENTRIFUGAL PUMP TECHNICAL DATA

ISO2858
END SUCTION PUMPS
TECHNICAL DATA

PUMP DIMENSIONS



Standard Flange Drilling to AS2129 -1982 Table "E".

Other drilling options available on request.

Dimensions in millimetres.

PUMP SIZE			SHAFT NO.	PUMP DIMENSIONS				MOUNTING DIMENSIONS									BOLT HOLES		SHAFT END		GAP *	WEIGHT (KG)
INLET	OUTLET	IMP DIA		A	F	H1	H2	B	M1	M2	N1	N2	N3	T1	T2	W	S1	S2	D	L		
50	32	160	1	80	385	132	160	50	100	70	240	190	110	12	6	285	M12	M12	24	50	100	43
50	32	200	1	80	385	160	180	50	100	70	240	190	110	13	6	285	M12	M12	24	50	100	49
65	50	160	1	80	385	132	160	50	100	70	240	190	110	12	6	285	M12	M12	24	50	100	44
65	40	200	1	100	385	160	180	50	100	70	265	212	110	13	6	285	M12	M12	24	50	100	51
65	40	250	2	100	500	180	225	65	125	95	320	250	110	14	6	370	M12	M12	32	80	100	71
65	40	315	2	125	500	200	250	65	125	95	345	280	110	16	6	370	M12	M12	32	80	100	90
80	65	160	1	100	385	160	180	50	100	70	265	212	110	13	6	285	M12	M12	24	50	100	49
80	50	200	1	100	385	160	200	50	100	70	265	212	110	13	6	285	M12	M12	24	50	100	53
80	50	250	2	125	500	180	225	65	125	95	320	250	110	15	6	370	M12	M12	32	80	100	76
80	50	315	2	125	500	225	280	65	125	95	345	280	110	18	6	370	M12	M12	32	80	100	94
100	80	160	2	100	500	160	200	65	125	95	280	212	110	14	6	370	M12	M12	32	80	100	68
100	65	200	2	100	500	180	225	65	125	95	320	250	110	15	6	370	M12	M12	32	80	140	72
100	65	250	2	125	500	200	250	80	160	120	360	280	110	16	6	370	M16	M12	32	80	140	84
100	65	315	3	125	530	225	280	80	160	120	400	315	110	18	8	370	M16	M12	42	110	140	122
125	80	200	2	125	500	180	250	65	125	95	345	280	110	16	6	370	M12	M12	32	80	140	81
125	80	250	2	125	500	225	280	80	160	120	400	315	110	18	6	370	M16	M12	32	80	140	88
125	80	315	3	125	530	250	315	80	160	120	400	315	110	20	8	370	M16	M12	42	110	140	130
125	80	400	3	125	530	280	355	80	160	120	435	355	110	20	8	370	M16	M12	42	110	140	163
125	100	200	2	125	500	200	280	80	160	120	360	280	110	17	6	370	M16	M12	32	80	140	87
125	100	250	3	140	530	225	280	80	160	120	400	315	110	18	8	370	M16	M12	42	110	140	122
125	100	315	3	140	530	250	315	80	160	120	400	315	110	19	8	370	M16	M12	42	110	140	138
125	100	400	3	140	530	280	355	100	200	150	500	400	110	20	8	370	M20	M12	42	110	140	175
125	100	500	4	160	670	355	450	100	210	150	540	450	140	25	10	500	M20	M16	48	110	180	378
150	125	250	3	140	530	250	355	80	160	120	400	315	110	19	8	370	M16	M12	42	110	140	135
150	125	315	3	140	530	280	355	100	200	150	500	400	110	20	8	370	M20	M12	42	110	140	156
150	125	400	3	140	530	315	400	100	200	150	500	400	110	21	8	370	M20	M12	42	110	140	193
150	125	500	4	160	670	355	450	100	210	150	540	450	140	25	10	500	M20	M16	48	110	180	402
200	150	315	4	160	670	315	400	100	210	150	540	450	140	20	10	500	M20	M16	48	110	180	274
200	150	400	4	160	670	315	450	100	210	150	540	450	140	25	10	500	M20	M16	48	110	180	339
200	150	500	4	160	670	400	500	100	210	150	540	450	140	25	10	500	M20	M16	48	110	180	426
250	200	315	4	180	670	315	450	100	210	150	540	450	140	25	10	500	M20	M16	48	110	180	314

* Gap necessary for the withdrawal or bearing housing, backplate and impeller assembly towards the drive end.