

Pumps and Pipes

52 Moss St, Slacks Creek
(07) 3208 9499

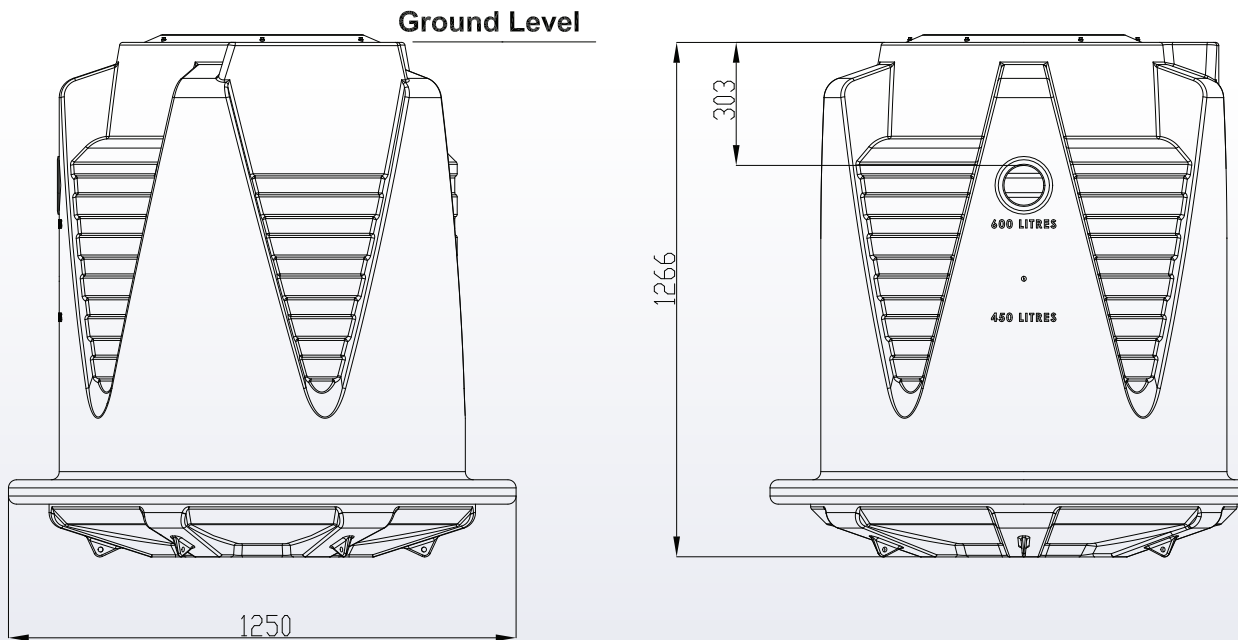

RELN 600L Pumpwell

- Pumpwell is a housing for black and greywater pumps
- Designed to pump wastewater in domestic systems where flow in the pipe is required to be pumped to a higher location
- 600L capacity (minimum requirement for NSW)
- Approved to requirements of Australian Standard AS/NZS1546.1

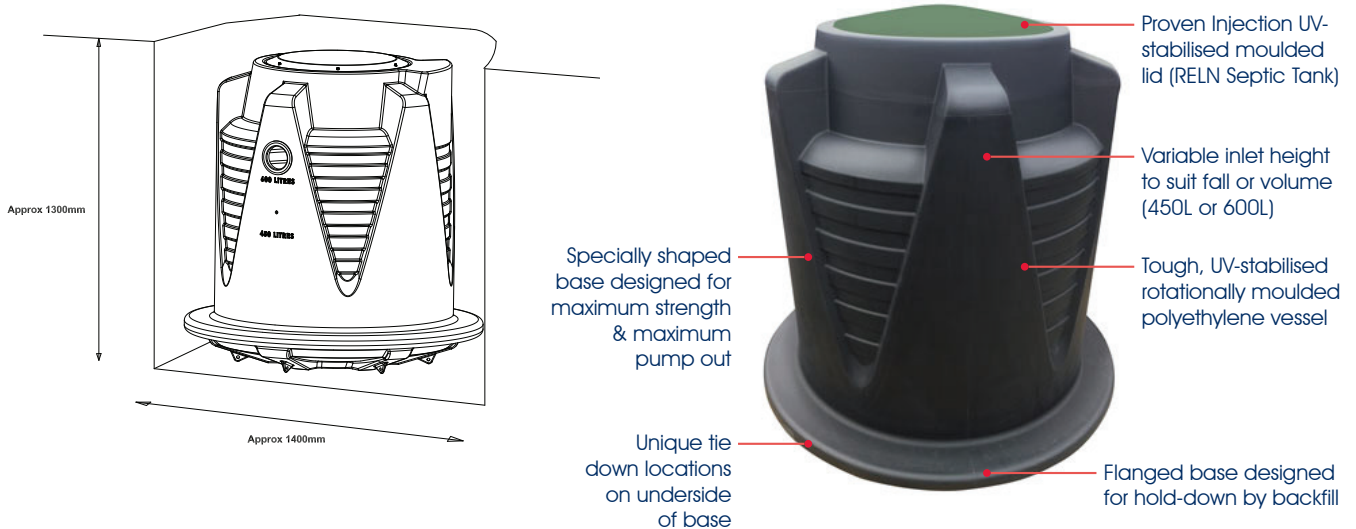



Pumps and Pipes

Pumpwell

RELN Pumpwell is a housing for Black and Grey water pumps, designed to pump wastewater in domestic systems where the flow in the pipe is required to be pumped to a higher location.

> Pumpwell (1266mm height x 1250mm diameter)

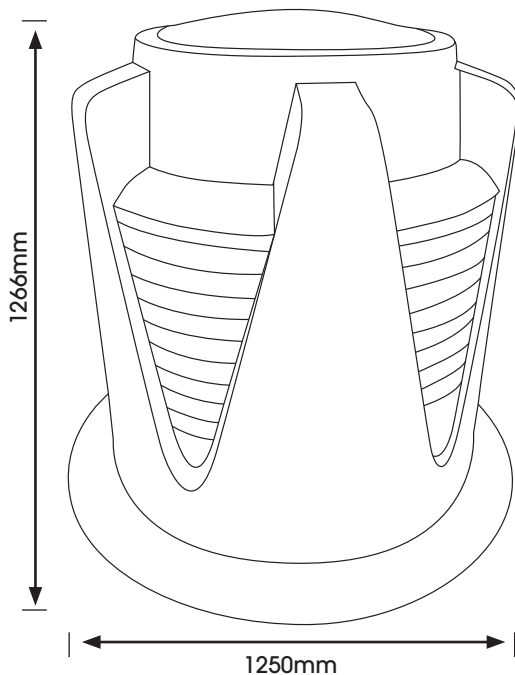

Pump Well

Pump Well - 600 Litre

Product Code: 000836

Weight: 45kg



- 600L Capacity (Minimum requirement for NSW)
- Approved to requirements of Australian Standard AS/NZS1546.1
- Tough UV stabilised rotationally moulded polyethylene vessel
- Proven Injection UV stabilised moulded lid (RELN Septic Tank)
- Size 1266 mm high x 1250mm diameter
- Easy 100mm PVC Sewer pipe connection via Pipe seal Gasket
- Variable inlet height to suit fall or volume required (between 450L and 600L). Simply drill to desired height in marked positions
- Flanged based designed for hold-down by backfill
- Unique tie down locations on underside of base suit attachment with reo bar set in concrete base for higher water table areas
- Specially shaped base designed for maximum strength and maximum pump out

Range: Base, Manhole Cover, Screws 10g Self Tapping, Uni-Seal gasket ring

Display: Brochure available.

> Frequently Asked Questions

Q1. What size hole do I need to dig to fit my Pumpwell?

A. Approximately 1400mm width by 1300mm height.

Q2. Do you bury the tank lid?

A. No. The manhole cover must be finished at normal ground level for ongoing Pumpwell inspection and maintenance.

Q3. Where can I place my Pumpwell?

A. Please contact your local council for placement advice. Pumpwell should never be placed near trafficable areas, building foundations, farms animals or livestock.



Pumps and Pipes

Pump Station

RELN Pump Station tanks are designed to take Black and Greywater tanks with flexibility to the next level.

- Heavy Duty Roto-molded 600L polyethylene
- Bianco B120GS2 grinder pump with automatic control
- Complete with 40mm discharge piping, valves and fittings including brass gate and swing check valve and barrel union for easy pump removal
- High level alarm with audible and visible alarm functions
- Australian made and assembled ready for installation
- Ideal for Domestic sewage and drainage applications

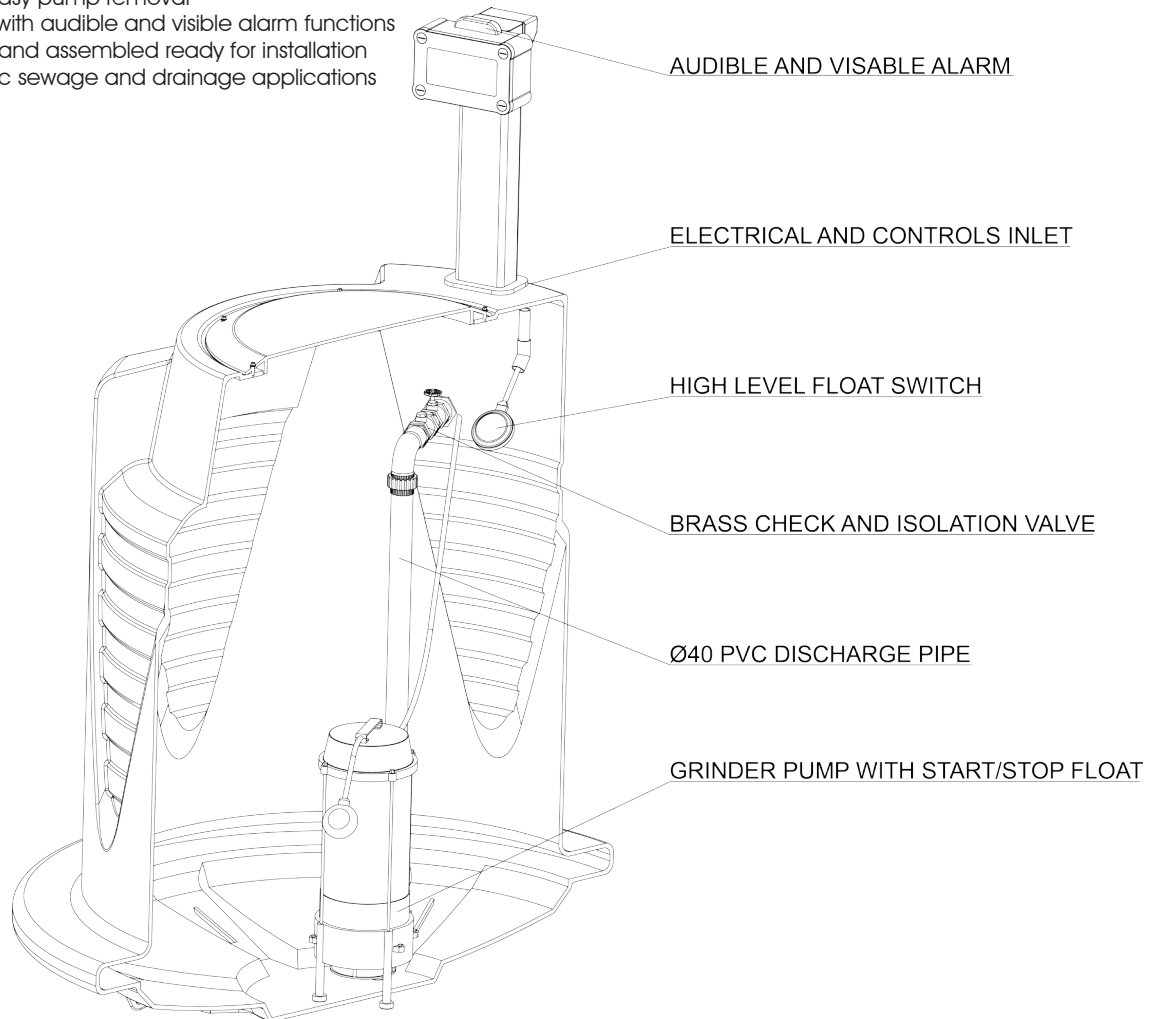

Pump Station Grey Water
- 600 Litre

Product Code: WESPPS-GW

Weight: 95kg



Pump Station Sewage
- 600 Litre

Product Code: WESPPS-S

Weight: 95kg