



Models: **UMDN1100/50/1**
UADN1100/50/1
UMDN1100/50/3
UADN1100/50/3



MODEL NUMBER STRUCTURE

U	Ultraflow
M	'M' indicates Manual, without floatswitch 'A' indicates Automatic, with floatswitch
D	'D' indicates 'Drainage' series
N	'N' indicates series
1100	Power consumption in 'Watts'
50	Outlet size
1	'1' indicates 240 volt single phase '3' indicates 415 volt three phase

SPECIFICATIONS

Power	1.1kW / 1.5HP	
Frequency	50Hz	
Discharge	50mm / 2 inch female BSP	
Weight (Excl cable)	20Kg – Single Phase Models 18Kg – Three Phase Models	
Solid Passage	7 mm	
Phase	1 ϕ	3 ϕ
Voltage	240	415
Full Load Amps	6.4	2.3
Maximum Liquid Temperature	0-40° C	
Maximum Submersion Depth	30m (100 feet)	
Motor type	Dry motor	
Motor Speed	2 Pole (2800 rpm)	
Motor Insulation	Class B	
Motor Protection	IP68	
Protector	Auto cut	
Motor Bearings	Ball Type	
Seal Method	Dual Mechanical seal Upper: Carbon/Ceramic Lower: Silicon/Silicon	
Impeller Type	Semi-open	
Motor Cover Construction	FC-200 Cast Iron	
Motor Casing Construction	304 Stainless Steel	
Motor Shaft Construction	410 Stainless Steel	
Pump Casing Construction	FC-200 Cast Iron	
Impeller Construction	FC-200 Cast Iron	
Strainer Construction	304 Stainless Steel	
Cable Material	H07RN-F	

PERFORMANCE CURVES

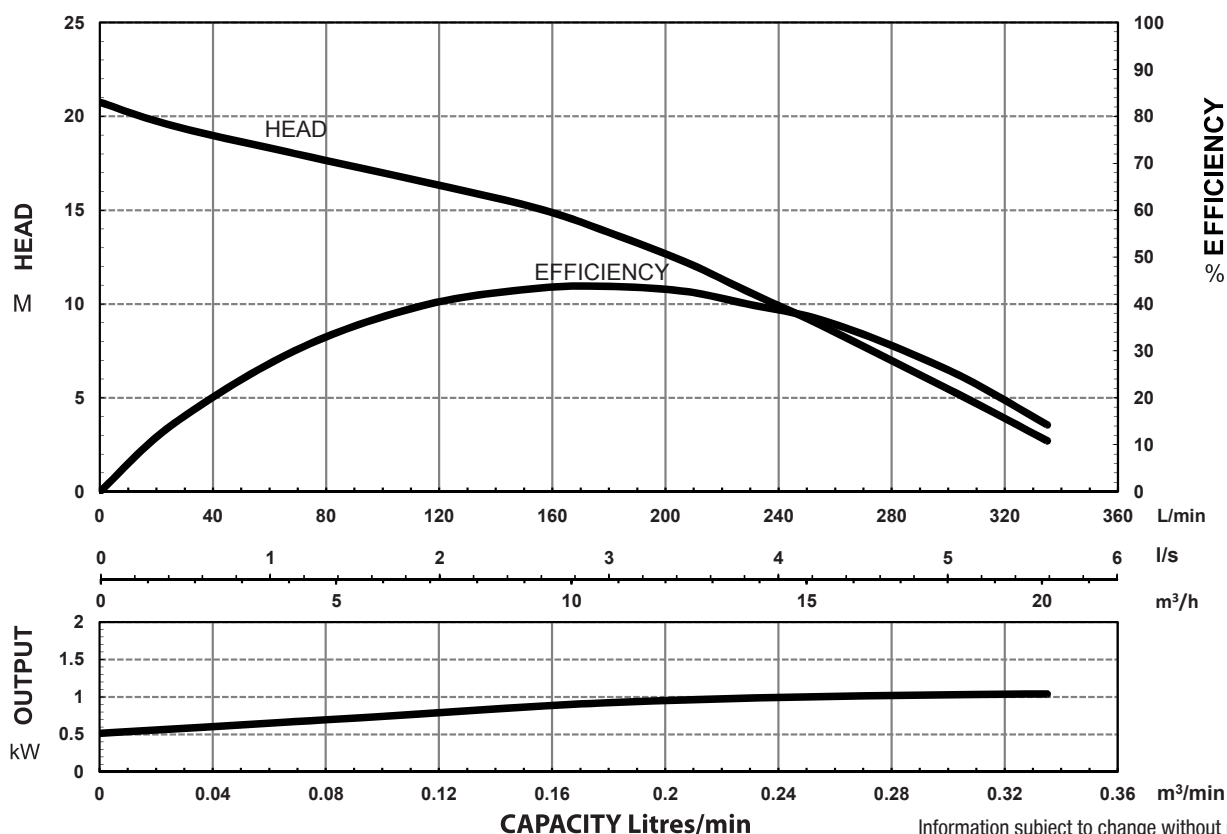

Information subject to change without notice.

SECTIONAL DRAWING & MATERIALS LIST

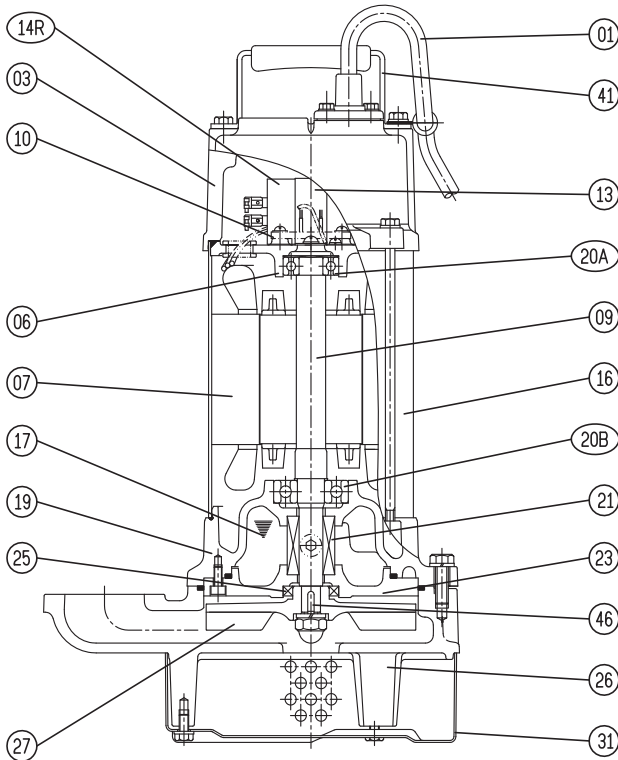

PART NUMBER	DESCRIPTION	MATERIAL
01	Cable	H07RN-F
03	Upper Motor Cap	Cast Iron FC-200
06	Upper Bearing Housing	Cast Iron FC-200
07	Motor Stator	
09	Shaft (With Rotor)	(Shaft) Stainless Steel 410
10	Auto Cut Out Overload	
14R	Capacitor (for 240 volt models, transformer relay for UADZ750/50/3)	
16	Motor Casing	304 Stainless Steel
17	Lubricant	Turbine Oil
19	Lower Bearing Housing	Cast Iron FC-200
20A	Upper Bearing	
20B	Lower Bearing	
21	Mechanical Seal	Upper: Carbon/Ceramic Lower: Silicon/Silicon
23	Mechanical Seal Housing	Cast Iron FC-200
25	Oil Seal	Nitrile
26	Pump Casing	Cast Iron FC-200
27	Impeller	Cast Iron FC-200
31	Strainer	304 Stainless Steel
36	Outlet Flange	Cast Iron FC-200
41	Handle	304 Stainless Steel
46	Impeller Key	304 Stainless Steel
47	O'rings	
55	Oil Plug	304 Stainless Steel
FL	Floatswitch	

When ordering spare parts as above, simply add the pump model number to the part number from the list above. For example, a power lead (part '01'), the complete spare part name would be written as '01-UADN1100/50/1'.

DIMENSIONAL DRAWING

ELBOW (FLANGE) SET

GUIDE RAIL SYSTEM DIMENSIONS USING GR50B GUIDE RAIL KIT

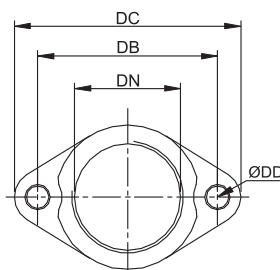
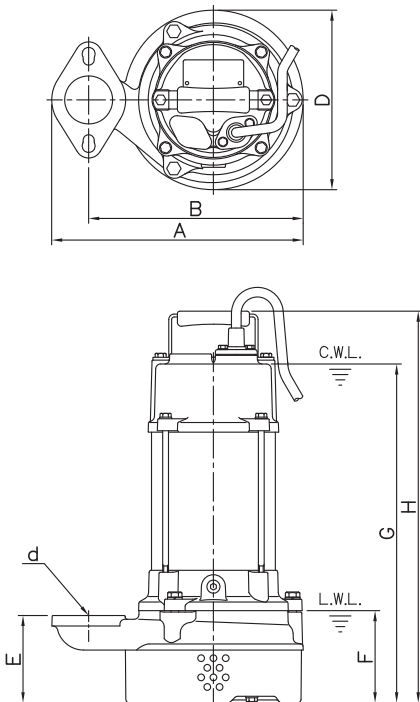

DIMENSIONS - mm

DN	DB	DC	DD
50	96	121	12

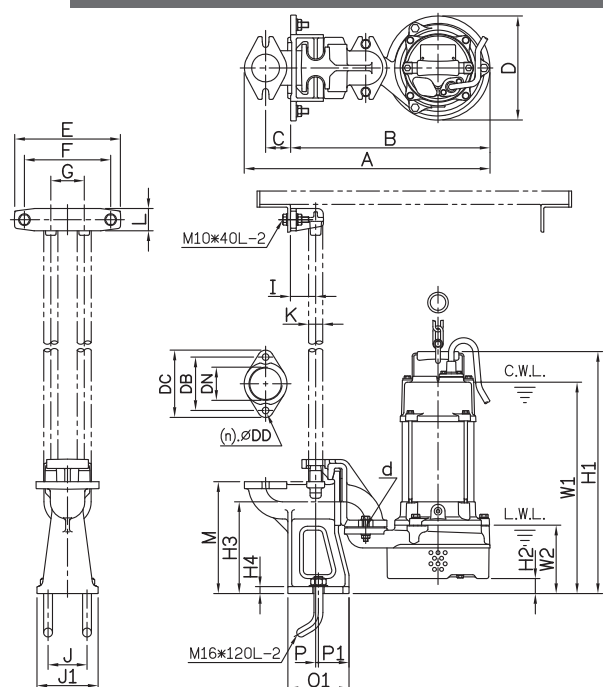

DIMENSIONS - mm

d	A	B	C	D	E	F	G	I	J	J1	K	L	M	O1	P	P1	W1	W2	H1	H2	H3	H4
50	443	359	45	187	190	155	60	45	70	110	19	40	201	110	5	55	400	123	455	27	165	13

DIMENSIONS - mm

d	A	B	D	E	F	G	H
50	262	224	187	91	90	353	408

Information subject to change without notice.