

e-SV Series

VERTICAL MULTISTAGE ELECTRIC PUMPS

EQUIPPED WITH IE2, IE3 MOTORS (REG. (EU) 2019/1781)

ErP 2009/125/EC

Directive 2009/125/EC of the European Union

The **Directive 2005/32/EC** on energy-using products (**EuP**) and the subsequent **Directive 2009/125/EC** on energy-related products (**ErP**) established the ecodesign requirements for products to reduce their energy consumption and consequently their environmental impact.

These requirements apply to products placed and used in the European Economic Area (European Union plus Iceland, Liechtenstein and Norway) as a stand-alone unit or as integrated parts in other products.

The table shows the Regulations that define the requirements for Lowara products::

Product	Regulations	From	Target
Pumps*	(EU) N. 547/2012	1 January 2015	MEI ≥ 0,4
Circulators**	(EC) N. 641/2009, (EU) N. 622/2012 e (EU) 2019/1781	1 August 2015	EEl < 0,23
Electric motors	(EU) 2019/1781 e 2021/341	1 July 2021	IE2 : three-phase motors with a rated output ≥ 0,12 and < 0,749 kW IE3 : three-phase motors with a rated output ≥ 0,75 and < 1000 kW
Variable speed drives (VSD)***	(EU) 2019/1781 e 2021/341	1 July 2021	IE2

* some types of pump, used for pumping clean water.

** circulators with a rated hydraulic output power of between 1 and 2500 W, designed for use in heating systems or in secondary circuits of cooling distribution systems.

*** variable speed drives with three-phase input and rated output power from 0,12 kW up to 1000 kW, rated for operating with motor included in the same regulations.

From 1 July 2023 it will be introduced additional requirements.

CONTENTS

GENERAL INTRODUCTION	5
GENERAL CHARACTERISTICS, 2 POLES	7
TYPICAL APPLICATIONS	8
IDENTIFICATION CODE	9
RATING PLATE	10
1, 3, 5SV SERIES - 10, 15, 22SV SERIES ≤ 4 kW ELECTRIC PUMP CROSS SECTION AND MAIN COMPONENTS..	11
10, 15, 22SV SERIES ≥ 5,5 kW ELECTRIC PUMP CROSS SECTION AND MAIN COMPONENTS.....	12
33, 46, 66, 92SV SERIES ELECTRIC PUMP CROSS SECTION AND MAIN COMPONENTS.....	13
125SV SERIES ELECTRIC PUMP CROSS SECTION AND MAIN COMPONENTS.....	14
MECHANICAL SEALS, ACCORDING TO EN 12756.....	15
MOTORS (ErP 2009/125/EC)	17
PUMPS (ErP 2009/125/EC).....	21
HYDRAULIC PERFORMANCE RANGE AT 50 Hz, 2 POLES	22
DIMENSIONS AND WEIGHTS AT 50 Hz, 2 POLES.....	28
e-SVH: e-SV WITH HYDROVAR.....	53
HYDROVAR (ErP 2009/125/EC)	56
e-SVE: VERSION WITH DRIVE AND PERMANENT MAGNET MOTOR (e-SM DRIVE)	95
ACCESSORIES.....	145
SPECIAL VERSIONS NOT DESCRIBED IN THIS CATALOGUE	152
REPORTS AND DECLARATIONS	153
TECHNICAL APPENDIX.....	155

e-SV SERIES
HYDRAULIC PERFORMANCE RANGE AT 50 Hz

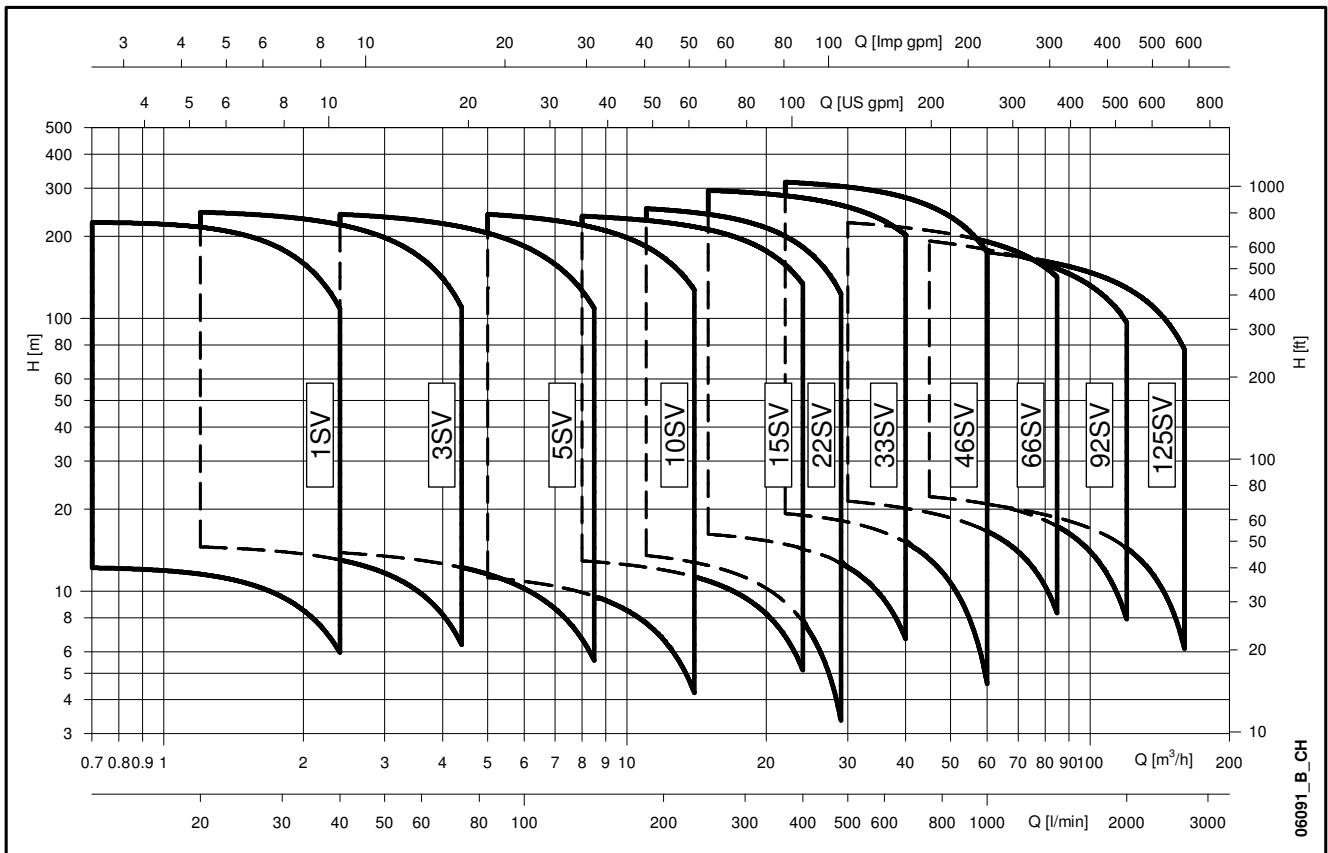

06091_B_CH

e-SV SERIES VERTICAL MULTISTAGE ELECTRIC PUMP

GENERAL INTRODUCTION

The e-SV pump is a non-self priming vertical multistage pump coupled to a standard motor.

The liquid end, located between the upper cover and the pump casing, is held in place by tie rods. The pump casing is available with different configurations and connection types.

MARKET SECTORS

- Civil
- Agricultural
- Light industry
- Water treatment
- Heating and air conditioning.

APPLICATIONS

- Handling of water, free of suspended solids, in the civil, industrial and agricultural sectors.
- Pressure boosting and water supply systems.
- Irrigation systems.
- Wash systems.
- Water treatment plants.
- Handling of moderately aggressive liquids, demineralised water, water and glycol, etc.
- Circulation of hot and cold water for heating, cooling and conditioning systems.
- Boiler feed.
- Pharmaceutical food & beverage industries.

LIQUID END MADE ENTIRELY OF STAINLESS STEEL IN THE 1, 3, 5, 10, 15, 22 m³/h STANDARD VERSION

STANDARD MECHANICAL SEAL CAN BE REPLACED WITHOUT REMOVING THE MOTOR FROM THE PUMP (FOR 10, 15, 22, 33, 46, 66, 92, 125SV)

STANDARD MOTOR FOR POWER EQUAL TO OR ABOVE 3 kW (MEC 132)

CAN BE USED WITH THE HYDROVAR OR THE e-SM DRIVE CONTROL SYSTEM IN ORDER TO MANAGE THE OPERATION OF THE PUMP BASED ON THE SYSTEM CONDITIONS AND SAVE ENERGY



SPECIFICATIONS

PUMP

- Delivery: up to **160 m³/h**.
- Head: up to **330 m**.
- Temperature of pumped liquid:
 - from -30°C to +120°C for standard version.
- Maximum operating **pressure**:
 - 1, 3, 5, 10, 15, 22SV with oval flanges: 16 bar (PN16).
 - 1, 3, 5, 10, 15, 22SV with round flanges or Victaulic®, Clamp or DIN 11851 connections: 25 bar (PN 25).
 - 33, 46SV: 16, 25, 40 bar (PN 16, PN 25 or PN 40).
 - 66, 92, 125SV: 16 or 25 bar (PN 16 or PN 25).
- Hydraulic performance compliant with ISO 9906:2012 - Grade 3B (ex ISO 9906:1999 - Annex A).
- Direction of rotation: clockwise looking at the pump from the top down (marked with an arrow on the adapter and on the coupling).

MOTOR

- Squirrel cage in short circuit, enclosed construction with external ventilation.
- IP55 protection.
- Class 155 (F) insulation.
- Performances according to EN 60034-1.
- Standard voltage:
 - Single-phase version: 220-240 V, 50 Hz.
 - Three-phase version: 220-240/380-415 V, 50 Hz for power up to 3 kW, 380-415/660-690 V, 50 Hz for power above 3 kW.

CHARACTERISTICS OF 1, 3, 5, 10, 15, 22SV SERIES

- Vertical multistage centrifugal pump. All metal parts in contact with the pumped liquid are made of stainless steel.
- The following versions are available:
 - **F**: round flanges, in-line delivery and suction ports, AISI 304.
 - **T**: oval flanges, in-line delivery and suction ports, AISI 304.
 - **R**: round flanges, delivery port above the suction port, with four adjustable positions, AISI 304.
 - **N**: round flanges, in-line delivery and suction ports, AISI 316.
 - **V, P**: Victaulic® couplings, in-line delivery and suction ports, AISI 316.
 - **C**: Clamp couplings (DIN 32676), in-line delivery and suction ports, AISI 316.
 - **K**: threaded couplings, (DIN 11851), in-line delivery and suction ports, AISI 316.
- Reduced axial thrusts enable the use of **standard motors** that are easily found in the market.
- Mechanical seal according to EN 12756 (ex DIN 24960) and ISO 3069 for 1, 3, 5SV and 10, 15, 22SV (\leq of 4 kW) series.
- **Balanced mechanical seal** according to EN 12756 (ex DIN 24960) and ISO 3069, which **can be replaced without removing the motor from the pump** for 10, 15 and 22SV (\geq of 5,5 kW) series.
- Seal housing chamber designed to prevent the accumulation of air in the critical area next to the mechanical seal.
- A second plug is available for 10, 15, 22SV series.
- Versions with round flanges that can be coupled to counter-flanges, according to EN 1092.
- Threaded, oval counter-flanges made of stainless steel are standard supply for the T versions.
- Round counter-flanges made of stainless steel are available on request for the F, R and N versions.
- Easy maintenance. No special tools required for assembly or disassembly.
- **The pumps for drinking water use are WRAS, ACS and D.M. 174 certified for F, T, R, N versions.**
- Standard version for temperatures ranging from -30°C to $+120^{\circ}\text{C}$.

CHARACTERISTICS OF 33, 46, 66, 92, 125SV SERIES

- The following versions are available:
 - **G**: vertical multistage centrifugal pump with impellers, diffusers and outer sleeve made entirely of stainless steel, and with pump casing and motor adaptor made of cast iron.
 - **N, P**: version made entirely of AISI 316 stainless steel.
- Innovative axial load compensation system on pumps with higher head. This ensures reduced axial thrusts and enables the use of **standard motors** that are easily found in the market.
- **Balanced mechanical seal** according to EN 12756 (ex DIN 24960) and ISO 3069, which **can be replaced without removing the motor from the pump**.
- Seal housing chamber designed to prevent the accumulation of air in the critical area next to the mechanical seal.
- **The pumps for drinking water use are WRAS, ACS and D.M. 174 certified for G, N versions.**
- Standard version for temperatures ranging from -30°C to $+120^{\circ}\text{C}$.
- Pump body fitted with couplings for installing pressure gauges on both suction and delivery flanges.
- In-line ports with round flanges that can be coupled to counter-flanges, in compliance with EN 1092.
- Mechanical sturdiness and easy maintenance. No special tools required for assembly or disassembly.

Inlet pressure of the pump plus static pressure of the water within the pump cannot exceed the nominal pressure (PN). Using different motors from those provided could limit inlet pressure. In this event please contact customer services.

AVAILABLE ON REQUEST

Special versions are available to suit many applications. For details see page 152.

e-SV SERIES GENERAL CHARACTERISTICS, 2 POLES

	1SV	3SV	5SV	10SV	15SV	22SV	33SV	46SV	66SV	92SV	125SV
Max efficiency flow (m ³ /h)	1,7	3	5,5	10,5	16,5	20,5	31	43	72	90	120
Flow range (m ³ /h)	0,7÷2,4	1,2÷4,4	2,4÷8,5	5÷14	8÷24	11÷29	15÷40	22÷60	30÷85	45÷120	60÷160
Maximum head (m)	230	250	250	250	250	260	300	360	230	210	220
Motor power (kW)	0,37÷2,2	0,37÷3	0,37÷5,5	0,75÷11	1,1÷15	1,1÷18,5	2,2÷30	3÷45	4÷45	5,5÷45	7,5÷55
Max η (%) of pump	50	60	70	71	72	73	77	79	78	80	78
Standard temperature (°C)	-30 +120										

1-125sv_2p50-en_b_tg

1, 3, 5, 10, 15, 22SV VERSIONS

TYPE		2 POLES					
		1SV	3SV	5SV	10SV	15SV	22SV
F	AISI 304, PN25. IN-LINE PORTS, ROUND FLANGES	•	•	•	•	•	•
T	AISI 304, PN16. IN-LINE PORTS, OVAL FLANGES	•	•	•	•	•	•
R	AISI 304, PN25. DISCHARGE PORT ABOVE SUCTION, ROUND FLANGES	•	•	•	•	•	•
N	AISI 316, PN25. IN-LINE PORTS, ROUND FLANGES	•	•	•	•	•	•
V	AISI 316, PN25. VICTAULIC® COUPLINGS	•	•	•	•	•	•
P	AISI 316, PN40. REINFORCED SLEEVE. VICTAULIC® COUPLINGS	•	•	•	•	•	•
C	AISI 316, PN25. CLAMP COUPLINGS (DIN 32676)	•	•	•	•	•	•
K	AISI 316, PN25. THREADED COUPLINGS (DIN 11851)	•	•	•	•	•	•

• = Available.

1-22sv_2p50-en_c_tc

33, 46, 66, 92, 125SV VERSIONS

TYPE		2 POLES SV				
		33SV	46SV	66SV	92SV	125SV
G	CAST IRON PUMP CASING, LIQUID END MADE OF STAINLESS STEEL, IN-LINE ROUND FLANGES PN16, PN25 OR PN40 DEPENDING ON NUMBER OF STAGES AND MODEL.	•	•	•	•	•
N	ALL AISI 316 STAINLESS STEEL, IN-LINE ROUND FLANGES, PN16, PN25 OR PN40 DEPENDING ON NUMBER OF STAGES AND MODEL.	•	•	•	•	•
P	ALL AISI 316 STAINLESS STEEL. FLANGES, IN-LINE ROUND, PN40. REINFORCED SLEEVE.	•	•	•	•	•

• = Available.

33-125sv_2p50-en_b_tc

VERSION DIAGRAM

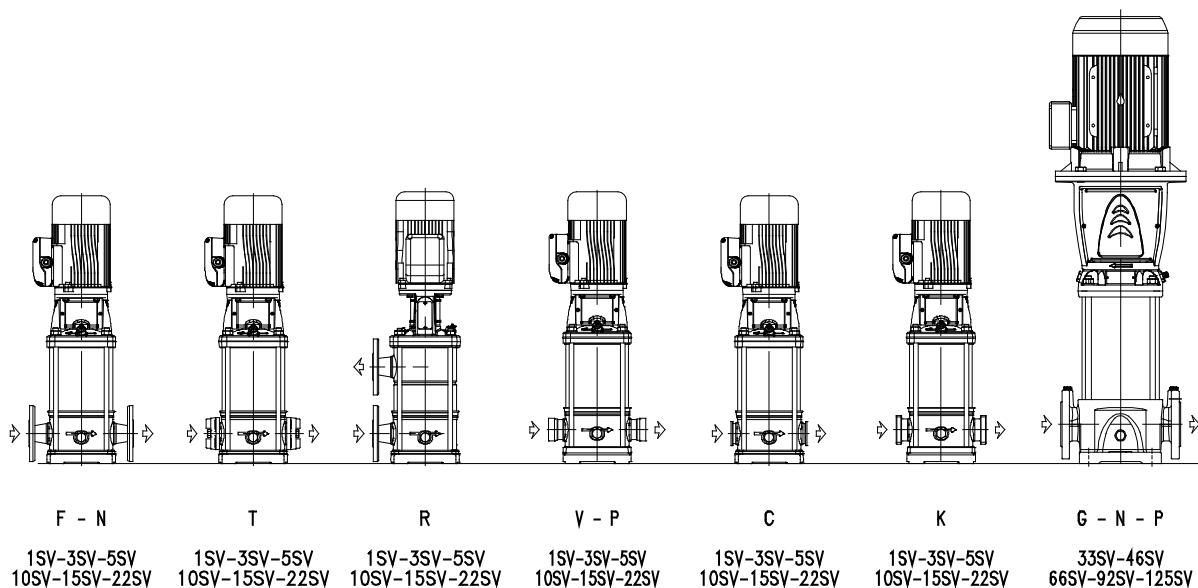

For Dual Pump System (DPS) version, please see e-SV Special Versions catalog.

e-SV SERIES TYPICAL APPLICATIONS

WATER SUPPLY AND PRESSURE BOOSTING

- Pressure boosting in building, hotel, residential complexes.
- Pressure booster stations, supply of water networks.
- Booster packages.

WATER TREATMENT

- Ultrafiltration systems.
- Reverse osmosis systems.
- Water softeners and de-mineralization.
- Distillation systems.
- Filtration.

LIGHT INDUSTRY

- Washing and cleaning plants (washing and degreasing of mechanical parts, car and truck wash tunnels, washing of electronic industry circuits).
- Commercial washers.
- Firefighting system pumps.

PHARMACEUTICAL AND FOOD & BEVERAGE INDUSTRIES

- Production plant where specific sanitary standards are required.

IRRIGATION AND AGRICULTURE

- Greenhouses.
- Humidifiers.
- Sprinkler irrigation.

HEATING, VENTILATION AND AIR CONDITIONING (HVAC)

- Cooling towers and systems.
- Temperature control systems.
- Refrigerators.
- Induction heating.
- Heat exchangers.
- Boilers, water recirculation and heating.

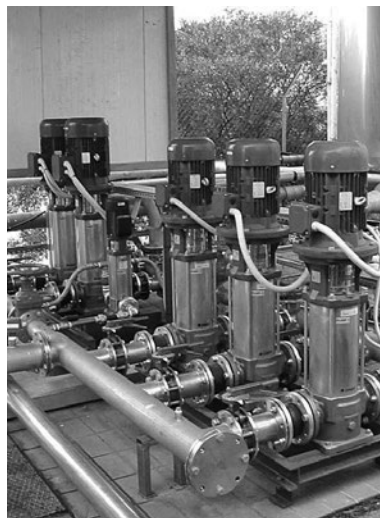

IDENTIFICATION CODE

1, 3, 5, 10, 15, 22SV SERIES

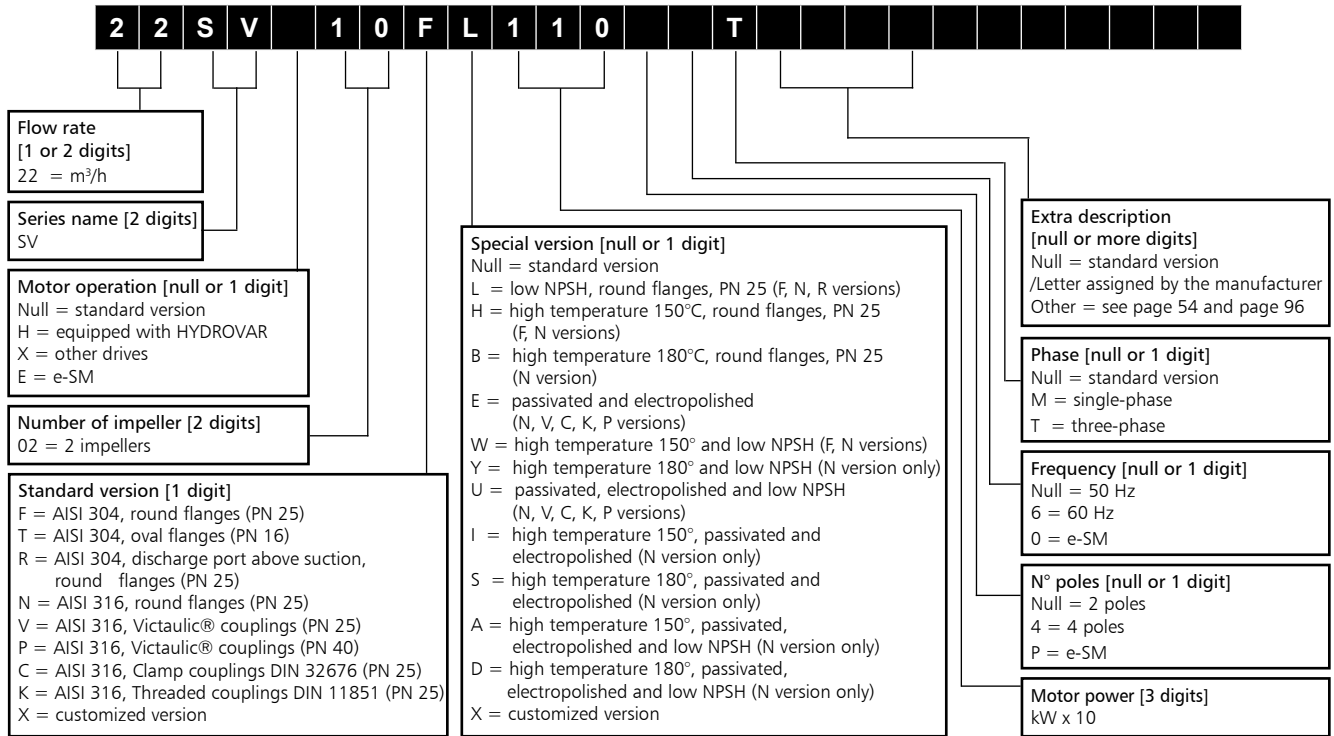

33, 46, 66, 92, 125SV SERIES

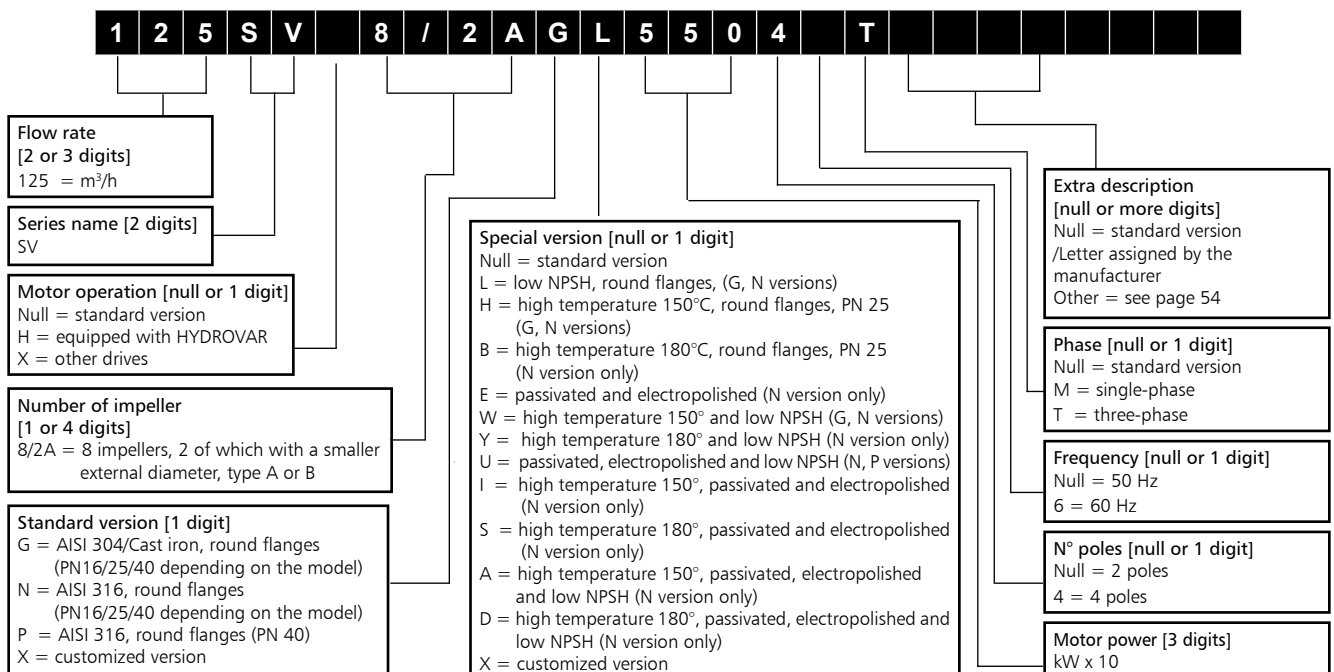

EXAMPLE: 22SV10F110T

e-SV series electric pump, flow rate 22 m³/h, number of impellers 10, F version (AISI 304), round flanges, rated motor power 11 kW, 2 poles, 50 Hz frequency, three-phase.

EXAMPLE: 22SVE02F015P0M/2

e-SV series electric pump, Flow rate 22 m³/h, e-SM (SMART) coupling, number of impellers 2, F version (AISI 304), round flanges, rated motor power 1,5 kW, e-SM motor type, single-phase, e-SM power supply 1x208-240.

EXAMPLE: 125SV8/2AG550T

e-SV series electric pump, flow rate 125 m³/h, number of impellers 8, 2 of which with a smaller external diameter (type A), G version (AISI 304/Cast iron), round flanges, rated motor power 55 kW, 50 Hz frequency, three-phase.

e-SV SERIES RATING PLATE

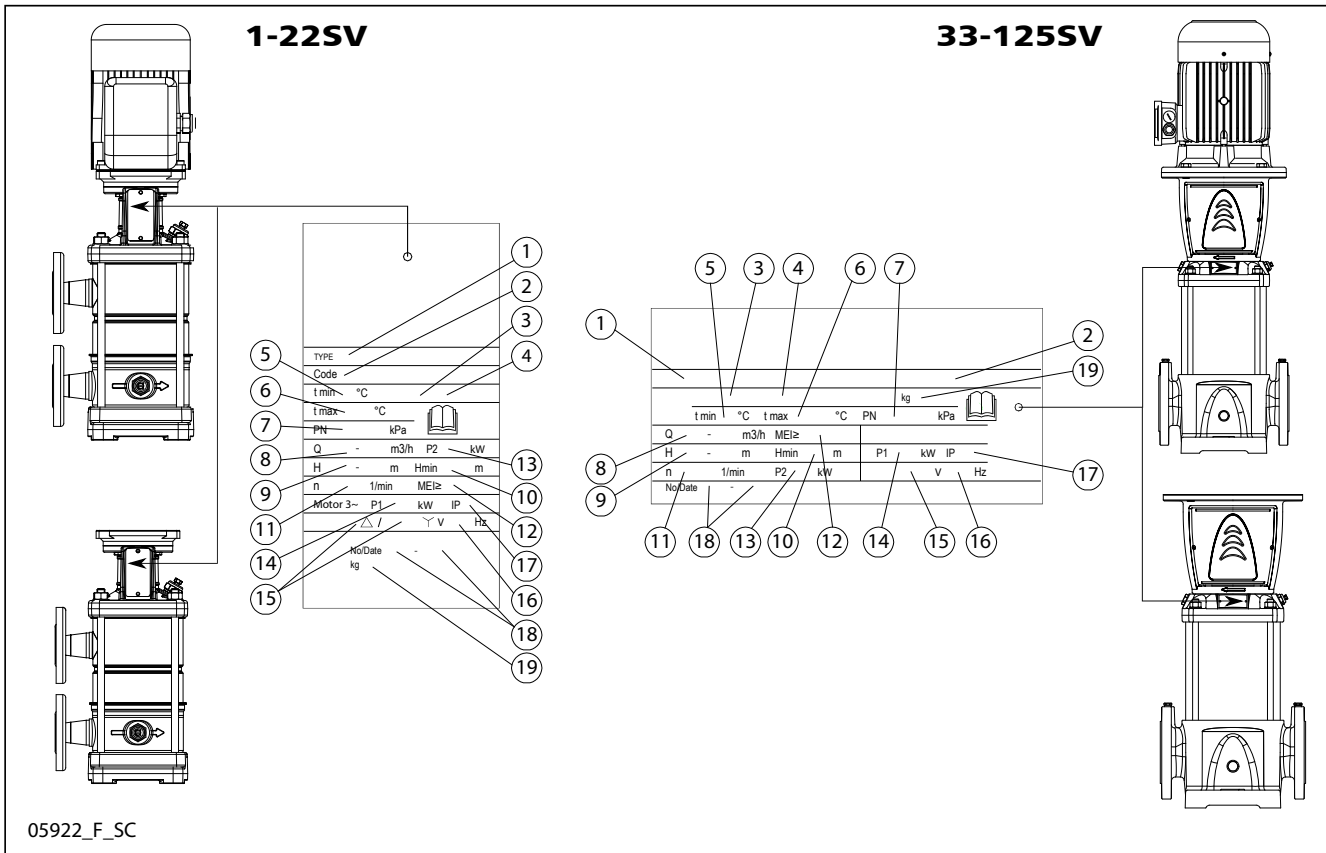

LEGEND

- 1 - Pump / electric pump unit type
 - 2 - Product code
 - 3 - Mechanical seal material identification code
 - 4 - O-ring material identification code
 - 5 - Minimum operating liquid temperature
 - 6 - Maximum operating liquid temperature
 - 7 - Maximum operating pressure
 - 8 - Capacity range
 - 9 - Head range
 - 10 - Minimum head
 - 11 - Speed
 - 12 - Minimum efficiency index
 - 13 - Pump rated power
 - 14 - Pump unit power consumption (*)
 - 15 - Rated voltage range (*)
 - 16 - Frequency (*)
 - 17 - Protection class (*)
 - 18 - Serial number + manufacturing date
 - 19 - Weight
- (*) Data present only on the pump rating plate

Additional liquid temperature plate

It is applied on the units where the maximum working temperature of the liquid exceeds the limit of 90°C (194°F), foreseen by the standard EN 60335-2-41, with $U_n (V) \leq 480 V (3\sim)$ or $\leq 250 V (1\sim)$.

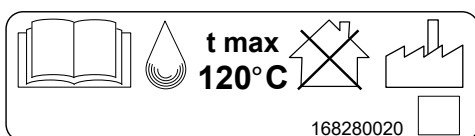

1, 3, 5SV SERIES - 10, 15, 22SV SERIES ≤ 4 kW ELECTRIC PUMP CROSS SECTION AND MAIN COMPONENTS

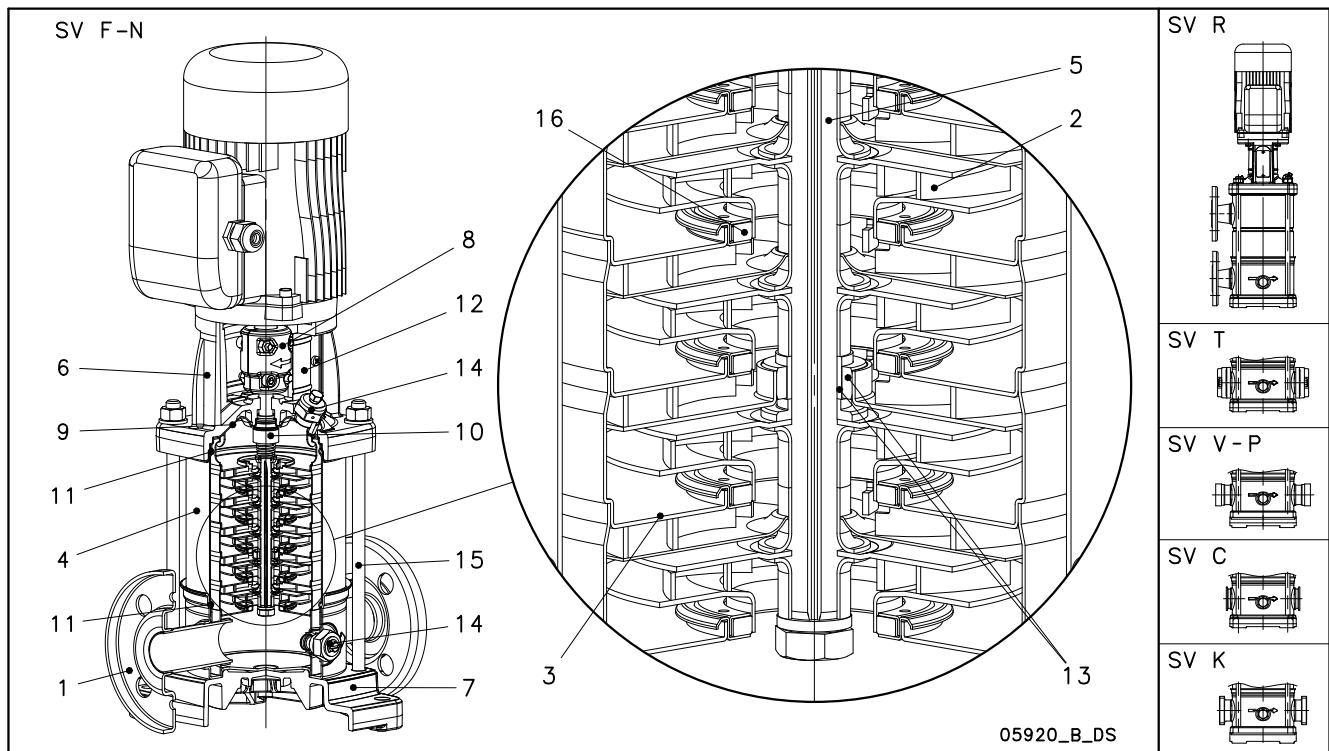

F, T, R VERSIONS

REF. N.	NAME	MATERIAL	REFERENCE STANDARDS	
			EUROPE	USA
1	Pump body	Stainless steel	EN 10088-1-X5CrNi18-10 (1.4301)	AISI 304
2	Impeller	Stainless steel	EN 10088-1-X5CrNi18-10 (1.4301)	AISI 304
3	Diffuser	Stainless steel	EN 10088-1-X5CrNi18-10 (1.4301)	AISI 304
4	Outer sleeve	Stainless steel	EN 10088-1-X5CrNi18-10 (1.4301)	AISI 304
5	Shaft	Stainless steel	EN 10088-1-X5CrNi18-10 (1.4301)	AISI 304
6	Adapter	Cast iron	EN 1561-GJL-250 (JL1040)	ASTM Class 35
7	Base	Aluminium	EN 1706-AC-AISI11Cu2 (Fe) (AC46100)	-
8	Coupling	Aluminium	EN 1706-AC-AISI11Cu2 (Fe) (AC46100)	-
9	Seal housing	Stainless steel	EN 10088-1-X5CrNi18-10 (1.4301)	AISI 304
10	Mechanical seal	Silicon carbide / Carbon / EPDM		
11	Elastomers	EPDM		
12	Coupling protection	Stainless steel	EN 10088-1-X5CrNi18-10 (1.4301)	AISI 304
13	Shaft sleeve and bushing	Tungsten carbide		
14	Fill / drain plugs	Stainless steel	EN 10088-1-X5CrNi18-10 (1.4301)	AISI 304
15	Tie rods	Galvanized steel	EN 10277-3-36SMnPb14 (1.0765)	
16	Wear ring	Technopolymer PPS		

N, V, C, K VERSIONS

1-22sv-frm-en_a_tm

REF. N.	NAME	MATERIAL	REFERENCE STANDARDS	
			EUROPE	USA
1	Pump body	Stainless steel	EN 10088-1-X2CrNiMo17-12-2 (1.4404)	AISI 316L
2	Impeller	Stainless steel	EN 10088-1-X2CrNiMo17-12-2 (1.4404)	AISI 316L
3	Diffuser and upper spacer	Stainless steel	EN 10088-1-X2CrNiMo17-12-2 (1.4404)	AISI 316L
4	Outer sleeve	Stainless steel	EN 10088-1-X2CrNiMo17-12-2 (1.4404)	AISI 316L
5	Shaft	Stainless steel	EN 10088-1-X5CrNiMo17-12-2 (1.4401)	AISI 316
6	Adapter	Cast iron	EN 1561-GJL-250 (JL1040)	ASTM Class 35
7	Base	Aluminium	EN 1706-AC-AISI11Cu2 (Fe) (AC46100)	-
8	Coupling	Aluminium	EN 1706-AC-AISI11Cu2 (Fe) (AC46100)	-
9	Seal housing	Stainless steel	EN 10088-1-X2CrNiMo17-12-2 (1.4404)	AISI 316L
10	Mechanical seal	Silicon carbide / Carbon / EPDM		
11	Elastomers	EPDM		
12	Coupling protection	Stainless steel	EN 10088-1-X5CrNi18-10 (1.4301)	AISI 304
13	Shaft sleeve and bushing	Tungsten carbide		
14	Fill / drain plugs	Stainless steel	EN 10088-1-X5CrNiMo17-12-2 (1.4401)	AISI 316
15	Tie rods	Stainless steel	EN 10088-1-X17CrNi16-2 (1.4057)	AISI 431
16	Wear ring	Technopolymer PPS		

1-22sv-nvck-en_a_tm

10, 15, 22SV SERIES ≥ 5,5 kW

ELECTRIC PUMP CROSS SECTION AND MAIN COMPONENTS

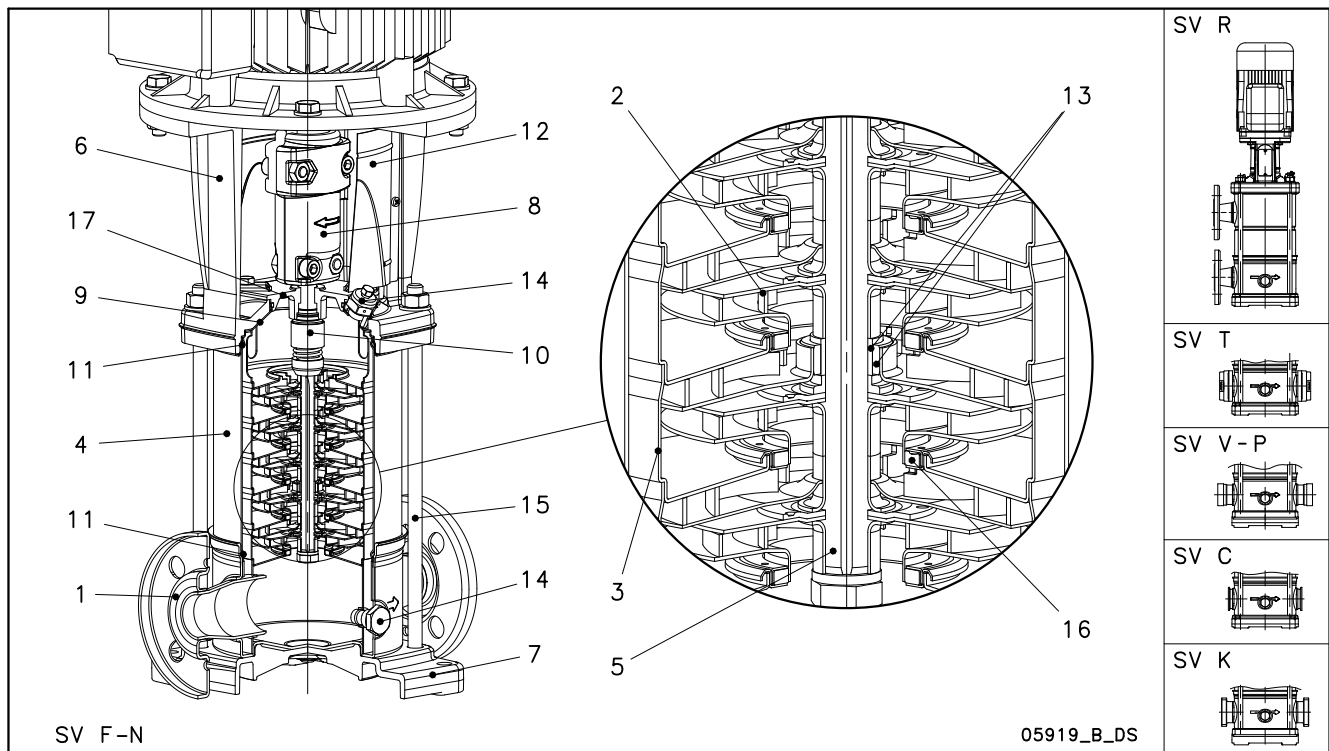

F, T, R VERSIONS

REF. N.	NAME	MATERIAL	REFERENCE STANDARDS	
			EUROPE	USA
1	Pump body	Stainless steel	EN 10088-1-X5CrNi18-10 (1.4301)	AISI 304
2	Impeller	Stainless steel	EN 10088-1-X5CrNi18-10 (1.4301)	AISI 304
3	Diffuser	Stainless steel	EN 10088-1-X5CrNi18-10 (1.4301)	AISI 304
4	Outer sleeve	Stainless steel	EN 10088-1-X5CrNi18-10 (1.4301)	AISI 304
5	Shaft	Stainless steel	EN 10088-1-X5CrNi18-10 (1.4301)	AISI 304
6	Adapter	Cast iron	EN 1561-GJL-250 (JL1040)	ASTM Class 35
7	Base	Aluminium	EN 1706-AC-AISI11Cu2 (Fe) (AC46100)	-
8	Coupling	Aluminium	EN 1706-AC-AISI11Cu2 (Fe) (AC46100)	-
9	Seal plate	Stainless steel	EN 10088-1-X5CrNi18-10 (1.4301)	AISI 304
10	Mechanical seal	Silicon carbide / Carbon / EPDM		
11	Elastomers	EPDM		
12	Coupling protection	Stainless steel	EN 10088-1-X5CrNi18-10 (1.4301)	AISI 304
13	Shaft sleeve and bushing	Tungsten carbide		
14	Fill / drain plugs	Stainless steel	EN 10088-1-X5CrNi18-10 (1.4301)	AISI 304
15	Tie rods	Stainless steel	EN 10277-3-36SMnPb14 (1.0765)	
16	Wear ring	Technopolymer PPS		
17	Seal gland	Stainless steel	EN 10213-4-GX5CrNi19-10 (1.4308)	AISI 304

N, V, C, K VERSIONS

10-22sv-fr-en_a_tm

REF. N.	NAME	MATERIAL	REFERENCE STANDARDS	
			EUROPE	USA
1	Pump body	Stainless steel	EN 10088-1-X2CrNiMo17-12-2 (1.4404)	AISI 316L
2	Impeller	Stainless steel	EN 10088-1-X2CrNiMo17-12-2 (1.4404)	AISI 316L
3	Diffuser	Stainless steel	EN 10088-1-X2CrNiMo17-12-2 (1.4404)	AISI 316L
4	Outer sleeve	Stainless steel	EN 10088-1-X2CrNiMo17-12-2 (1.4404)	AISI 316L
5	Shaft	Stainless steel	EN 10088-1-X5CrNiMo17-12-2 (1.4401)	AISI 316
6	Adapter	Cast iron	EN 1561-GJL-250 (JL1040)	ASTM Class 35
7	Base	Aluminium	EN 1706-AC-AISI11Cu2 (Fe) (AC46100)	-
8	Coupling	Aluminium	EN 1706-AC-AISI11Cu2 (Fe) (AC46100)	-
9	Seal plate	Stainless steel	EN 10088-1-X2CrNiMo17-12-2 (1.4404)	AISI 316L
10	Mechanical seal	Silicon carbide / Carbon / EPDM		
11	Elastomers	EPDM		
12	Coupling protection	Stainless steel	EN 10088-1-X5CrNi18-10 (1.4301)	AISI 304
13	Shaft sleeve and bushing	Tungsten carbide		
14	Fill / drain plugs	Stainless steel	EN 10088-1-X5CrNiMo17-12-2 (1.4401)	AISI 316
15	Tie rods	Stainless steel	EN 10088-1-X17CrNi16-2 (1.4057)	AISI 431
16	Wear ring	Technopolymer PPS		
17	Seal gland	Stainless steel	EN 10213-4-GX5CrNiMo19-11-2 (1.4408)	AISI 316

10-22sv-nvck-en_a_tm

33, 46, 66, 92SV SERIES ELECTRIC PUMP CROSS SECTION AND MAIN COMPONENTS

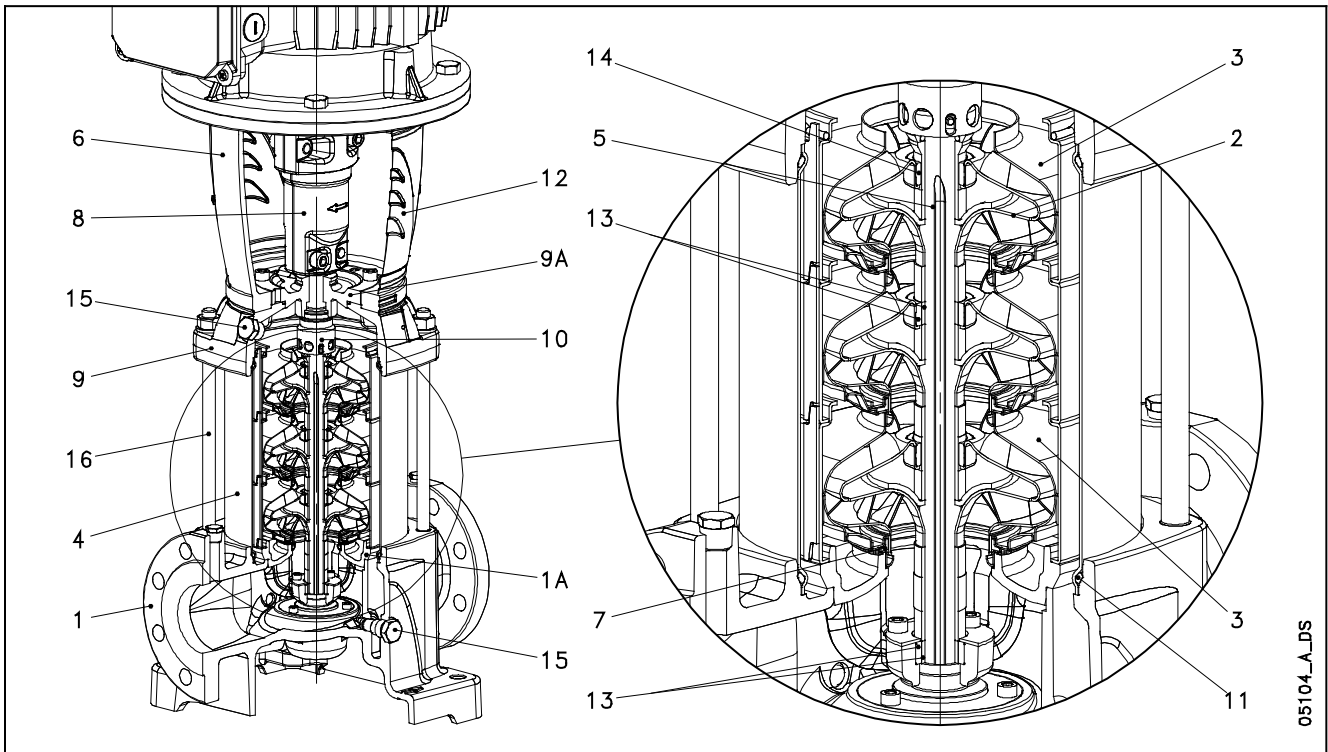

05104_A_DS

G VERSIONS

REF. N.	NAME	MATERIAL	REFERENCE STANDARDS	
			EUROPE	USA
1	Pump body	Cast iron	EN 1561-GJL-250 (JL1040)	ASTM Class 35
1A	Lower support	Cast iron	EN 1561-GJL-250 (JL1040)	ASTM Class 35
2	Impeller	Stainless steel	EN 10088-1-X2CrNiMo17-12-2 (1.4404)	AISI 316L
3	Diffuser	Stainless steel	EN 10088-1-X5CrNi18-10 (1.4301)	AISI 304
4	Outer sleeve	Stainless steel	EN 10088-1-X5CrNi18-10 (1.4301)	AISI 304
5	Shaft	Stainless steel	EN 10088-1 - X17CrNi16-2 (1.4057)	AISI 431
6	Adapter	Cast iron	EN 1561-GJL-200 (JL1030)	ASTM Class 25
7	Wear ring	Technopolymer PPS		
8	Coupling	Cast iron	EN 1561-GJL-200 (JL1030)	ASTM Class 25
9	Upper head	Cast iron	EN 1561-GJL-250 (JL1040)	ASTM Class 35
9A	Seal housing	Cast iron	EN 1561-GJL-250 (JL1040)	ASTM Class 35
10	Mechanical seal	Silicon carbide / Carbon / EPDM		
11	Elastomers	EPDM		
12	Coupling protection	Stainless steel	EN 10088-1-X5CrNi18-10 (1.4301)	AISI 304
13	Shaft sleeve and bushing	Tungsten carbide		
14	Bushing for diffuser	Carbon		
15	Fill / Drain plugs	Stainless steel	EN 10088-1-X5CrNiMo17-12-2 (1.4401)	AISI 316
16	Tie rods	Galvanized steel	EN 10277-3-36SMnPb14 (1.0765)	-

N VERSIONS

33-92sv-g-en_a_tm

REF. N.	NAME	MATERIAL	REFERENCE STANDARDS	
			EUROPE	USA
1	Pump body	Stainless steel	EN 10213-4-GX5CrNiMo19-11-2 (1.4408)	ASTM CF8M (AISI 316 cast)
1A	Lower support	Stainless steel	EN 10213-4-GX5CrNiMo19-11-2 (1.4408)	ASTM CF8M (AISI 316 cast)
2	Impeller	Stainless steel	EN 10088-1-X2CrNiMo17-12-2 (1.4404)	AISI 316L
3	Diffuser	Stainless steel	EN 10088-1-X2CrNiMo17-12-2 (1.4404)	AISI 316L
4	Outer sleeve	Stainless steel	EN 10088-1-X2CrNiMo17-12-2 (1.4404)	AISI 316L
5	Shaft	Duplex stainless steel	EN 10088-1-X2CrNiMoN22-5-3 (1.4462)	UNS S 31803
6	Adapter	Cast iron	EN 1561-GJL-200 (JL1030)	ASTM Class 25
7	Wear ring	Technopolymer PPS		
8	Coupling	Cast iron	EN 1561-GJL-200 (JL1030)	ASTM Class 25
9	Upper head	Stainless steel	EN 10213-4-GX5CrNiMo19-11-2 (1.4408)	ASTM CF8M (AISI 316 cast)
9A	Seal housing	Stainless steel	EN 10213-4-GX5CrNiMo19-11-2 (1.4408)	ASTM CF8M (AISI 316 cast)
10	Mechanical seal	Silicon carbide / Carbon / EPDM		
11	Elastomers	EPDM		
12	Coupling protection	Stainless steel	EN 10088-1-X5CrNi18-10 (1.4301)	AISI 304
13	Shaft sleeve and bushing	Tungsten carbide		
14	Bushing for diffuser	Carbon		
15	Fill / drain / air plugs	Stainless steel	EN 10088-1-X5CrNiMo17-12-2 (1.4401)	AISI 316
16	Tie rods	Stainless steel	EN 10088-1-X17CrNi16-2 (1.4057)	AISI 431

33-92sv-n-en_a_tm

125SV SERIES

ELECTRIC PUMP CROSS SECTION AND MAIN COMPONENTS

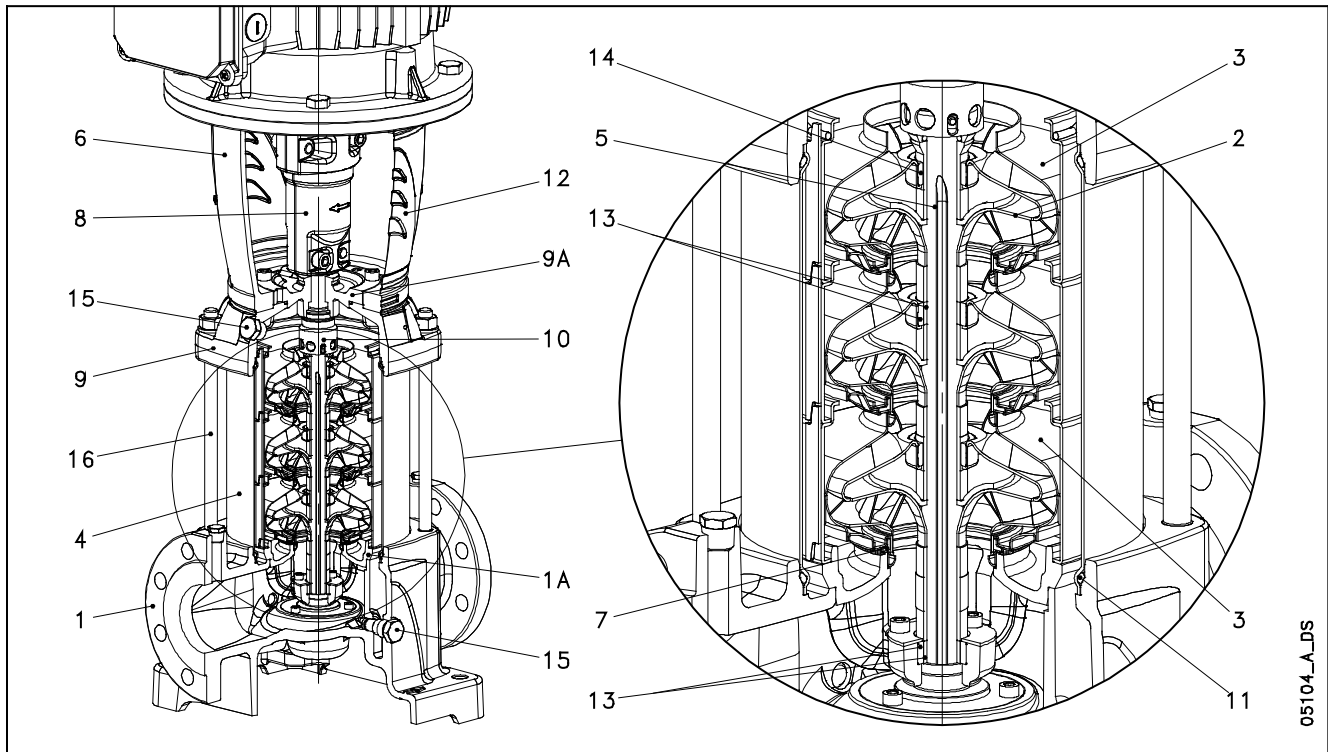

05104_A_DS

G VERSIONS

REF. N.	NAME	MATERIAL	REFERENCE STANDARDS	
			EUROPE	USA
1	Pump body	Cast iron	EN 1561-GJL-250 (JL1040)	ASTM Class 35
1A	Lower support	Stainless steel	EN 10213-GX5CrNi19-10 (1.4308)	AISI 304
2-3	Impeller, Diffuser	Stainless steel	EN 10213-GX5CrNi19-10 (1.4308)	AISI 304
4	Outer sleeve	Stainless steel	EN 10088-1-X5CrNi18-10 (1.4301)	AISI 304
5	Shaft	Stainless steel	EN 10088-1 - X17CrNi16-2 (1.4057)	AISI 431
6	Adapter (up to 45kW)	Cast iron	EN 1561-GJL-200 (JL1030)	ASTM Class 25
6	Adapter (for higher powers)	Cast iron	EN 1563-GJS-500-7 (JS1050)	ASTM A 536 80-55-06
7	Wear ring	Technopolymer PPS		
8	Coupling (up to 45kW)	Cast iron	EN 1561-GJL-200 (JL1030)	ASTM Class 25
8	Coupling (for higher powers)	Cast iron	EN 1563-GJS-500-7 (JS1050)	ASTM A 536 80-55-06
9-9A	Upper head, Seal housing	Cast iron	EN 1561-GJL-250 (JL1040)	ASTM Class 35
10	Mechanical seal	Silicon carbide / Carbon / EPDM		
11	Elastomers	EPDM		
12	Coupling protection	Stainless steel	EN 10088-1-X5CrNi18-10 (1.4301)	AISI 304
13	Shaft sleeve and bushing	Tungsten carbide		
14	Bushing for diffuser	Carbon		
15	Fill / drain / air plugs	Stainless steel	EN 10088-1-X5CrNiMo17-12-2 (1.4401)	AISI 316
16	Tie rods	Galvanized steel	EN 10277-3-365MnPb14 (1.0765)	-
17	Adapter ring	Stainless steel	EN 10213-GX5CrNi19-10 (1.4308)	AISI 304

N VERSIONS

125sv-g-en_a_tm

REF. N.	NAME	MATERIAL	REFERENCE STANDARDS	
			EUROPE	USA
1	Pump body	Stainless steel	EN 10213-4-GX5CrNiMo19-11-2 (1.4408)	ASTM CF8M (AISI 316)
1A	Lower support	Stainless steel	EN 10213-4-GX5CrNiMo19-11-2 (1.4408)	ASTM CF8M (AISI 316)
2-3	Impeller, Diffuser	Stainless steel	EN 10213-4-GX5CrNiMo19-11-2 (1.4408)	ASTM CF8M (AISI 316)
4	Outer sleeve	Stainless steel	EN 10088-1-X2CrNiMo17-12-2 (1.4404)	AISI 316L
5	Shaft	Duplex stainless steel	EN 10088-1-X2CrNiMoN22-5-3 (1.4462)	UNS S 31803
6	Adapter	Cast iron	EN 1561-GJL-200 (JL1030)	ASTM Class 25
6	Adapter	Cast iron	EN 1563-GJS-500-7 (JS1050)	
7	Wear ring	Technopolymer PPS		
8	Coupling	Cast iron	EN 1561-GJL-200 (JL1030)	ASTM Class 25
8	Coupling	Cast iron	EN 1563-GJS-500-7 (JS1050)	
9-9A	Upper head, Seal housing	Stainless steel	EN 10213-4-GX5CrNiMo19-11-2 (1.4408)	ASTM CF8M (AISI 316)
10	Mechanical seal	Silicon carbide / Carbon / EPDM		
11	Elastomers	EPDM		
12	Coupling protection	Stainless steel	EN 10088-1-X5CrNi18-10 (1.4301)	AISI 304
13	Shaft sleeve and bushing	Tungsten carbide		
14	Bushing for diffuser	Carbon		
15	Fill / drain / air plugs	Stainless steel	EN 10088-1-X5CrNiMo17-12-2 (1.4401)	AISI 316
16	Tie rods	Stainless steel	EN 10088-1-X17CrNi16-2 (1.4057)	AISI 431
17	Adapter ring	Stainless steel	EN 10213-4-GX5CrNiMo19-11-2 (1.4408)	ASTM CF8M (AISI 316)

125sv-n-en_a_tm

e-SV SERIES MECHANICAL SEALS, ACCORDING TO EN 12756

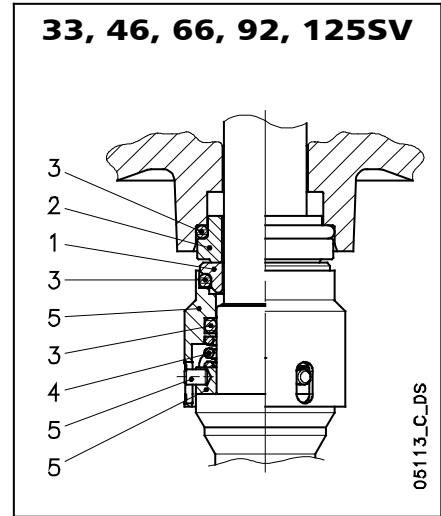
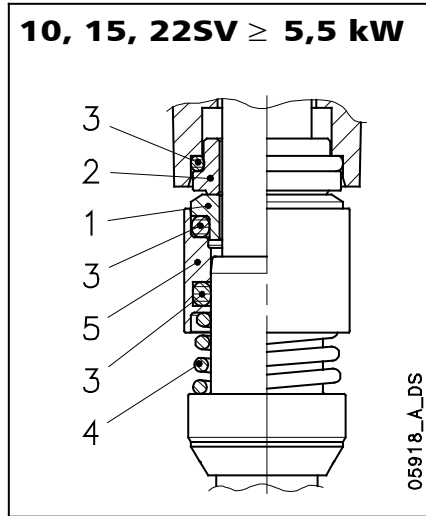
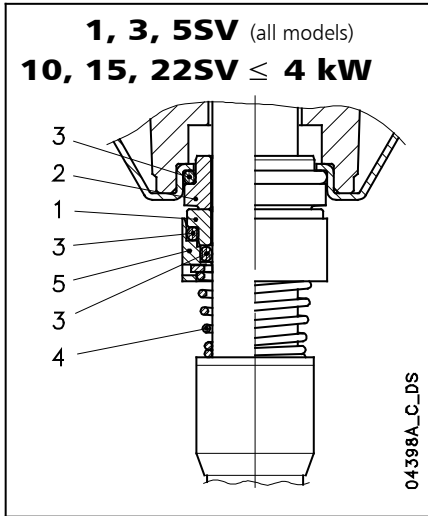

LIST OF MATERIALS

POSITION 1 - 2	POSITION 3	POSITION 4 - 5
Q ₁ : Silicon Carbide	E : EPDM	G : AISI 316
B : Resin impregnated carbon	V : FKM (FPM)	
C : Special resin impregnated carbon	T : PTFE	

TYPE OF SEAL

sv_ten-mec-en_b_tm

TYPE	POSITION					TEMPERATURE (°C)
	1 ROTATING PART	2 STATIONARY PART	3 ELASTOMERS	4 SPRINGS	5 OTHER COMPONENTS	
STANDARD MECHANICAL SEAL						
Q ₁ B E G G	Q ₁	B	E	G	G	-30 +120
OTHER TYPES OF AVAILABLE MECHANICAL SEAL						
Q ₁ Q ₁ E G G	Q ₁	Q ₁	E	G	G	-30 +120
Q ₁ B V G G	Q ₁	B	V	G	G	-10 +120
Q ₁ Q ₁ V G G	Q ₁	Q ₁	V	G	G	-10 +120
*Q ₁ C T G G	Q ₁	C	T	G	G	0 +120
*Q ₁ Q ₁ T G G	Q ₁	Q ₁	T	G	G	0 +120

* Versions with anti-rotation lock pin of the fixed part.

sv_tipi-ten-mec-en_b_tc

PRESSURE/TEMPERATURE APPLICATION LIMITS FOR COMPLETE PUMP

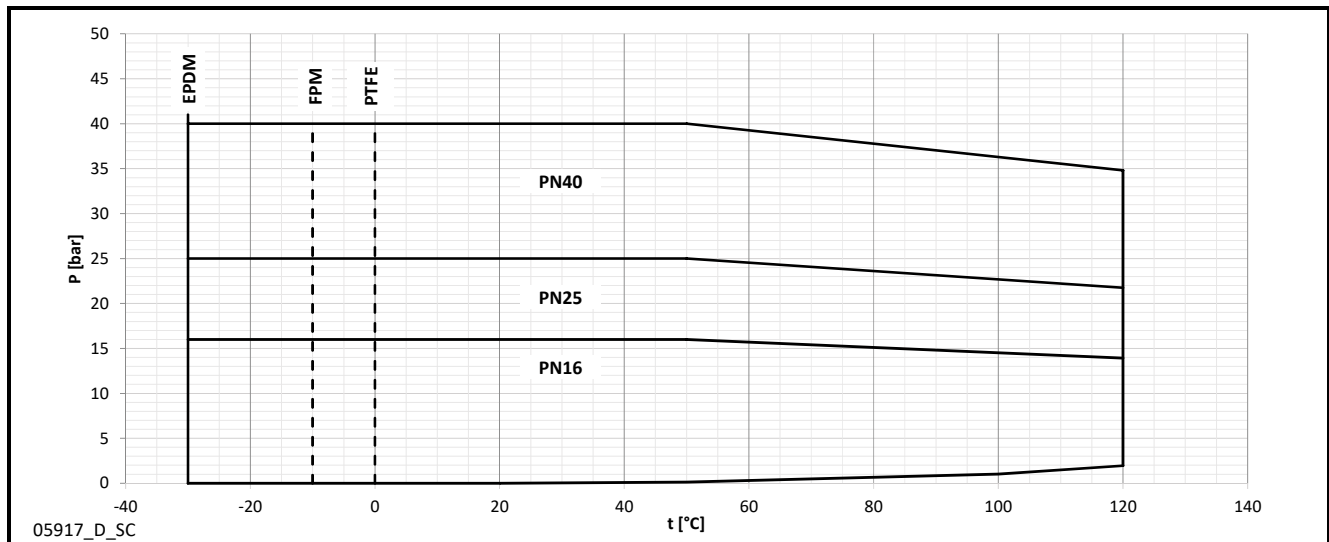

COMPATIBILITY CHART FOR MATERIALS IN CONTACT WITH MOST COMMONLY USED LIQUIDS

LIQUID	CONCENTRATION (%)	TEMPERAT. MIN/MAX (°C)	SPECIF. WEIGHT (Kg/dm ³)	1, 3, 5, 10, 15, 22 SV		33, 46, 66, 92, 125 SV		RECOMMEND. SEAL	ELASTOM.
				VERSION Standard	N	VERSION Standard	N		
Acetic acid	80	-10 +70	1,05	•	•		•	Q ₁ BEGG	E
Alkaline degreaser	5	80		•	•	•	•	Q ₁ Q ₁ VGG	V
Aluminium sulfate	30	-5 +50	2,71		•		•	Q ₁ Q ₁ EGG	E
Ammonia in water	25	-20 +50	0,99	•	•		•	Q ₁ BEGG	E
Ammonium sulfate	10	-10 +60	1,77		•		•	Q ₁ Q ₁ EGG	E
Benzoic acid	70	0 +70	1,31	•	•		•	Q ₁ BVGG	V
Boric acid	saturated	-10 +90	1,43	•	•		•	Q ₁ Q ₁ VGG	V
Butyl alcohol	100	-5 +80	0,81	•	•	•	•	Q ₁ BVGG	V
Caustic soda	25	0 +70	2,13	•	•	•	•	Q ₁ Q ₁ EGG	E
Chloroform	100	-10 +30	1,48	•	•	•	•	Q ₁ BVGG	V
Citric acid	5	-10 +70	1,54	•	•		•	Q ₁ BEGG	E
Cleaning products	10	-5 +100		•	•	•	•	Q ₁ Q ₁ VGG	V
Copper sulfate	20	0 +30	2,28		•		•	Q ₁ Q ₁ VGG	V
Cutting fluid	100	-5 +110	0,90	•	•	•	•	Q ₁ BVGG	V
Deionised, demineralised water	100	-25 +110	1	•	•	•	•	Q ₁ BEGG	E
Denatured alcohol	100	-5 +70	0,81	•	•	•	•	Q ₁ BEGG	E
Diathermic oil	100	-5 +110	0,90	•	•	•	•	Q ₁ BVGG	V
Emulsion oil and water	any	-5 +90		•	•	•	•	Q ₁ BVGG	V
Ethyl alcohol	100	-5 +40	0,81	•	•	•	•	Q ₁ BEGG	E
Ethylene glycol	30	-30 +120			•		•	Q ₁ BEGG	E
Formaldehyde	100	0 +30	1,13	•	•	•	•	Q ₁ Q ₁ TGG	T
Formic acid	5	-15 +25	1,22	•	•		•	Q ₁ BEGG	E
Glycerine	100	+20 +90	1,26	•	•	•	•	Q ₁ BEGG	E
Hydraulic oil	100	-5 +110		•	•	•	•	Q ₁ BVGG	V
Hydrochloric acid	2	-5 +25	1,20		•		•	Q ₁ Q ₁ VGG	V
Hydroxide sodium	25	0 +70		•	•	•	•	Q ₁ Q ₁ EGG	E
Iron sulfate	10	-5 +30	2,09		•		•	Q ₁ BEGG	E
Methyl alcohol	100	-5 +40	0,79	•	•	•	•	Q ₁ BEGG	E
Mineral oil	100	-5 +110	0,94	•	•	•	•	Q ₁ BVGG	V
Nitric acid	50	-5 +30	1,48	•	•		•	Q ₁ Q ₁ VGG	V
Perchloroethylene	100	-10 +30	1,60	•	•	•	•	Q ₁ BVGG	V
Phosphates-polyphosphates	10	-5 +90			•		•	Q ₁ Q ₁ VGG	V
Phosphoric acid	10	-5 +30	1,33		•		•	Q ₁ BEGG	E
Propyl alcohol (Propanol)	100	-5 +80	0,80	•	•	•	•	Q ₁ BEGG	E
Propylene glycol	30	-30 +120		•	•	•	•	Q ₁ BEGG	E
Sodium bicarbonate (Baking soda)	saturated				•		•	Q ₁ BEGG	E
Sodium hypochlorite	1	-10 +25			•		•	Q ₁ Q ₁ VGG	V
Sodium nitrate	saturated	-10 +80	2,25	•	•	•	•	Q ₁ BEGG	E
Sodium sulfate	15	-10 +40	2,60	•	•	•	•	Q ₁ Q ₁ EGG	E
Sulphuric acid	2	-10 +25	1,84		•		•	Q ₁ BVGG	V
Tannic acid	20	0 +50			•		•	Q ₁ BEGG	E
Tartaric acid	50	-10 +25	1,76	•	•		•	Q ₁ Q ₁ VGG	V
Trichloroethylene	100	-10 +40	1,46	•	•	•	•	Q ₁ BVGG	V
Uric acid	80	-10 +80	1,89	•	•		•	Q ₁ BEGG	E
Vegetable oil	100	-5 +110	0,95	•	•	•	•	Q ₁ BEGG	E
Water	100	-5 +120		•	•	•	•	Q ₁ BEGG	E
Water condensate	100	-5 +100	1	•	•	•	•	Q ₁ BEGG	E
Water detergents, mineral oils mixture	10	-5 +80		•	•	•	•	Q ₁ Q ₁ VGG	V

tab-comp-sv-en_b_tm

The above table indicates the compatibility of materials depending on the pumped liquid. Check the specific weight of the liquid or the viscosity as this could affect the power input of the motor and hydraulic performance. For further details, please contact the sales network.

e-SV SERIES MOTORS (ErP 2009/125/EC)

- Short-circuit squirrel-cage motor, enclosed construction with external ventilation (TEFC).
- **IP55** protection degree.
- Insulation class **155 (F)**.
- Electrical performances according to EN 60034-1.
- **Supplied three-phase surface motors with IE2 efficiency level for power < 0,75 kW, IE3 efficiency level for power ≥ 0,75 kW as standard according to EN 60034-30:2009 and EN 60034-30-1:2014.**
- Metric cable gland according to EN 50262.
- PTC included in motors from 30 to 55 kW (one per phase, 155°C).
- **Single-phase** version:
0,37 to 2,2 kW (2-pole)
220-240 V 50 Hz
Built-in automatic reset overload protection up to 1,5 kW. For higher powers the protection must be provided by the user.
Maximum ambient temperature: 40 °C.
- **Three-phase** version:
0,37 to 55 kW (2-pole)
220-240/380-415 V 50 Hz for power up to 3 kW.
380-415/660-690 V 50 Hz for power above 3 kW.
Overload protection to be provided by the user.
Maximum ambient temperature: 50 °C,
(40 °C, for model with power of 0,37 kW)

From 1 July 2021 in accordance with the **Regulations (EU) 2019/1781 and 2021/341**, the three-phase 50 Hz, 60 Hz or 50/60 Hz **surface motors** with **power outputs ranging from 0,12 to 0,749 kW** must have a minimum level **IE2** efficiency; the ones with power outputs ranging **from 0,75 and 1000 kW** must have a minimum level of **IE3** efficiency.

From 1 July 2023, it will be introduced additional requirements.

The following tables also contain the mandatory information pursuant to Annex I, section 2, of the aforementioned Regulations.

SINGLE-PHASE MOTORS AT 50 Hz, 2-POLE

P _N kW	MOTOR TYPE	IEC SIZE*	Construction Design	INPUT CURRENT		CAPACITOR		DATA FOR 230 V 50 Hz VOLTAGE						OPERATING CONDITIONS **		
				In (A)	220-240 V	μF	V	min ⁻¹	Is / In	η %	cosφ	Tn Nm	Ts/Tn	Tm/Tn	Altitude asl m	T. amb min/max °C
0,37	SM71RB14/104	71R	V18/B14	2,79-2,85	14	450	2745	2,64	65,1	0,96	1,39	0,68	1,63	≤ 1000	-15/40	No
0,55	SM71B14/105	71		3,76-3,99	16	450	2820	3,72	68,9	0,91	1,86	0,61	2,00			
0,75	SM80RB14/107	80R		4,90-4,85	20	450	2765	3,42	70,1	0,96	2,59	0,58	1,75			
1,1	SM80B14/111	80		6,88-6,65	30	450	2800	3,89	74,7	0,96	3,75	0,46	1,72			
1,5	SM90RB14/115	90R		9,21-8,58	40	450	2810	4,00	76,1	0,98	5,09	0,39	1,74			
2,2	PLM90B14/122	90		12,5-11,6	70	450	2825	4,47	82,4	0,97	7,43	0,53	1,87			

* R = Reduced size of motor casing as compared to shaft extension and flange.

1-22sv-motm_2p50-en_c_te

** Operating conditions related only to the motor. For the electric pump refer to the IOM.

e-SV SERIES

THREE-PHASE MOTORS AT 50 Hz, 2-POLE (up to 22 kW)

P _N kW	Manufacturer		IEC SIZE*	Construction Design	N. of Poles	f _N Hz	Data for 400 V / 50 Hz Voltage				
	Xylem Service Italia Srl Reg. No. 07520560967 Montecchio Maggiore Vicenza - Italia						cosφ	I _s / I _N	T _N Nm	T _s /T _N	T _m /T _N
	Model										
0,37	SM71RB14/304		71R	V18/B14	2	50	0,64	4,35	1,37	4,14	4,10
0,55	SM71B14/305		71				0,71	6,25	1,84	3,96	3,97
0,75	SM80B14/307 PE		80				0,78	7,38	2,48	3,57	3,75
1,1	SM80B14/311 PE		80				0,79	8,31	3,63	3,95	3,95
1,5	SM90RB14/315 PE		90R				0,80	8,80	4,96	4,31	4,10
2,2	PLM90B14/322 E3		90				0,80	8,77	7,28	3,72	3,70
3	PLM100RB14/330 E3		100R				0,79	7,81	9,93	4,26	3,94
4	PLM112RB14S6/340 E3		112R				0,85	9,13	13,2	3,82	4,32
5,5	PLM132RB5/355 E3		132R				0,85	10,5	18,1	4,74	5,11
7,5	PLM132B5/375 E3		132				0,85	10,2	24,4	3,43	4,76
11	PLM160RB5/3110 E3		160R				0,86	9,89	35,9	3,46	4,59
15	PLM160B5/3150 E3		160				0,88	9,51	48,6	2,73	4,32
18,5	PLM160B5/3185 E3		160				0,88	9,81	59,9	2,81	4,53
22	PLM180RB5/3220 E3		180R				0,85	10,9	71,1	3,26	5,12

P _N kW	Voltage U _N V											n _N min ⁻¹	Operating conditions **		
	Δ			Y			Δ			Y			Altitude Above Sea Level (m)	T. amb min/max °C	ATEX
	220 V	230 V	240 V	380 V	400 V	415 V	380 V	400 V	415 V	660 V	690 V				
	I _N (A)														
0,37	2,03	2,18	2,32	1,17	1,26	1,34	-	-	-	-	-	2745 ÷ 2800	≤ 1000	-15 / 40	No
0,55	2,46	2,49	2,56	1,42	1,44	1,48	-	-	-	-	-	2835 ÷ 2865			
0,75	2,96	2,94	2,96	1,71	1,70	1,71	1,70	1,69	1,70	0,98	0,98	2875 ÷ 2895			
1,1	4,19	4,14	4,16	2,42	2,39	2,40	2,41	2,38	2,38	1,39	1,37	2870 ÷ 2900			
1,5	5,56	5,49	5,51	3,21	3,17	3,18	3,21	3,18	3,19	1,85	1,84	2870 ÷ 2895			
2,2	7,97	7,90	7,98	4,6	4,56	4,61	4,57	4,54	4,57	2,64	2,62	2880 ÷ 2900			
3	11,0	11,0	11,2	6,35	6,33	6,44	6,29	6,27	6,34	3,63	3,62	2865 ÷ 2895			
4	13,6	13,4	13,4	7,87	7,75	7,74	7,80	7,62	7,61	4,50	4,40	2885 ÷ 2910			
5,5	18,1	17,9	18,1	10,4	10,4	10,4	10,6	10,5	10,7	6,10	6,05	2880 ÷ 2910			
7,5	24,8	24,4	24,3	14,3	14,1	14,0	14,4	14,1	14,2	8,32	8,16	2920 ÷ 2935			
11	35,7	35,0	34,9	20,6	20,2	20,2	20,6	20,2	20,2	11,9	11,7	2910 ÷ 2930			
15	47,6	46,1	45,2	27,5	26,6	26,1	27,5	26,6	26,1	15,9	15,3	2940 ÷ 2950			
18,5	58,3	56,7	55,6	33,7	32,7	32,1	34,0	33,0	32,7	19,6	19,0	2940 ÷ 2950			
22	72,9	73,1	73,7	42,1	42,2	42,6	40,9	40,4	40,6	23,6	23,3	2950 ÷ 2960			

P _N kW	Efficiency η _N %																		IE
	Δ 220 V			Δ 230 V			Δ 240 V			Δ 380 V			Δ 400 V			Δ 415 V			
	Y 380 V			Y 400 V			Y 415 V			Y 660 V			Y 690 V						
	4/4	3/4	2/4	4/4	3/4	2/4	4/4	3/4	2/4	4/4	3/4	2/4	4/4	3/4	2/4	4/4	3/4	2/4	
0,37	70,4	73,2	68,9	70,4	70,3	64,5	70,4	67,2	60,2	-	-	-	-	-	-	-	-	-	2
0,55	74,1	74,2	70,4	74,1	73,6	68,8	74,1	72,7	67,1	-	-	-	-	-	-	-	-	-	
0,75	82,5	83,1	81,3	82,8	82,7	80,1	82,6	82,0	78,9	82,5	82,0	78,9	82,5	82,0	78,9	82,5	82,0	78,9	
1,1	84,0	84,7	83,4	84,4	84,5	82,5	84,3	84,0	81,4	84,0	84,0	81,4	84,0	84,0	81,4	84,0	84,0	81,4	
1,5	85,6	86,5	85,8	85,9	86,4	84,9	86,0	86,0	84,0	85,6	86,0	84,0	85,6	86,0	84,0	85,6	86,0	84,0	
2,2	86,5	87,4	86,8	86,4	86,9	85,7	86,6	86,7	85,0	86,4	86,7	85,0	86,4	86,7	85,0	86,4	86,7	85,0	
3	87,2	88,5	88,3	87,5	88,2	87,5	87,5	87,8	86,4	87,2	87,8	86,4	87,2	87,8	86,4	87,2	87,8	86,4	
4	89,1	90,1	89,2	89,1	90,1	89,2	89,1	90,1	89,2	89,1	90,3	90,4	89,6	90,4	89,9	89,6	90,1	89,2	
5,5	89,5	89,6	88,0	89,5	89,6	88,0	89,5	89,6	88,0	89,5	90,3	89,9	89,7	90,0	89,0	89,6	89,6	88,0	
7,5	90,6	90,5	89,0	90,6	90,5	89,0	90,6	90,5	89,0	90,6	91,0	90,2	90,8	90,8	89,6	90,7	90,5	89,0	
11	91,3	92,0	91,1	91,3	92,0	91,1	91,3	92,0	91,1	91,3	92,2	92,2	91,6	92,2	91,7	91,7	92,0	91,1	
15	92,5	92,4	91,2	92,5	92,4	91,2	92,5	92,4	91,2	92,7	93,3	92,9	93,1	93,3	92,7	92,5	92,4	91,2	
18,5	92,6	93,1	92,4	92,6	93,1	92,4	92,6	93,1	92,4	92,6	93,2	93,0	92,9	93,3	92,8	92,9	93,1	92,4	
22	93,0	92,7	91,3	93,0	92,7	91,3	93,0	92,7	91,3	93,0	93,2	92,4	93,1	93,0	91,9	93,0	92,7	91,3	

* R = Reduced size of motor casing as compared to shaft extension and flange.

sv-IE3-mott22-2p50-en_c_te

** Operating conditions to be referred to motor only. About electric pump, refer to limits in user's manual.

e-SV SERIES

THREE-PHASE MOTORS AT 50 Hz, 2-POLE (from 30 to 55 kW)

P _N kW	Manufacturer	IEC SIZE	Construction Design	N. of Poles	f _N Hz	Data for 400 V / 50 Hz Voltage				
	Model					cosφ	I _s / I _N	T _N Nm	T _s /T _N	T _m /T _N
30	OMEGA MOTOR SANAYI A.S. Dudullu Organize Sanayi Bölgesi 2. Cadde No: 10 34775 Ümraniye ISTANBUL/TURKEY Reg. No. 913733	200	V1	2	50	0,89	7,80	96,90	2,60	3,10
37	3MAS 200LA2 V1 30KW E3	200				0,90	8,00	119,4	2,90	3,20
45	3MAS 225M2 V1 45KW E3	225				0,91	8,20	144,4	2,70	3,30
55	3MGS 250M2 V1 55KW E3	250				0,90	7,60	176,4	2,50	3,00

P _N kW	Voltage U _N V					n _N min ⁻¹	Operating conditions **		
	Δ			Y			Altitude Above Sea Level (m)	T. amb min/max °C	ATEX
	380 V	400 V	415 V	660 V	690 V				
	I _N (A)								
30	55,3	52,2	50,8	31,8	30,3	2965	≤ 1000	-20 / 50	No
37	66,6	63,9	61,5	38,4	37,0	2965			
45	80,6	75,9	73,7	46,4	44,0	2975			
55	98,2	92,7	89,7	56,5	53,7	2975			

P _N kW	Efficiency η _N %									IE
	Δ 380 V Y 660 V			Δ 400 V Y 690 V			Δ 415 V			
	4/4	3/4	2/4	4/4	3/4	2/4	4/4	3/4	2/4	
30	93,0	93,1	93,0	93,3	93,5	93,4	93,4	93,6	93,4	3
37	93,5	94,0	93,7	93,7	94,1	93,8	93,8	94,2	93,9	
45	93,8	94,0	93,5	94,0	94,2	93,6	94,2	94,4	93,8	
55	93,8	94,0	93,9	94,3	94,6	94,5	94,4	94,7	94,5	

** Operating conditions to be referred to motor only. About electric pump, refer to limits in user's manual.

sv-IE3-mott55-2p50-en_c_te

Note: Observe the regulations and codes locally in force regarding sorted waste disposal.

MOTOR NOISE 2-POLE MOTORS

POWER kW	MOTOR TYPE IEC SIZE*	NOISE LpA dB
0.37	71R	<70
0.55	71	<70
0.75	80-80R	<70
1.1	80	<70
1.5	90-90R	<70
2.2	90	<70
3	100R	<70
4	112R	<70
5.5	132R	<70
7.5	132	<70
11	160R	73
15	160	75
18.5	160	75
22	180R	75
30	200	71
37	200	71
45	225	73
55	250	75

*R = Reduced motor casing size with respect to shaft extension and related flange.

1-125sv_mott_2p50-en_d_tr

The tables below show the mean sound pressure levels (Lp) measured at 1 meter distance in a free field according to EN ISO 11203. The noise values are measured on 50 Hz motors and have a tolerance of 3 dB (A) according to EN ISO 4871.

AVAILABLE VOLTAGES

0.37 to 22 kW MOTORS FOR e-SV SERIES, 2-POLE

P _N kW	SINGLE-PHASE							
	50 Hz				60 Hz			
	1 x 220-240	1 x 100	1 x 110-120	1 x 220-230	1 x 100	1 x 110-115	1 x 120-127	1 x 200-210
0,37	s	o	o	s	-	o	-	-
0,55	s	o	o	s	o	o	o	o
0,75	s	o	o	s	o	o	o	o
1,1	s	-	o	s	-	o	-	o
1,5	s	-	-	s	-	o	-	o
2,2	s	-	-	s	-	-	-	-

P _N kW	THREE-PHASE																		
	50 Hz									60 Hz						50/60 Hz			
	3 x 220-230-240/380-400-415	3 x 380-400-415/660-690	3 x 200-208/346-360	3 x 255-265/440-460	3 x 290-300/500-525	3 x 440-460/-	3 x 500-525/-	3 x 220-230/380-400	3 x 255-265-277/440-460-480	3 x 380-400/660-690	3 x 440-460-480/-	3 x 110-115/190-200	3 x 200-208/346-360	3 x 330-346/575-600	3 x 575/-	3 x 230/400 50 Hz	3 x 265/460 60 Hz	3 x 400/690 50 Hz	3 x 460/- 60 Hz
0,37	s	o	o	o	o	o	o	s	o	o	o	o	o	o	o	o	o	o	o
0,55	s	o	o	o	o	o	o	s	o	o	o	o	o	o	o	o	o	o	o
0,75	s	o	o	o	o	o	o	s	o	o	o	o	o	o	o	o	o	o	o
1,1	s	o	o	o	o	o	o	s	o	o	o	o	o	o	o	o	o	o	o
1,5	s	o	o	o	o	o	o	s	o	o	o	o	o	o	o	o	o	o	o
2,2	s	o	o	o	o	o	o	s	o	o	o	o	o	o	o	o	o	o	o
3	s	o	o	o	o	o	o	s	o	o	o	o	o	o	o	o	o	o	o
4	o	s	o	o	o	o	o	s	o	o	o	o	o	o	o	o	o	o	o
5,5	o	s	o	o	o	o	o	s	o	o	o	o	o	o	o	o	o	o	o
7,5	o	s	o	o	o	o	o	s	o	o	o	o	o	o	o	o	o	o	o
11	o	s	o	o	o	o	o	s	o	o	o	o	o	o	o	o	o	o	o
15	o	s	o	o	o	o	o	s	o	o	o	o	o	o	o	o	o	o	o
18,5	o	s	o	o	o	o	o	s	o	o	o	o	o	o	o	o	o	o	o
22	o	s	o	o	o	o	o	s	o	o	o	o	o	o	o	o	o	o	o

s = Standard voltage o = voltage upon request - = Not available

sv-volt-low-a-en_b_te

Please contact the sales network to check other available voltages.

Tolerances on nominal voltages

- 50 Hz:

- ± 10% on the single voltage value shown on the rating plate.
- ± 5% on voltage range shown on the rating plate.

- 60 Hz:

- ± 10% on the voltage values shown on the rating plate.

e-SV SERIES PUMPS (ErP 2009/125/EC)

With the **Regulation (EU) N. 547/2012**, the European Commission has established the requirements of ecodesign for some typologies of pumps used for pumping clean water, placed on the market and operated as stand-alone units or as parts of other products.

For vertical multi-stage pumps (MS-V for the Regulations), the requirements refers to:

- just the pump and not the pump and motor assembly (electric or combustion);
- pumps with:
 - a nominal pressure PN not higher than 25 bar (2500 kPa);
 - a speed of 2900 min⁻¹ (for electric pumps this means 50 Hz 2-pole electric motors);
 - a maximum flow of 100 m³/h;
- use with clean water at a temperature ranging from -10°C to 120°C (the test is performed with cold water at a temperature not higher than 40°C).

This regulation states that water pumps shall have index MEI coming from a dedicated formula which considers hydraulic efficiency values at 'best efficiency point' (BEP), 75 % of the flow at BEP (Part load – PL) and 110 % of the flow at BEP (Over load – OL).

The Regulation also establishes the following deadline:

from	minimum efficiency index (MEI)
1 st January 2015	MEI ≥ 0,4

Regulation (EU) n. 547/2012 – Annex II – point 2 (Product information requirements)

- 1) Minimum efficiency index: see the MEI column in the tables in the *Hydraulic performance* section.
- 2) The benchmark for most efficient water pumps is MEI ≥ 0,70.
- 3) Year of manufacture: see date on rating plate (≥ 2013).
- 4) Manufacturer: Xylem Service Italia Srl - Reg. No 07520560967 - Montecchio Maggiore, Vicenza, Italy.
- 5) Product type: see the PUMP TYPE column in the tables in the *Hydraulic performance* section.
- 6) Hydraulic pump efficiency with trimmed impeller: not applicable to these products.
- 7) Pump performance curves, including the performance curve: see the *Operating Characteristics* graphs in the following pages.
- 8) The efficiency of a pump with a trimmed impeller is usually lower than that of a pump with the full impeller diameter. The trimming of the impeller will adapt the pump to a fixed duty point, leading to reduced energy consumption. The minimum efficiency index (MEI) is based on the full impeller diameter.
- 9) The operation of this water pump with variable duty points may be more efficient and economic when controlled, for example, by the use of a variable speed drive that matches the pump duty to the system.
- 10) Information relevant for disassembly, recycling or disposal at end-of-life: observe the current laws and by-laws governing sorted waste disposal. Consult the product operating manual.
- 11) "Designed for use below – 10 °C only": note not applicable to these products.
- 12) "Designed for use above 120 °C only": note not applicable to these products.
- 13) Specific instructions for pumps as per points 11 and 12: not applicable to these products.
- 14) "Information on benchmark efficiency is available at": www.europump.org (Ecodesign section).
- 15) The benchmark efficiency graphs with MEI = 0.7 and MEI = 0.4 are available at www.europump.org, (Ecodesign, Efficiency charts). Refer to "Multistage Vertical 2900 rpm"

e-SV SERIES

HYDRAULIC PERFORMANCE RANGE AT 50 Hz, 2 POLES

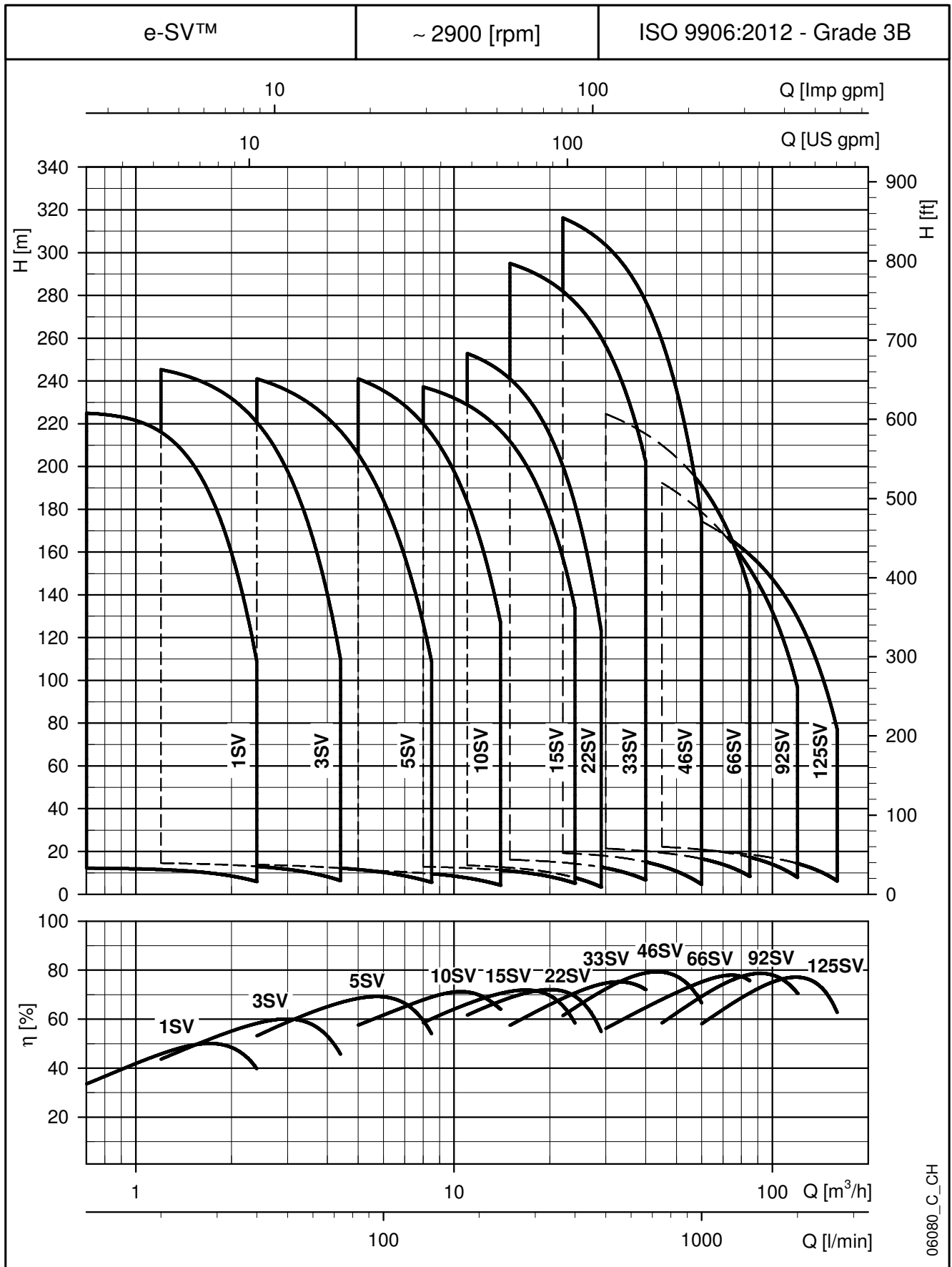

06080_C_CH

1, 3, 5SV SERIES HYDRAULIC PERFORMANCE TABLE AT 50 Hz, 2 POLES

PUMP TYPE	RATED POWER		MEI ≥ (1)	Q = DELIVERY													
	kW	HP		l/min 0	12	20	25	30	35	40	45	50	60	73	100	120	141
				m³/h 0	0,7	1,2	1,5	1,8	2,1	2,4	2,7	3,0	3,6	4,4	6,0	7,2	8,5
H = TOTAL HEAD IN METRES OF COLUMN OF WATER																	
1SV02	0,37	0,5	0,70	12,2	12,2	11,5	10,7	9,5	7,9	6,0							
1SV03	0,37	0,5	0,70	18,0	18,0	17,0	15,7	13,8	11,4	8,4							
1SV04	0,37	0,5	0,70	23,7	23,5	22,1	20,4	17,9	14,6	10,6							
1SV05	0,37	0,5	0,70	29,3	28,9	27,0	24,8	21,6	17,4	12,5							
1SV06	0,37	0,5	0,70	34,8	34,2	31,7	28,9	25,0	20,0	14,0							
1SV07	0,37	0,5	0,70	40,2	39,2	36,1	32,7	28,1	22,2	15,2							
1SV08	0,55	0,75	0,70	48,1	47,9	45,2	41,8	36,8	30,4	22,4							
1SV09	0,55	0,75	0,70	53,7	53,4	50,4	46,4	40,8	33,5	24,6							
1SV10	0,55	0,75	0,70	59,4	59,0	55,5	51,0	44,7	36,6	26,6							
1SV11	0,55	0,75	0,70	65,1	64,5	60,4	55,5	48,5	39,5	28,5							
1SV12	0,75	1	0,70	73,3	73,1	69,3	64,3	57,1	47,6	35,7							
1SV13	0,75	1	0,70	79,2	78,9	74,8	69,4	61,6	51,2	38,2							
1SV15	0,75	1	0,70	90,9	90,5	85,6	79,3	70,1	58,1	43,1							
1SV17	1,1	1,5	0,70	105,2	104,9	100,0	93,1	82,6	68,6	51,2							
1SV19	1,1	1,5	0,70	117,0	116,7	111,0	103,2	91,5	75,8	56,3							
1SV22	1,1	1,5	0,70	134,6	134,1	127,4	118,1	104,4	86,1	63,5							
1SV25	1,5	2	0,70	152,6	152,4	145,5	135,4	120,0	99,1	72,7							
1SV27	1,5	2	0,70	164,3	164,0	156,4	145,4	128,8	106,1	77,5							
1SV30	1,5	2	0,70	181,7	181,3	172,6	160,1	141,2	115,7	83,9							
1SV32	2,2	3	0,70	197,2	197,1	188,4	175,8	156,5	130,0	96,3							
1SV34	2,2	3	0,70	209,2	208,9	199,8	186,3	165,5	137,1	101,2							
1SV37	2,2	3	0,70	225,9	224,9	216,1	201,9	179,3	148,1	108,7							
3SV02	0,37	0,5	0,70	14,9		14,5	14,3	14,0	13,5	13,0	12,4	11,7	9,8	6,5			
3SV03	0,37	0,5	0,70	22,0		21,2	20,8	20,3	19,6	18,7	17,7	16,6	13,7	8,6			
3SV04	0,37	0,5	0,70	28,9		27,7	27,1	26,2	25,2	23,9	22,5	20,8	16,8	10,1			
3SV05	0,55	0,75	0,70	37,2		36,4	35,8	35,0	33,9	32,6	31,1	29,2	24,5	16,2			
3SV06	0,55	0,75	0,70	44,4		43,4	42,6	41,6	40,2	38,6	36,6	34,3	28,5	18,5			
3SV07	0,75	1	0,70	52,5		51,8	51,0	50,0	48,7	47,0	45,0	42,5	36,1	24,6			
3SV08	0,75	1	0,70	60,0		59,1	58,2	57,0	55,4	53,4	51,0	48,1	40,7	27,5			
3SV09	1,1	1,5	0,70	67,7		66,8	65,8	64,5	62,8	60,6	57,9	54,6	46,4	31,6			
3SV10	1,1	1,5	0,70	75,0		73,8	72,7	71,3	69,3	66,9	63,8	60,2	51,0	34,5			
3SV11	1,1	1,5	0,70	82,3		81,0	79,7	78,0	75,8	73,1	69,7	65,7	55,5	37,4			
3SV12	1,1	1,5	0,70	89,6		87,8	86,4	84,5	82,1	79,1	75,5	71,1	59,9	40,1			
3SV13	1,5	2	0,70	98,1		96,7	95,4	93,5	91,0	87,8	83,9	79,2	67,2	45,6			
3SV14	1,5	2	0,70	105,6		104,1	102,5	100,4	97,7	94,2	89,9	84,8	71,8	48,5			
3SV16	1,5	2	0,70	119,9		117,8	116,1	113,6	110,5	106,5	101,6	95,8	80,9	54,2			
3SV19	2,2	3	0,70	144,3		142,3	140,3	137,5	133,9	129,2	123,5	116,7	99,1	67,6			
3SV21	2,2	3	0,70	159,3		156,9	154,6	151,4	147,3	142,1	135,7	128,0	108,5	73,6			
3SV23	2,2	3	0,70	174,0		171,1	168,5	165,0	160,4	154,7	147,6	139,2	117,7	79,4			
3SV25	2,2	3	0,70	188,5		186,1	183,3	179,3	174,1	167,6	159,7	150,3	126,6	84,8			
3SV27	3	4	0,70	204,4		201,7	198,8	194,7	189,4	182,7	174,4	164,5	139,4	94,4			
3SV29	3	4	0,70	219,3		216,0	212,8	208,3	202,6	195,3	186,4	175,7	148,6	100,2			
3SV31	3	4	0,70	233,8		230,3	226,8	222,0	215,7	207,8	198,2	186,7	157,6	106,0			
3SV33	3	4	0,70	248,5		245,3	241,5	236,2	229,3	220,7	210,2	197,7	166,3	111,2			
5SV02	0,37	0,5	0,70	14,8						13,8	13,7	13,4	13,0	12,2	10,2	8,2	5,7
5SV03	0,55	0,75	0,70	22,8						21,8	21,6	21,3	20,7	19,7	16,9	14,1	10,3
5SV04	0,55	0,75	0,70	30,0						28,2	27,9	27,5	26,6	25,2	21,2	17,3	12,2
5SV05	0,75	1	0,70	38,0						36,4	36,0	35,5	34,5	32,9	28,2	23,5	17,1
5SV06	1,1	1,5	0,70	45,3						43,7	43,3	42,8	41,6	39,6	33,9	28,1	20,3
5SV07	1,1	1,5	0,70	52,7						50,7	50,1	49,5	48,1	45,8	39,1	32,2	23,1
5SV08	1,1	1,5	0,70	60,1						57,6	57,0	56,2	54,6	51,8	44,1	36,2	25,8
5SV09	1,5	2	0,70	68,0						65,5	64,8	64,0	62,2	59,3	50,6	41,9	30,2
5SV10	1,5	2	0,70	75,5						72,4	71,7	70,8	68,7	65,4	55,7	46,0	33,0
5SV11	1,5	2	0,70	82,8						79,3	78,4	77,5	75,2	71,4	60,7	49,9	35,6
5SV12	2,2	3	0,70	90,8						88,0	87,0	86,0	83,4	79,3	67,4	55,7	40,5
5SV13	2,2	3	0,70	98,3						95,0	94,0	92,8	90,0	85,5	72,6	59,9	43,5
5SV14	2,2	3	0,70	105,7						102,0	100,9	99,6	96,6	91,7	77,8	64,0	46,3
5SV15	2,2	3	0,70	113,1						109,0	107,8	106,4	103,1	97,8	82,8	68,1	49,1
5SV16	2,2	3	0,70	120,5						115,9	114,6	113,1	109,6	103,9	87,8	72,1	51,8
5SV18	3	4	0,70	135,8						131,1	129,7	128,0	124,1	117,8	99,9	82,3	59,5
5SV21	3	4	0,70	157,9						152,0	150,3	148,3	143,6	136,1	114,9	94,2	67,6
5SV23	4	5,5	0,70	174,4						168,9	167,2	165,1	160,2	152,3	129,6	107,2	78,2
5SV25	4	5,5	0,70	189,2						183,1	181,1	178,9	173,5	164,8	140,1	115,7	84,1
5SV28	4	5,5	0,70	211,5						204,2	201,9	199,4	193,3	183,4	155,5	128,0	92,7
5SV30	5,5	7,5	0,70	227,0						219,8	217,5	214,8	208,4	198,1	168,5	139,3	101,5
5SV33	5,5	7,5	0,70	249,2						241,0	238,4	235,5	228,4	216,9	184,2	151,9	110,3

Hydraulic performances in compliance with ISO 9906:2012 - Grade 3B (ex ISO 9906:1999 - Annex A)

1-5sv-2p50-en_e_th

10, 15, 22SV SERIES

HYDRAULIC PERFORMANCE TABLE AT 50 Hz, 2 POLES

PUMP TYPE	RATED POWER		MEI ≥ (1)	Q = DELIVERY													
	kW	HP		l/min 0	83,34	100	133	170	183,34	233	270	330	350	400	430	460	483,33
				m ³ /h 0	5,0	6,0	8,0	10,2	11,0	14,0	16,2	19,8	21,0	24,0	25,8	27,6	29,0
H = TOTAL HEAD IN METRES OF COLUMN OF WATER																	
10SV01	0,75	1	0,70	11,8	11,2	10,9	9,9	8,3	7,6	4,3							
10SV02	0,75	1	0,70	23,6	21,9	21,3	19,6	17,0	15,8	10,0							
10SV03	1,1	1,5	0,70	35,7	33,0	32,1	29,6	25,8	24,1	16,0							
10SV04	1,5	2	0,70	47,7	44,2	43,0	39,9	34,8	32,6	21,7							
10SV05	2,2	3	0,70	60,0	56,1	54,7	50,9	44,9	42,2	29,0							
10SV06	2,2	3	0,70	71,8	66,8	65,0	60,4	53,1	49,8	33,9							
10SV07	3	4	0,70	83,6	78,3	76,2	70,8	62,1	58,3	39,8							
10SV08	3	4	0,70	95,3	88,9	86,5	80,1	70,2	65,7	44,5							
10SV09	4	5,5	0,70	106,3	100,1	97,5	90,8	80,0	75,1	52,1							
10SV10	4	5,5	0,70	118,0	110,8	107,9	100,3	88,2	82,8	57,2							
10SV11	4	5,5	0,70	129,6	121,3	118,1	109,6	96,3	90,3	62,1							
10SV13	5,5	7,5	0,70	156,0	146,5	142,7	132,6	116,4	109,2	74,3							
10SV15	5,5	7,5	0,70	179,5	167,9	163,4	151,6	132,8	124,3	83,9							
10SV17	7,5	10	0,70	205,0	193,2	188,5	175,7	154,7	145,2	98,8							
10SV18	7,5	10	0,70	216,9	204,2	199,1	185,5	163,2	153,1	104,0							
10SV20	7,5	10	0,70	240,6	226,0	220,3	205,0	180,2	168,9	114,3							
10SV21	11	15	0,70	253,6	241,0	235,5	220,2	195,0	183,5	127,5							
15SV01	1,1	1,5	0,70	14,0			12,9	12,4	12,2	11,3	10,4	8,4	7,6	5,1			
15SV02	2,2	3	0,70	28,7			26,7	25,9	25,5	23,9	22,4	18,9	17,4	13,1			
15SV03	3	4	0,70	43,3			40,4	39,1	38,6	36,2	33,8	28,7	26,5	20,1			
15SV04	4	5,5	0,70	58,4			54,7	53,1	52,5	49,4	46,3	39,7	36,9	28,7			
15SV05	4	5,5	0,70	72,7			67,8	65,8	65,0	61,0	57,1	48,7	45,2	34,9			
15SV06	5,5	7,5	0,70	87,6			81,5	79,4	78,4	74,1	69,9	60,3	56,3	44,2			
15SV07	5,5	7,5	0,70	101,9			94,5	91,9	90,8	85,7	80,6	69,4	64,7	50,5			
15SV08	7,5	10	0,70	117,4			110,9	108,0	106,8	100,8	94,9	82,0	76,7	60,6			
15SV09	7,5	10	0,70	131,9			124,4	121,0	119,6	112,8	106,1	91,5	85,5	67,4			
15SV10	11	15	0,70	147,7			138,8	135,3	133,8	126,7	119,6	103,9	97,4	77,5			
15SV11	11	15	0,70	162,3			152,4	148,5	146,8	138,9	131,1	113,8	106,5	84,7			
15SV13	11	15	0,70	191,3			179,2	174,5	172,5	163,1	153,7	133,1	124,5	98,6			
15SV15	15	20	0,70	222,1			209,9	204,8	202,6	192,2	181,7	158,3	148,5	118,8			
15SV17	15	20	0,70	251,6			237,3	231,4	228,9	216,9	205,0	178,4	167,3	133,6			
22SV01	1,1	1,5	0,70	14,7					13,5	12,7	12,0	10,4	9,7	7,7	6,3	4,7	3,4
22SV02	2,2	3	0,70	30,4					28,4	27,2	26,0	23,3	22,2	18,9	16,6	13,8	11,5
22SV03	3	4	0,70	45,4					42,2	40,4	38,5	34,5	32,8	27,8	24,2	20,2	16,6
22SV04	4	5,5	0,70	60,9					56,8	54,4	51,9	46,6	44,4	37,9	33,1	27,7	23,0
22SV05	5,5	7,5	0,70	76,0					70,9	67,9	64,9	58,3	55,6	47,4	41,4	34,7	28,8
22SV06	7,5	10	0,70	93,2					88,8	85,7	82,5	75,4	72,4	63,3	56,7	49,1	42,6
22SV07	7,5	10	0,70	108,5					103,1	99,4	95,7	87,2	83,7	73,1	65,3	56,5	48,8
22SV08	11	15	0,70	124,6					119,2	115,2	111,0	101,6	97,7	85,7	77,0	66,9	58,2
22SV09	11	15	0,70	140,1					133,7	129,2	124,4	113,8	109,3	95,8	86,0	74,6	64,8
22SV10	11	15	0,70	155,4					148,2	143,1	137,8	125,9	120,9	105,8	94,8	82,3	71,3
22SV12	15	20	0,70	186,1					178,6	172,9	166,8	152,9	147,0	129,1	115,9	100,7	87,4
22SV14	15	20	0,70	216,6					207,7	200,9	193,7	177,4	170,4	149,4	133,9	116,1	100,6
22SV17	18,5	25	0,70	263,5					252,8	244,7	236,0	216,2	207,8	182,3	163,6	142,0	123,2

Hydraulic performances in compliance with ISO 9906:2012 - Grade 3B (ex ISO 9906:1999 - Annex A)

10-22sv-2p50-en_d_th

33, 46SV SERIES

HYDRAULIC PERFORMANCE TABLE AT 50 Hz, 2 POLES

PUMP TYPE	RATED POWER		MEI ≥ (1)	Q = DELIVERY										
				Q = DELIVERY	250	300	367	417	500	583	667	750	900	1000
	kw	HP		l/min 0	15	18	22	25	30	35	40	45	54	60
33SV1/1A	2,2	3	0,70	17,4	16,2	15,7	15	14	12,2	9,8	6,7			
33SV1	3	4	0,70	23,8	21,7	21,2	20	20	17,8	15,5	12,7			
33SV2/2A	4	5,5	0,70	35,1	34,1	33,3	32	30	27	22,4	16,6			
33SV2/1A	4	5,5	0,70	40,8	38,8	37,9	36	35	32	27,5	22,3			
33SV2	5,5	7,5	0,70	47,8	45	44,1	43	41	39	35	29,9			
33SV3/2A	5,5	7,5	0,70	57,7	55,2	53,8	51	49	44	38	29,6			
33SV3/1A	7,5	10	0,70	64,5	61,3	60	58	56	51	45	37			
33SV3	7,5	10	0,70	71,5	67,4	66,0	64	62	58	52,0	44,6			
33SV4/2A	7,5	10	0,70	82	78,8	77	74	72	66	58	47,2			
33SV4/1A	11	15	0,70	88,9	85	83	81	78	73	65	55,1			
33SV4	11	15	0,70	95,9	91,1	90	87	85	80	73	63,1			
33SV5/2A	11	15	0,70	106	101,6	100	96	93	85	76	63			
33SV5/1A	11	15	0,70	112,7	107,2	105	102	99	92	82	70			
33SV5	15	20	0,70	120,4	114,9	113	110	107	101	92	80,5			
33SV6/2A	15	20	0,70	131,2	126,9	125	120	116	108	96	81,2			
33SV6/1A	15	20	0,70	139,1	133,5	131	128	124	116	105	90,4			
33SV6	15	20	0,70	145,6	139	137	133	129	121	110	96,1			
33SV7/2A	15	20	0,70	156	149,9	147	143	138	128	115	98,2			
33SV7/1A	18,5	25	0,70	163,3	156,6	154	150	145	136	123	106,2			
33SV7	18,5	25	0,70	170,3	162,8	160	156	152	142	130	113,3			
33SV8/2A	18,5	25	0,70	180,6	173,7	171	166	161	150	135	115,3			
33SV8/1A	18,5	25	0,70	187,4	179,5	177	171	166	156	141	121,7			
33SV8	22	30	0,70	194,1	185,1	182	177	172	161	147	128			
33SV9/2A	22	30	0,70	202,1	194,1	191	185	179	166	150	127,9			
33SV9/1A	22	30	0,70	210,2	201,2	198	192	186	174	157	135,9			
33SV9	22	30	0,70	216,8	206,8	204	198	193	181	165	143,7			
33SV10/2A	22	30	0,70	226,4	217,2	213	207	200	186	168	143,9			
33SV10/1A	30	40	0,70	234,5	225	221	215	209	196	178	154,2			
33SV10	30	40	0,70	241,8	231,3	228	222	216	203	185	162,2			
33SV11/2A	30	40	0,70	252	244	240	233	226	211	190	163,7			
33SV11/1A	30	40	0,70	259	249,2	245	238	232	217	197	171			
33SV11	30	40	0,70	265,7	253,6	250	243	236	222	203	176,9			
33SV12/2A	30	40	0,70	275,9	266,2	262	254	246	229	207	178,3			
33SV12/1A	30	40	0,70	282,8	271,5	267	260	252	236	214	185,6			
33SV12	30	40	0,70	289,8	276,7	272	265	258	242	221	192,9			
33SV13/2A	30	40	0,70	300,5	291,1	286	278	270	252	228	197,6			
33SV13/1A	30	40	0,70	306,9	294,9	290	282	274	256	233	202,4			
46SV1/1A	3	4	0,70	19,5			19,2	18,8	17,9	16,7	15,1	13,1	8,5	4,6
46SV1	4	5,5	0,70	27,2			24	23,5	22,5	21,4	19,9	18,2	14,3	10,8
46SV2/2A	5,5	7,5	0,70	38,8			39,8	39,2	37,8	35,7	32,9	29,4	21,1	13,9
46SV2	7,5	10	0,70	52,6			48,5	47,7	46,1	44,2	41,7	38,7	31,4	25,1
46SV3/2A	11	15	0,70	64,7			65,1	64	62	60	56	52	40,4	30,8
46SV3	11	15	0,70	80,8			74,3	73	71	68	65	60	50	40,7
46SV4/2A	15	20	0,70	92,4			90,7	90	87	83	79	73	58	45,6
46SV4	15	20	0,70	107,3			99,8	98	96	92	87	82	68	55,9
46SV5/2A	18,5	25	0,70	117,2			114,8	113	110	106	100	93	75	60,2
46SV5	18,5	25	0,70	134,5			125,1	123	120	116	110	103	86	71,5
46SV6/2A	22	30	0,70	143,7			139,3	138	134	129	122	113	92	73,4
46SV6	22	30	0,70	161			149,9	148	144	139	132	124	104	86
46SV7/2A	30	40	0,70	171,3			164,9	163	158	152	144	134	110	88,6
46SV7	30	40	0,70	188,6			175,5	173	168	162	155	145	122	101,2
46SV8/2A	30	40	0,70	198,2			190	188	182	176	166	155	127	103,1
46SV8	30	40	0,70	213,1			198,6	196	191	184	175	164	137	112,6
46SV9/2A	30	40	0,70	224,8			214,5	212	206	198	187	174	143	116
46SV9	37	50	0,70	240,9			225,2	222	217	209	199	187	157	130,2
46SV10/2A	37	50	0,70	252,7			241,1	238	232	223	212	198	164	133,9
46SV10	37	50	0,70	267,6			250,3	247	241	232	221	208	174	144,8
46SV11/2A	45	60	0,70	280,4			267,4	264	258	249	237	222	184	151,1
46SV11	45	60	0,70	295,5			276,4	273	266	257	245	230	194	161,3
46SV12/2A	45	60	0,70	307,3			292,5	289	282	272	259	243	202	165,8
46SV12	45	60	0,70	321,8			301	297	290	280	267	250	210	175
46SV13/2A	45	60	0,70	332,5			316,2	312	304	292	277	259	214	175

Hydraulic performances in compliance with ISO 9906:2012 - Grade 3B (ex ISO 9906:1999 - Annex A)

33-46sv-2p50-en_c_th

66, 92SV SERIES HYDRAULIC PERFORMANCE TABLE AT 50 Hz, 2 POLES

PUMP TYPE	RATED POWER		MEI ≥ (1)	Q = DELIVERY												
	kW	HP		l/min 0	500	600	700	750	900	1000	1200	1300	1417	1600	1800	2000
				m ³ /h 0	30	36	42	45	54	60	72	78	85	96	108	120
H = TOTAL HEAD METRES COLUMN OF WATER																
66SV1/1A	4	5,5	0,70	23,8	21,4	20,7	19,9	19,4	17,8	16,6	13,3	11,2	8,3			
66SV1	5,5	7,5	0,70	29,2	25,8	24,8	23,8	23,3	21,8	20,7	17,9	16,1	13,5			
66SV2/2A	7,5	10	0,70	47,5	42,6	41,2	39,5	38,6	36	32,9	26,4	22,2	16,4			
66SV2/1A	11	15	0,70	54,2	49,6	48,2	46,7	45,8	42,9	40,6	34,8	31,2	26,2			
66SV2	11	15	0,70	60,4	55,7	54,4	52,8	52	49,3	47,1	42	38,9	34,7			
66SV3/2A	15	20	0,70	78,4	71,6	70	67	66	62	58	49	43,3	35,3			
66SV3/1A	15	20	0,70	84,7	77,8	76	74	72	68	65	56	51	44,0			
66SV3	18,5	25	0,70	91,4	84,7	83	81	79	75	72	64	60	53,5			
66SV4/2A	18,5	25	0,70	108,9	99,6	97	94	92	86	82	70	63	52,8			
66SV4/1A	22	30	0,70	115,2	105,9	103	100	99	93	89	78	71	61,8			
66SV4	22	30	0,70	121,6	112,5	110	107	105	100	96	86	79	70,8			
66SV5/2A	30	40	0,70	139,1	127,5	124	120	118	111	106	92	83	70,4			
66SV5/1A	30	40	0,70	145,6	134	131	127	125	118	112	99	91	79,5			
66SV5	30	40	0,70	152	140,4	137	133	131	125	119	107	99	88,5			
66SV6/2A	30	40	0,70	169,5	155,6	152	147	144	136	129	113	103	88,1			
66SV6/1A	30	40	0,70	176	162	158	153	151	143	136	121	111	97,2			
66SV6	37	50	0,70	182,4	168,5	164	160	158	150	143	128	119	106,2			
66SV7/2A	37	50	0,70	199,9	183,7	179	174	171	161	153	134	122	105,8			
66SV7/1A	37	50	0,70	206,4	190,1	185	180	177	168	160	142	131	114,9			
66SV7	45	60	0,70	212,8	196,5	192	187	184	174	167	150	139	123,9			
66SV8/2A	45	60	0,70	230,3	211,8	206	200	197	186	177	156	142	123,5			
66SV8/1A	45	60	0,70	236,8	218,2	213	207	204	193	184	163	150	132,6			
66SV8	45	60	0,70	243,2	224,6	219	213	210	199	191	171	159	141,6			
92SV1/1A	5,5	7,5	0,60	24,5				22,2	21,5	20,9	19,4	18,5	17,3	15	11,8	7,9
92SV1	7,5	10	0,60	33,5				28,7	27,2	26,2	24,3	23,3	22,2	20,2	17,6	14,3
92SV2/2A	11	15	0,60	49,4				45,1	43,7	42,5	39,6	37,9	35,5	30,9	24,6	16,8
92SV2	15	20	0,60	67,8				58,2	55	53	49,5	47,6	45,2	41,4	36,3	29,6
92SV3/2A	18,5	25	0,60	82,4				74,4	72	70	65	62	59	52	43,6	32,9
92SV3	22	30	0,60	102,2				88,2	84	81	76	73	69	63	56	46,3
92SV4/2A	30	40	0,60	115,7				104	100	97	90	87	82	74	63	49
92SV4	30	40	0,60	133,1				117	112	108	101	97	92	85	75	62,5
92SV5/2A	37	50	0,60	149				133,2	128	124	116	111	105	95	81	64,6
92SV5	37	50	0,60	166,4				146,3	140	135	126	121	115	106	94	78,1
92SV6/2A	45	60	0,60	183,3				163,1	156	152	141	135	129	117	101	81
92SV6	45	60	0,60	200,9				175,9	168	163	151	146	139	127	113	94,2
92SV7/2A	45	60	0,60	216,8				192,4	184	179	167	160	152	138	120	96,7

Hydraulic performances in compliance with ISO 9906:2012 - Grade 3B (ex ISO 9906:1999 - Annex A)

66-92sv-2p50-en_c_th

125SV SERIES

HYDRAULIC PERFORMANCE TABLE AT 50 Hz, 2 POLES

PUMP TYPE	RATED POWER		MEI ≥	Q = DELIVERY													
				l/min 0	500	600	750	900	1000	1200	1416	1700	1900	2000	2150	2300	2666
	kW	HP		m ³ /h 0	30,0	36,0	45,0	54,0	60,0	72,0	85,0	102,0	114,0	120,0	129,0	138,0	160,0
H = TOTAL HEAD IN METRES OF COLUMN OF WATER																	
125SV1	7,5	10	-	27,6					20,8	19,8	18,6	16,8	15,3	14,4	12,9	11,3	6,2
125SV2	15	20	-	53,8					44,4	42,5	40,4	37,1	34,4	32,9	30,4	27,7	19,6
125SV3	22	30	-	80,7					66,5	63,8	60,6	55,7	51,6	49,4	45,7	41,5	29,4
125SV4	30	40	-	107,6					88,7	85,0	80,7	74,2	68,8	65,8	60,9	55,4	39,2
125SV5	37	50	-	134,5					110,9	106,3	100,9	92,8	86,0	82,3	76,1	69,2	49,0
125SV6	45	60	-	161,4					133,1	127,6	121,1	111,3	103,2	98,7	91,3	83,1	58,8
125SV7	55	75	-	188,3					155,2	148,8	141,3	129,9	120,4	115,2	106,6	96,9	68,6
125SV8/2A	55	75	-	211,5					174,4	167,2	158,7	145,9	135,3	129,4	119,7	108,9	77,1

Hydraulic performances in compliance with ISO 9906:2012 - Grade 3B (ex ISO 9906:1999 - Annex A)

125sv-2p50-en_b_th

1SV SERIES, 2 TO 15 STAGES DIMENSIONS AND WEIGHTS AT 50 Hz, 2 POLES

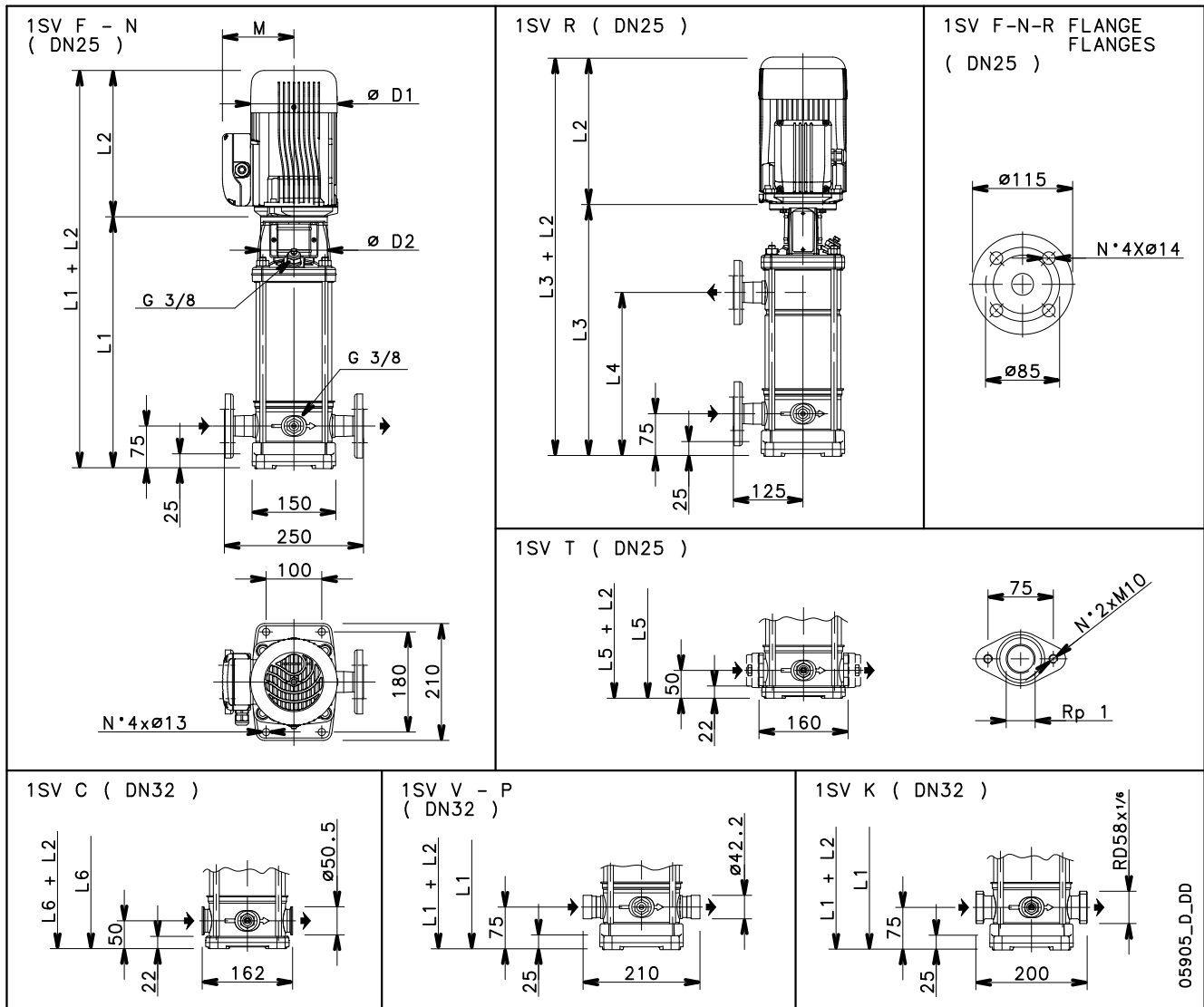

PUMP TYPE	MOTOR		DIMENSIONS (mm)												WEIGHT kg	
	kW	SIZE	L1	L2		L3	L4	L5	L6	M		D1		D2	PUMP	ELECTRIC
1SV02..	0,37	71	278	209	209	-	-	253	253	111	111	120	120	105	8,3	13
1SV03..	0,37	71	278	209	209	-	-	253	253	111	111	120	120	105	8,6	13,4
1SV04..	0,37	71	298	209	209	-	-	273	273	111	111	120	120	105	9	13,8
1SV05..	0,37	71	318	209	209	-	-	293	293	111	111	120	120	105	9,4	14,2
1SV06..	0,37	71	338	209	209	-	-	313	313	111	111	120	120	105	9,8	14,6
1SV07..	0,37	71	358	209	209	358	207	333	333	111	111	120	120	105	10,2	14,9
1SV08..	0,55	71	378	231	231	378	227	353	353	121	121	140	140	105	10,5	15,2
1SV09..	0,55	71	398	231	231	398	247	373	373	121	121	140	140	105	10,9	15,6
1SV10..	0,55	71	418	231	231	418	267	393	393	121	121	140	140	105	11,3	16
1SV11..	0,55	71	438	231	231	438	287	413	413	121	121	140	140	105	11,7	16,4
1SV12../D	0,75	80	468	226	263	468	307	443	443	121	129	140	155	120	12,7	22,3
1SV13../D	0,75	80	488	226	263	488	327	463	463	121	129	140	155	120	13,1	22,7
1SV15../D	0,75	80	528	226	263	528	367	503	503	121	129	140	155	120	13,9	23,5

1SV SERIES, 2 TO 15 STAGES

OPERATING CHARACTERISTICS AT 50 Hz, 2 POLES

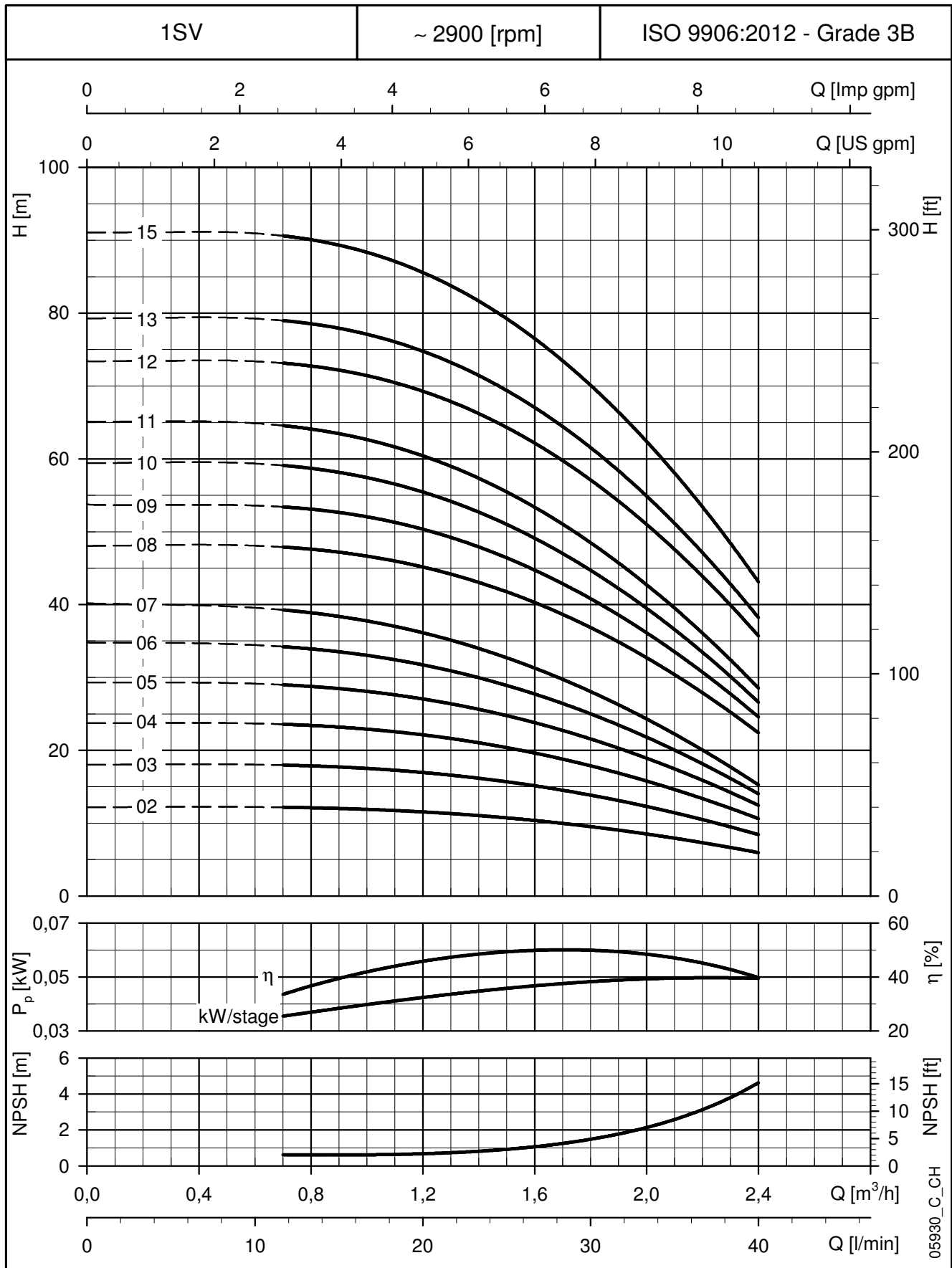

These performances are valid for liquids with density $\rho = 1.0 \text{ Kg/dm}^3$ and kinematic viscosity $\nu = 1 \text{ mm}^2/\text{sec}$.

1SV SERIES, 17 TO 37 STAGES DIMENSIONS AND WEIGHTS AT 50 Hz, 2 POLES

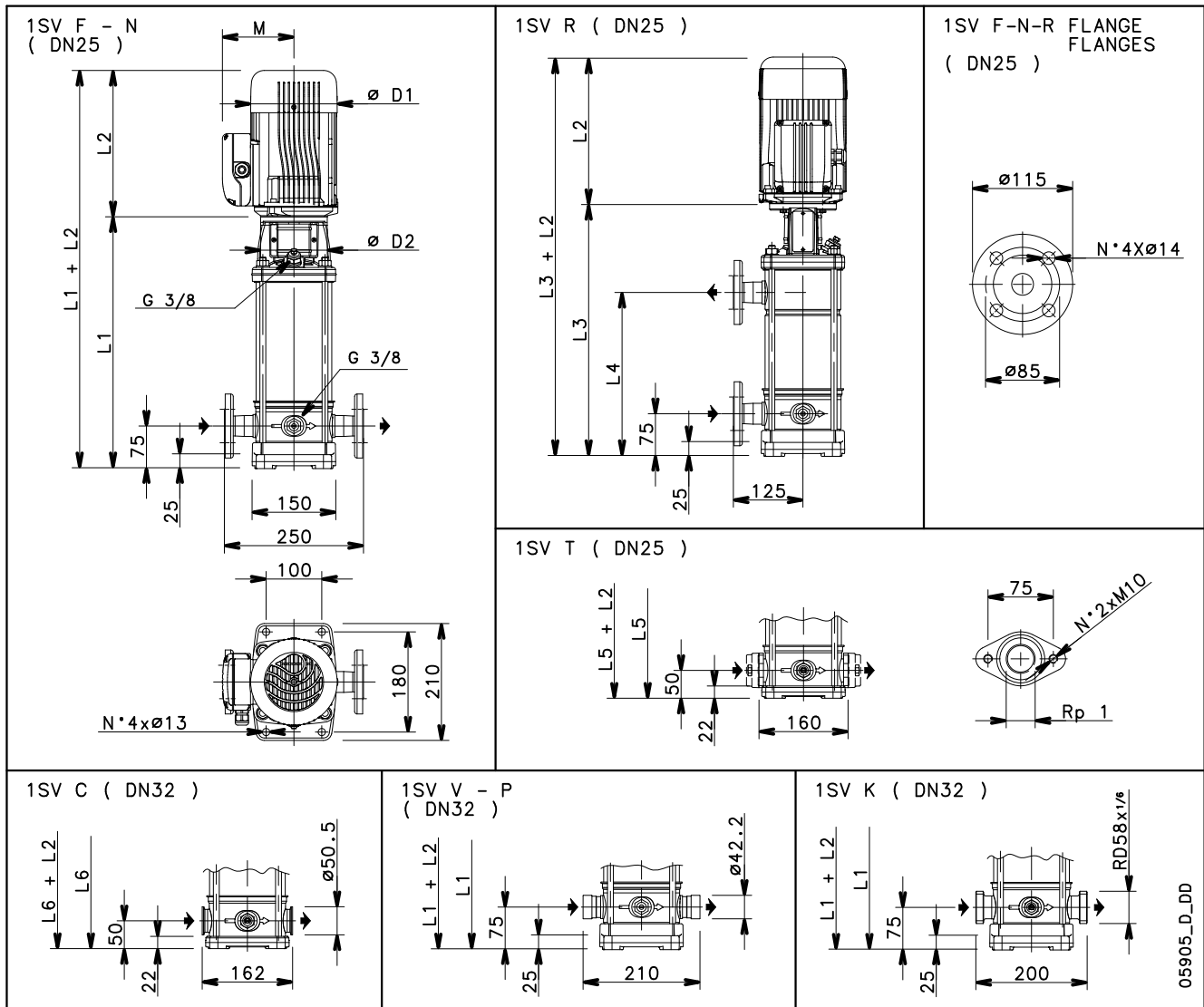

PUMP TYPE	MOTOR		DIMENSIONS (mm)												WEIGHT kg	
	kW	SIZE	L1	L2		L3	L4	L5	L6	M		D1		D2	PUMP	ELECTRIC
1SV17../D	1,1	80	568	263	263	568	407	543	543	137	129	155	155	120	14,7	26,6
1SV19../D	1,1	80	608	263	263	608	447	583	583	137	129	155	155	120	15,5	28
1SV22../D	1,1	80	668	263	263	668	507	643	643	137	129	155	155	120	16,7	28,6
1SV25../D	1,5	90	738	263	263	738	567	713	713	137	129	155	155	140	18,7	32
1SV27../D	1,5	90	778	263	263	778	607	-	753	137	129	155	155	140	19,5	33
1SV30../D	1,5	90	838	263	263	838	667	-	813	137	129	155	155	140	20,7	34
1SV32../D	2,2	90	878	298	298	878	707	-	853	151	134	174	174	140	21,5	37,8
1SV34../D	2,2	90	918	298	298	918	747	-	893	151	134	174	174	140	22,3	38,6
1SV37../D	2,2	90	978	298	298	978	807	-	953	151	134	174	174	140	23,5	39,8

1SV SERIES, 17 TO 37 STAGES
OPERATING CHARACTERISTICS AT 50 Hz, 2 POLES

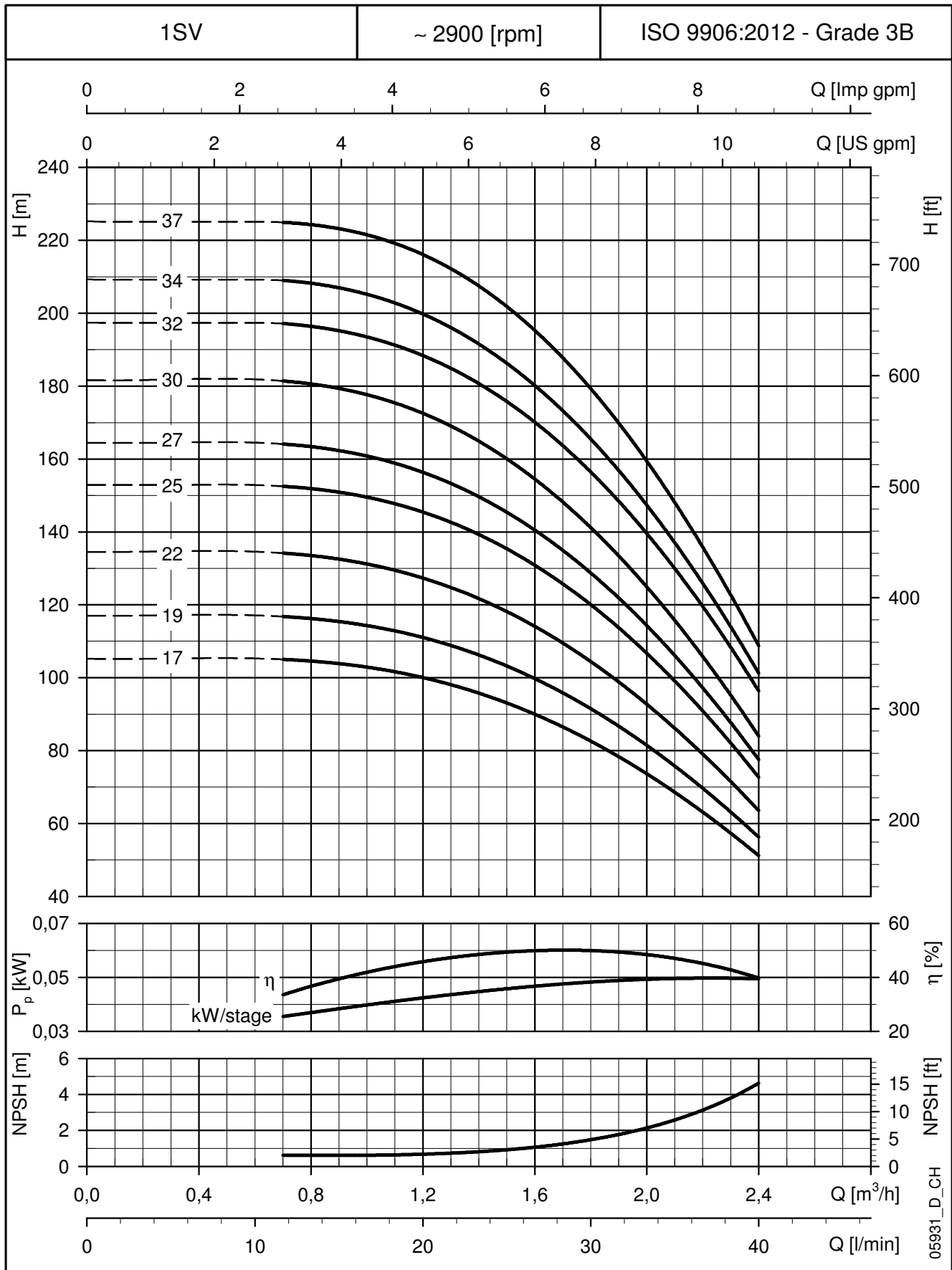

These performances are valid for liquids with density $\rho = 1.0 \text{ Kg/dm}^3$ and kinematic viscosity $\nu = 1 \text{ mm}^2/\text{sec}$.

3SV SERIES DIMENSIONS AND WEIGHTS AT 50 Hz, 2 POLES

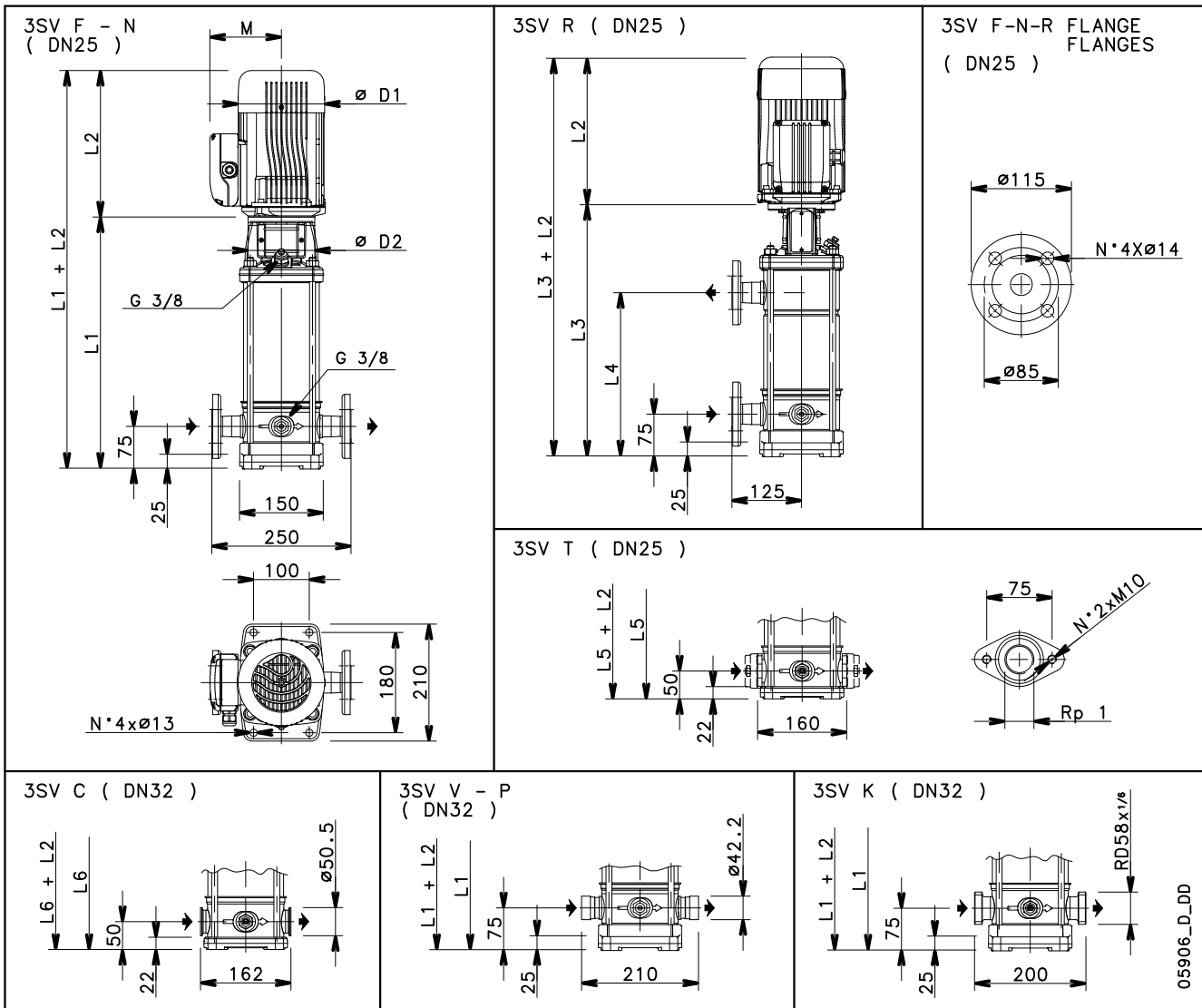

05906_D_DD

PUMP TYPE	MOTOR		DIMENSIONS (mm)											WEIGHT kg		
	kw	SIZE	L1	L2		L3	L4	L5	L6	M		D1		D2	PUMP	ELECTRIC
				1 ~	3 ~					1 ~	3 ~	1 ~	3 ~			
3SV02..	0,37	71	278	209	209	-	-	253	253	111	111	120	120	105	8	12,8
3SV03..	0,37	71	278	209	209	-	-	253	253	111	111	120	120	105	8,4	13,2
3SV04..	0,37	71	298	209	209	-	-	273	273	111	111	120	120	105	8,8	13,6
3SV05..	0,55	71	318	231	231	-	-	293	293	121	121	140	140	105	9,2	14
3SV06..	0,55	71	338	231	231	-	-	313	313	121	121	140	140	105	9,7	16,4
3SV07../D	0,75	80	368	226	263	368	207	343	343	121	129	140	155	120	10,9	20,5
3SV08../D	0,75	80	388	226	263	388	227	363	363	121	129	140	155	120	11,3	20,9
3SV09../D	1,1	80	408	263	263	408	247	383	383	137	129	155	155	120	11,7	23,1
3SV10../D	1,1	80	428	263	263	428	267	403	403	137	129	155	155	120	12,1	23,5
3SV11../D	1,1	80	448	263	263	448	287	423	423	137	129	155	155	120	12,5	23,9
3SV12../D	1,1	80	468	263	263	468	307	443	443	137	129	155	155	120	13,3	24,7
3SV13../D	1,5	90	498	263	263	498	327	473	473	137	129	155	155	140	14	27
3SV14../D	1,5	90	518	263	263	518	347	493	493	137	129	155	155	140	14,4	27,5
3SV16../D	1,5	90	558	263	263	558	387	533	533	137	129	155	155	140	15,2	28,2
3SV19../D	2,2	90	618	298	298	618	447	593	593	151	134	174	174	140	16,4	34,4
3SV21../D	2,2	90	658	298	298	658	487	633	633	151	134	174	174	140	17,2	35,2
3SV23../D	2,2	90	698	298	298	698	527	-	673	151	134	174	174	140	18	36
3SV25../D	2,2	90	738	298	298	738	567	-	713	151	134	174	174	140	18,9	36,8
3SV27../D	3	100	788	-	298	788	607	-	763	-	134	-	174	160	20,7	42,6
3SV29../D	3	100	828	-	298	828	647	-	803	-	134	-	174	160	21,5	43,4
3SV31../D	3	100	868	-	298	868	687	-	843	-	134	-	174	160	22,3	44,2
3SV33../D	3	100	908	-	298	908	727	-	883	-	134	-	174	160	23,1	45

3SV SERIES

OPERATING CHARACTERISTICS AT 50 Hz, 2 POLES

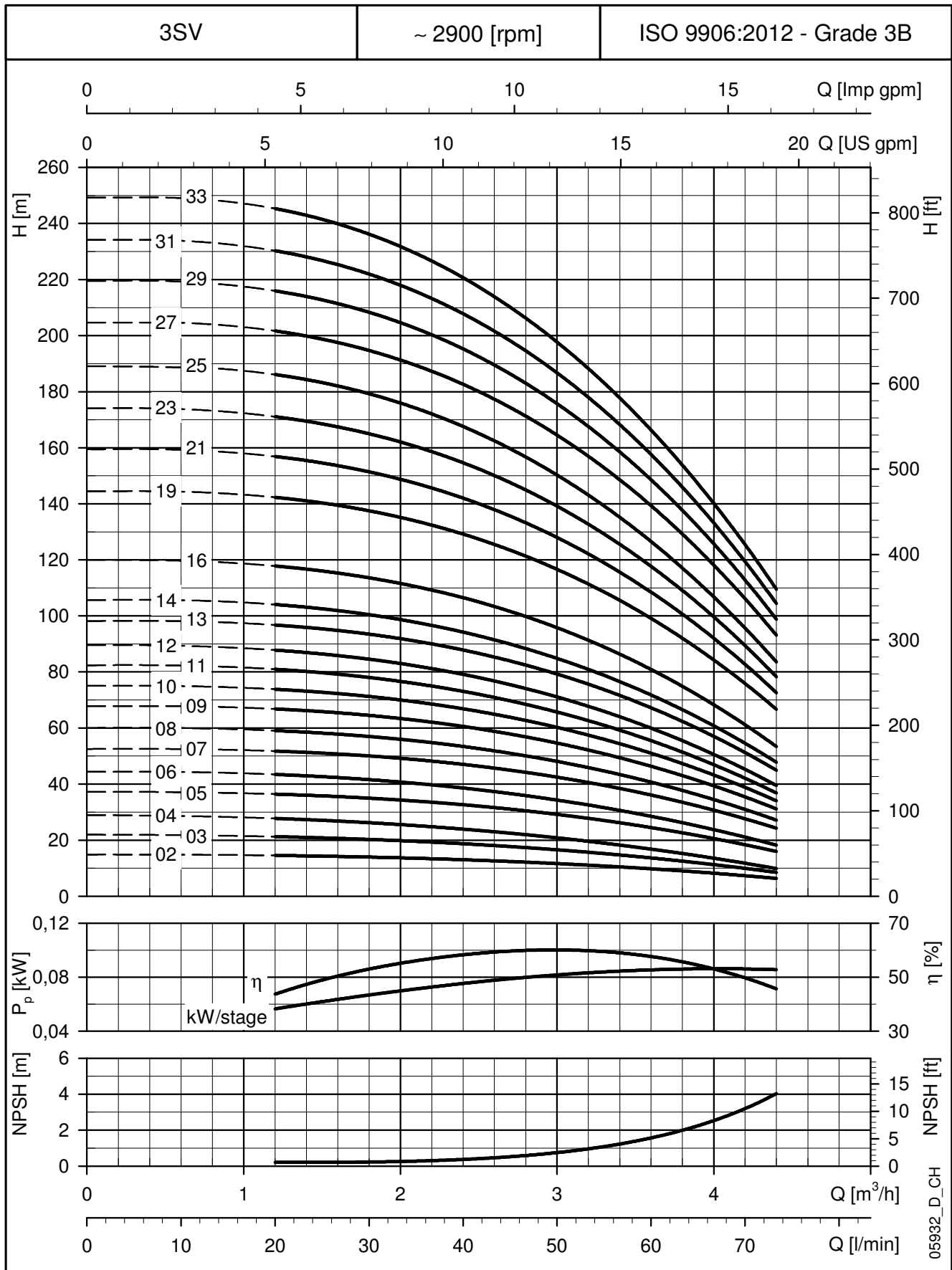

These performances are valid for liquids with density $\rho = 1.0 \text{ Kg/dm}^3$ and kinematic viscosity $\nu = 1 \text{ mm}^2/\text{sec}$.

5SV SERIES DIMENSIONS AND WEIGHTS AT 50 Hz, 2 POLES

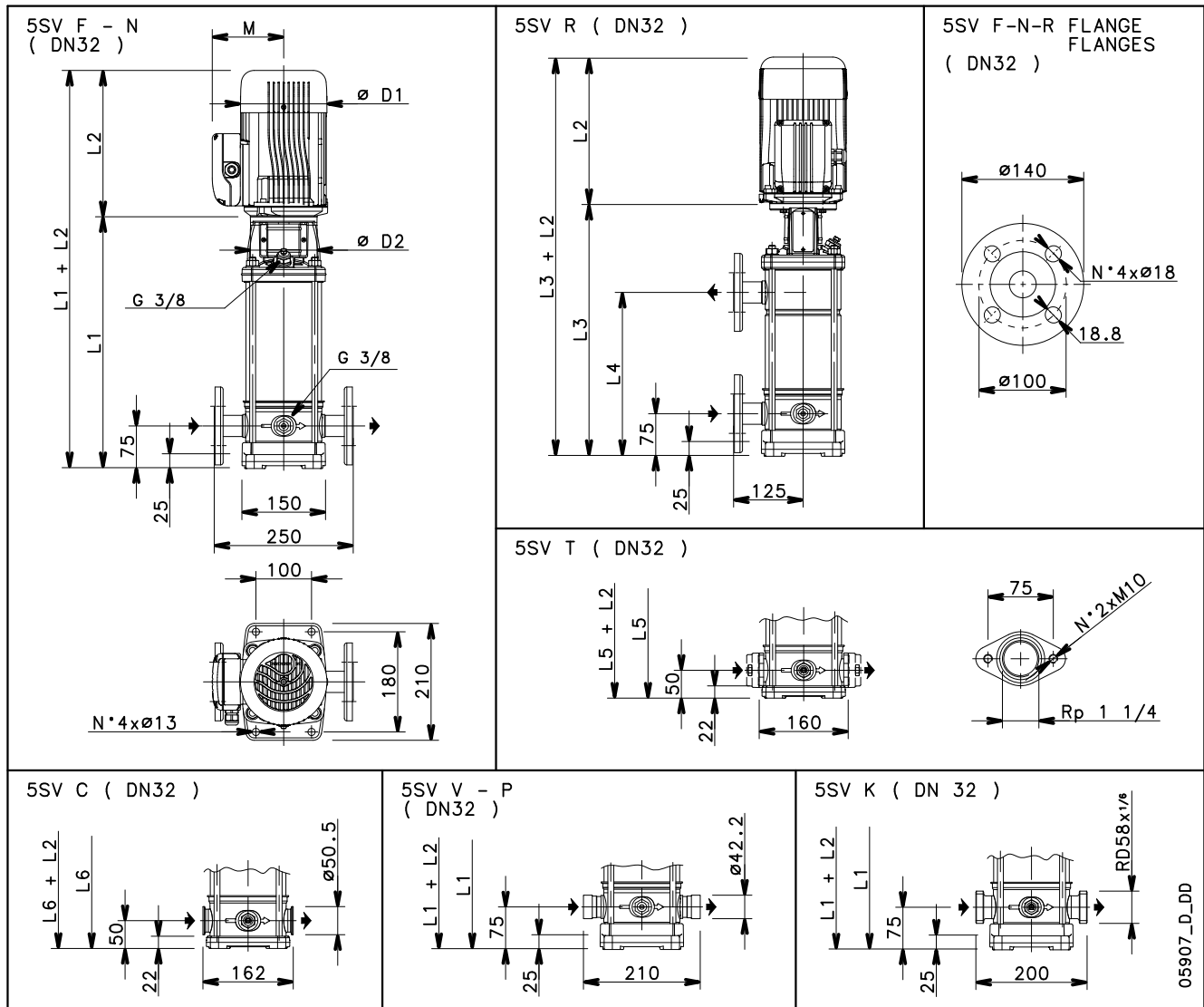

PUMP TYPE	MOTOR		DIMENSIONS (mm)													WEIGHT kg	
	kw	SIZE	L1	L2		L3	L4	L5	L6	M		D1		D2	PUMP	ELECTRIC	
5SV02..	0,37	71	268	209	209	-	-	243	243	111	111	120	120	105	8,4	13,2	
5SV03..	0,55	71	293	231	231	-	-	268	268	121	121	140	140	105	8,9	15,7	
5SV04..	0,55	71	318	231	231	-	-	293	293	121	121	140	140	105	9,4	16,1	
5SV05../D	0,75	80	353	226	263	-	-	328	328	121	129	140	155	120	10,5	20,1	
5SV06../D	1,1	80	378	263	263	-	-	353	353	137	129	155	155	120	11	22,4	
5SV07../D	1,1	80	403	263	263	403	242	378	378	137	129	155	155	120	11,5	22,9	
5SV08../D	1,1	80	428	263	263	428	267	403	403	137	129	155	155	120	12,1	23,5	
5SV09../D	1,5	90	463	263	263	463	292	438	438	137	129	155	155	140	12,7	26	
5SV10../D	1,5	90	488	263	263	488	317	463	463	137	129	155	155	140	13,1	26,5	
5SV11../D	1,5	90	513	263	263	513	342	488	488	137	129	155	155	140	13,6	27	
5SV12../D	2,2	90	538	298	298	538	367	513	513	151	134	174	174	140	14,1	32,3	
5SV13../D	2,2	90	563	298	298	563	392	538	538	151	134	174	174	140	14,6	32,8	
5SV14../D	2,2	90	588	298	298	588	417	563	563	151	134	174	174	140	15	33,2	
5SV15../D	2,2	90	613	298	298	613	442	588	588	151	134	174	174	140	15,5	33,7	
5SV16../D	2,2	90	638	298	298	638	467	613	613	151	134	174	174	140	16	34,2	
5SV18../D	3	100	698	-	298	698	517	673	673	-	134	-	174	160	18	39	
5SV21../D	3	100	773	-	298	773	592	748	748	-	134	-	174	160	19,4	40,4	
5SV23../D	4	112	823	-	319	823	642	-	798	-	154	-	197	160	20,4	47	
5SV25../D	4	112	873	-	319	873	692	-	848	-	154	-	197	160	21,3	48	
5SV28../D	4	112	948	-	319	948	767	-	923	-	154	-	197	160	23	49,4	
5SV30../D	5,5	132	1018	-	375	1018	817	-	993	-	168	-	214	300	28,1	65,7	
5SV33../D	5,5	132	1093	-	375	1093	892	-	1068	-	168	-	214	300	29,5	67,1	

5SV SERIES

OPERATING CHARACTERISTICS AT 50 Hz, 2 POLES

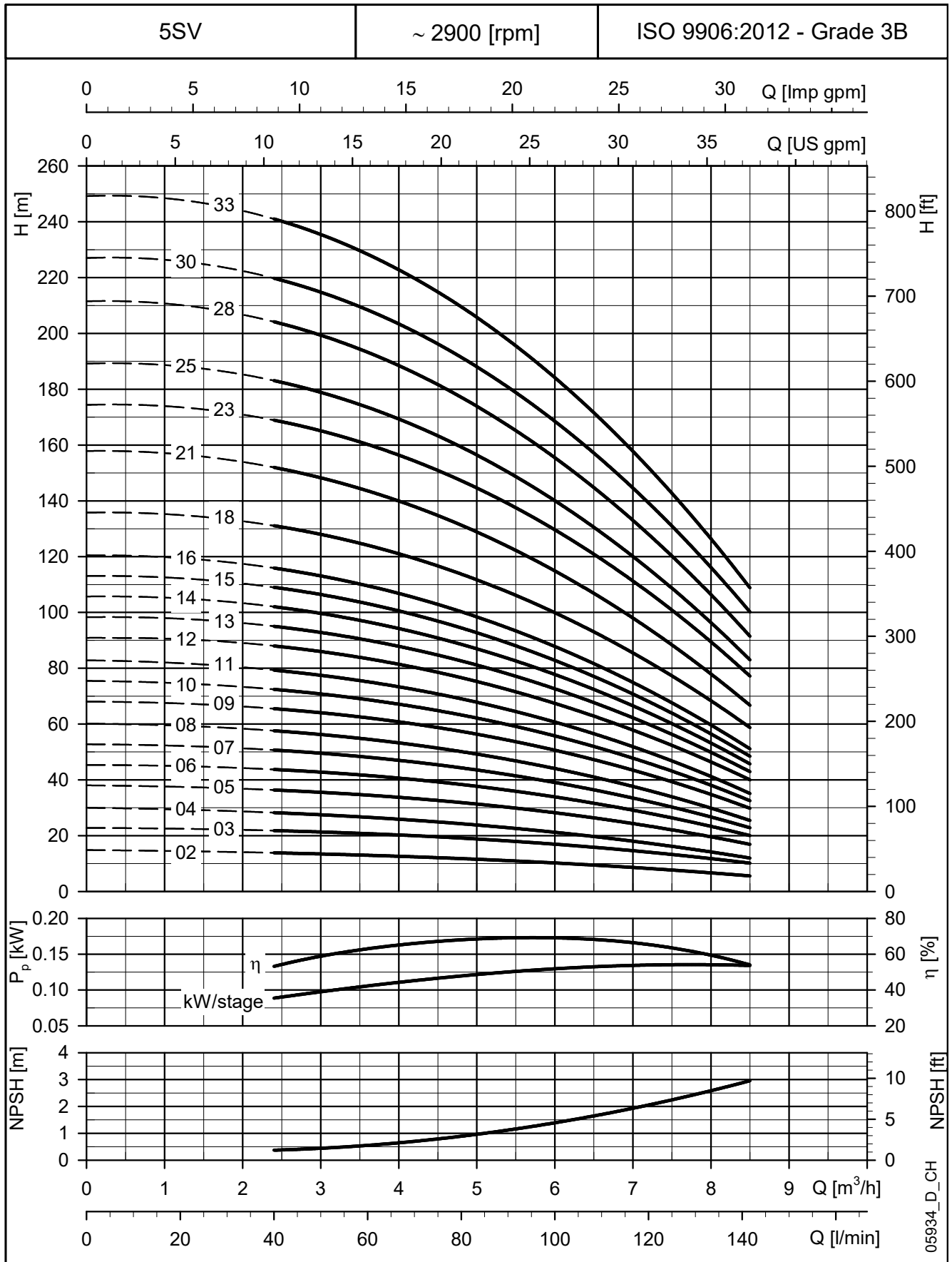

These performances are valid for liquids with density $\rho = 1.0 \text{ Kg/dm}^3$ and kinematic viscosity $\nu = 1 \text{ mm}^2/\text{sec}$.

10SV SERIES

DIMENSIONS AND WEIGHTS AT 50 Hz, 2 POLES

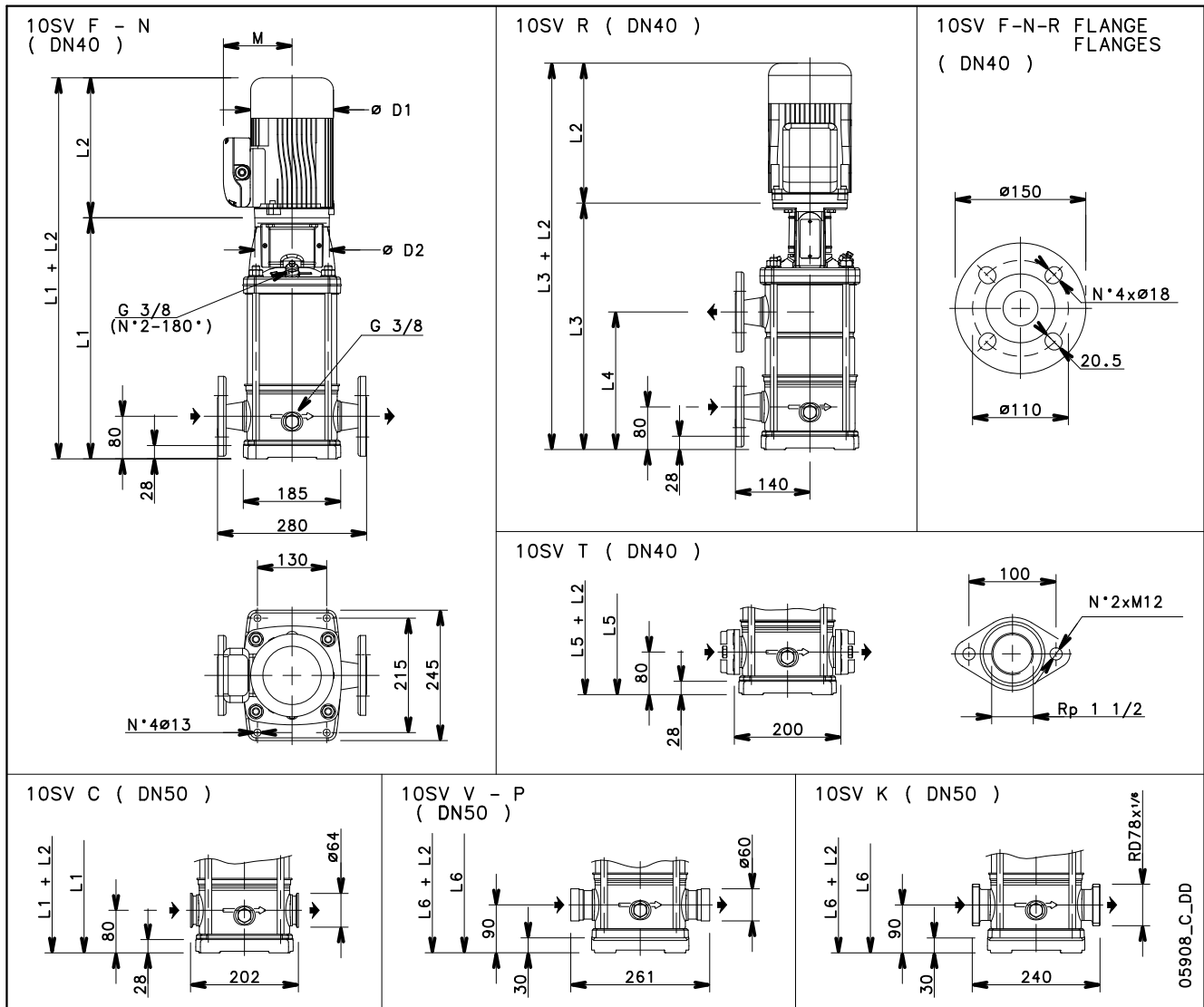

PUMP TYPE	MOTOR		DIMENSIONS (mm)												WEIGHT kg	
	kW	SIZE	L1	L2		L3	L4	L5	L6	M		D1		D2	PUMP	ELECTRIC
10SV01../D	0,75	80	357	226	263	-	-	357	367	121	129	140	155	120	14,2	24
10SV02../D	0,75	80	357	226	263	-	-	357	367	121	129	140	155	120	15,1	24,9
10SV03../D	1,1	80	389	263	263	-	-	389	399	137	129	155	155	120	16,1	27,6
10SV04../D	1,5	90	431	263	263	-	-	431	441	137	129	155	155	140	17,6	31
10SV05../D	2,2	90	463	298	298	463	259	463	473	151	134	174	174	140	18,5	36,7
10SV06../D	2,2	90	495	298	298	495	291	495	505	151	134	174	174	140	19,7	37,9
10SV07../D	3	100	537	-	298	537	323	537	547	-	134	-	174	160	21,5	42,5
10SV08../D	3	100	569	-	298	569	355	569	579	-	134	-	174	160	22,4	43,4
10SV09../D	4	112	601	-	319	601	387	601	611	-	154	-	197	160	23,3	49,7
10SV10../D	4	112	633	-	319	633	419	633	643	-	154	-	197	160	24,3	50,7
10SV11../D	4	112	665	-	319	665	451	665	675	-	154	-	197	160	25,2	52
10SV13../D	5,5	132	796	-	375	796	515	796	806	-	168	-	214	300	33,1	71
10SV15../D	5,5	132	860	-	375	860	579	-	870	-	168	-	214	300	35	73
10SV17../D	7,5	132	924	-	367	924	643	-	934	-	191	-	256	300	36,9	93
10SV18../D	7,5	132	956	-	367	956	675	-	966	-	191	-	256	300	37,8	94
10SV20../D	7,5	132	1020	-	367	1020	739	-	1030	-	191	-	256	300	39,6	96
10SV21../D	11	160	1082	-	428	1082	771	-	1092	-	191	-	256	350	42,2	113

10SV SERIES

OPERATING CHARACTERISTICS AT 50 Hz, 2 POLES

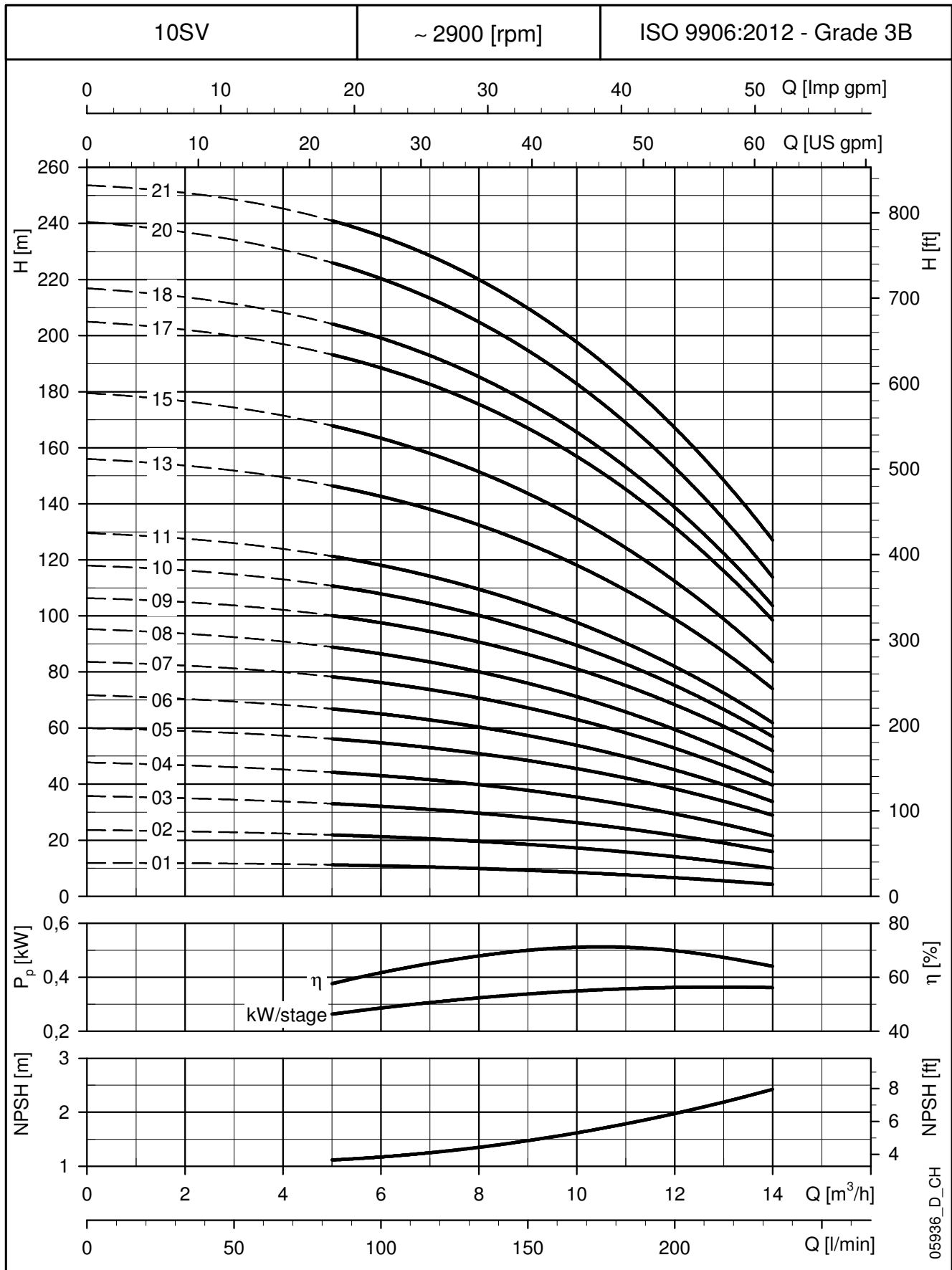

These performances are valid for liquids with density $\rho = 1.0 \text{ Kg/dm}^3$ and kinematic viscosity $\nu = 1 \text{ mm}^2/\text{sec}$.

15SV SERIES

DIMENSIONS AND WEIGHTS AT 50 Hz, 2 POLES

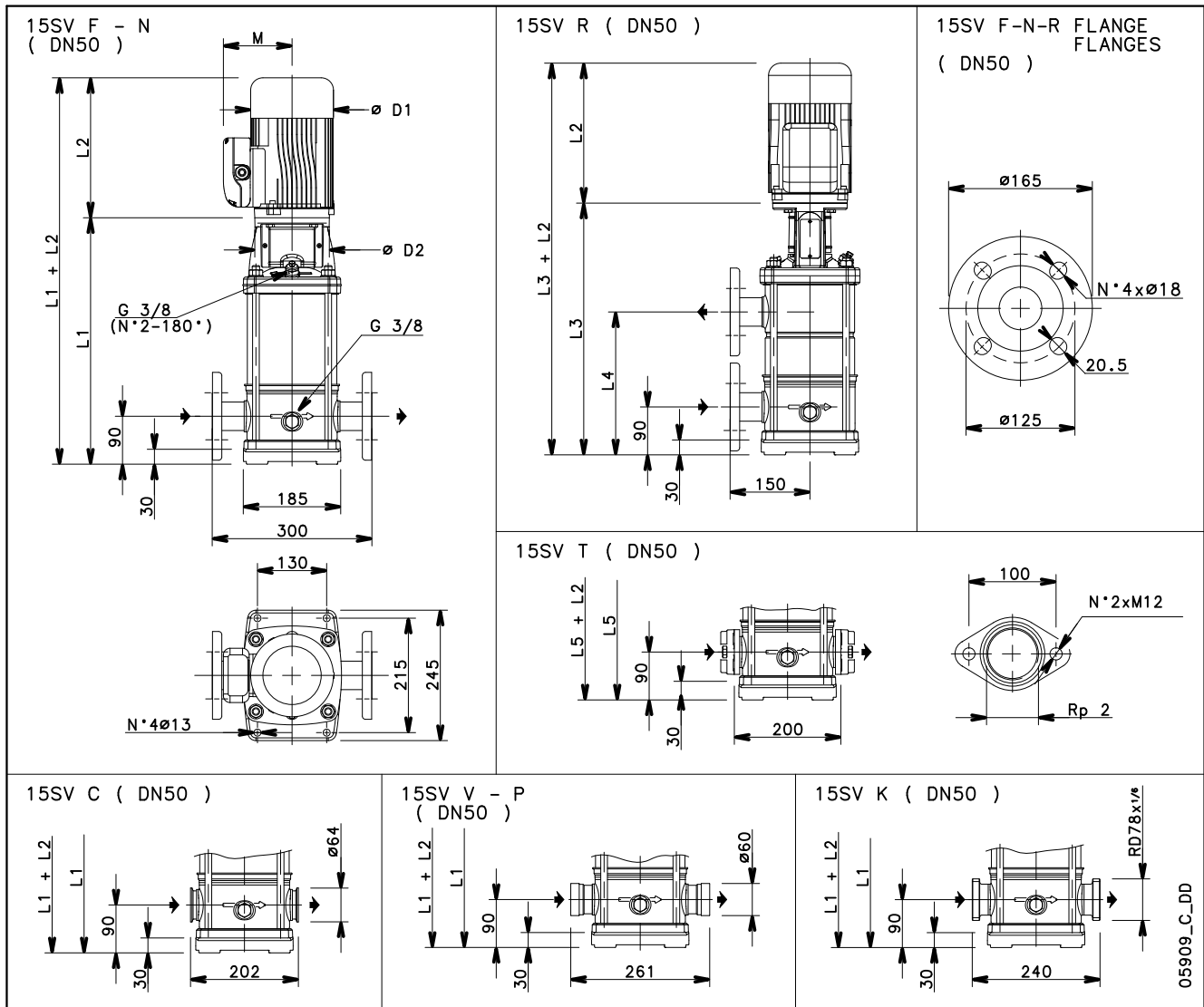

PUMP TYPE	MOTOR		DIMENSIONS (mm)											WEIGHT kg	
	kW	SIZE	L1	L2		L3	L4	L5	M		D1		D2	PUMP	ELECTRIC
				1 ~	3 ~				1 ~	3 ~	1 ~	3 ~			
15SV01../D	1,1	80	399	263	263	-	-	399	137	129	155	155	120	15	26,8
15SV02../D	2,2	90	409	298	298	-	-	409	151	134	174	174	140	16,8	34,7
15SV03../D	3	100	467	-	298	-	-	467	-	134	-	174	160	19	40
15SV04../D	4	112	515	-	319	515	301	515	-	154	-	197	160	20,3	46,8
15SV05../D	4	112	563	-	319	563	349	563	-	154	-	197	160	21,5	47,9
15SV06../D	5,5	132	678	-	375	678	397	678	-	168	-	214	300	28,9	67
15SV07../D	5,5	132	726	-	375	726	445	726	-	168	-	214	300	30,2	68
15SV08../D	7,5	132	774	-	367	774	493	774	-	191	-	256	300	31,5	88
15SV09../D	7,5	132	822	-	367	822	541	822	-	191	-	256	300	32,8	90
15SV10../D	11	160	900	-	428	900	589	900	-	191	-	256	350	37	108
15SV11../D	11	160	948	-	428	948	637	-	-	191	-	256	350	38,3	109
15SV13../D	11	160	1044	-	428	1044	733	-	-	191	-	256	350	41	112
15SV15../D	15	160	1140	-	494	1140	829	-	-	240	-	313	350	43,7	146
15SV17../D	15	160	1236	-	494	1236	925	-	-	240	-	313	350	46,7	149

15SV SERIES

OPERATING CHARACTERISTICS AT 50 Hz, 2 POLES

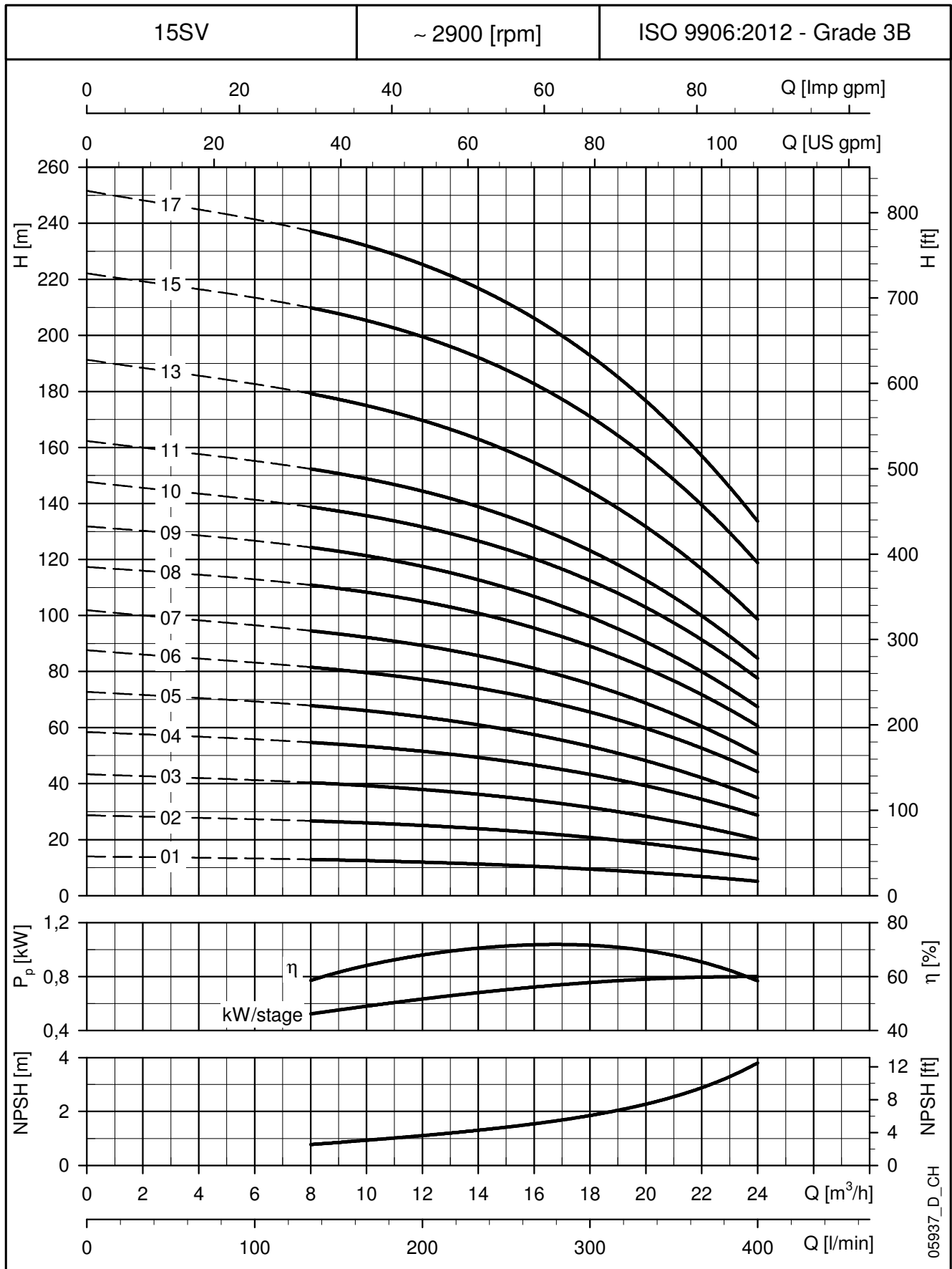

These performances are valid for liquids with density $\rho = 1.0 \text{ Kg/dm}^3$ and kinematic viscosity $\nu = 1 \text{ mm}^2/\text{sec}$.

22SV SERIES DIMENSIONS AND WEIGHTS AT 50 Hz, 2 POLES

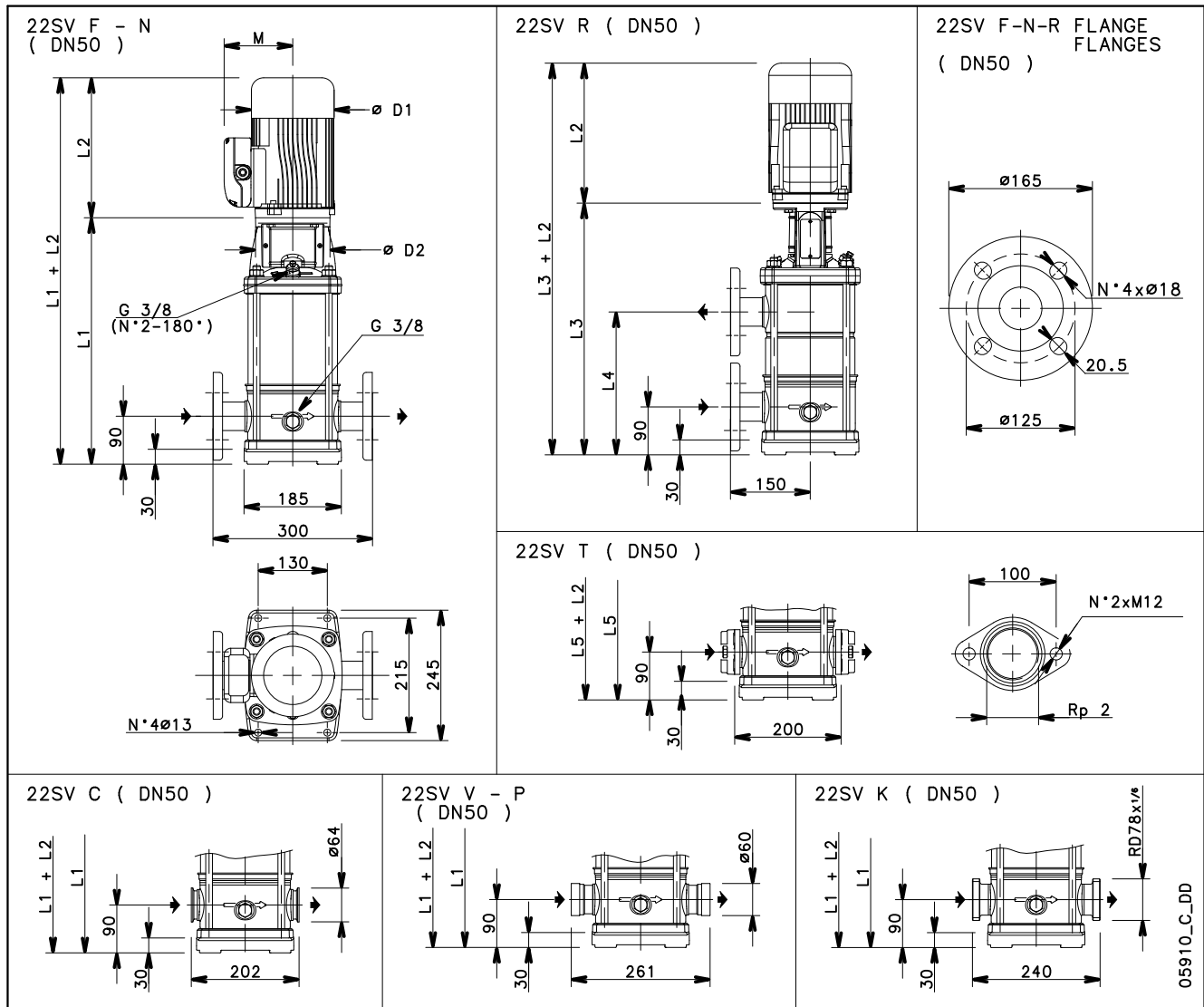

PUMP TYPE	MOTOR		DIMENSIONS (mm)											WEIGHT kg	
	kw	SIZE	L1	L2		L3	L4	L5	M		D1		D2	PUMP	ELECTRIC
				1 ~	3 ~				1 ~	3 ~	1 ~	3 ~			
22SV01../D	1,1	80	399	263	263	-	-	399	137	129	155	155	120	15,5	26,9
22SV02../D	2,2	90	409	298	298	-	-	409	151	134	174	174	140	17,2	35,4
22SV03../D	3	100	467	-	298	-	-	467	-	134	-	174	160	19,4	40,4
22SV04../D	4	112	515	-	319	515	301	515	-	154	-	197	160	20,7	47,1
22SV05../D	5,5	132	630	-	375	630	349	630	-	168	-	214	300	26,7	65
22SV06../D	7,5	132	678	-	367	678	397	678	-	191	-	256	300	28	84
22SV07../D	7,5	132	726	-	367	726	445	726	-	191	-	256	300	29,3	86
22SV08../D	11	160	804	-	428	804	493	804	-	191	-	256	350	33,1	104
22SV09../D	11	160	852	-	428	852	541	852	-	191	-	256	350	34,4	105
22SV10../D	11	160	900	-	428	900	589	900	-	191	-	256	350	35,8	107
22SV12../D	15	160	996	-	494	996	685	-	-	240	-	313	350	38,4	141
22SV14../D	15	160	1092	-	494	1092	781	-	-	240	-	313	350	41,1	144
22SV17../D	18,5	160	1236	-	494	1236	925	-	-	240	-	313	350	45,1	156

22SV SERIES

OPERATING CHARACTERISTICS AT 50 Hz, 2 POLES

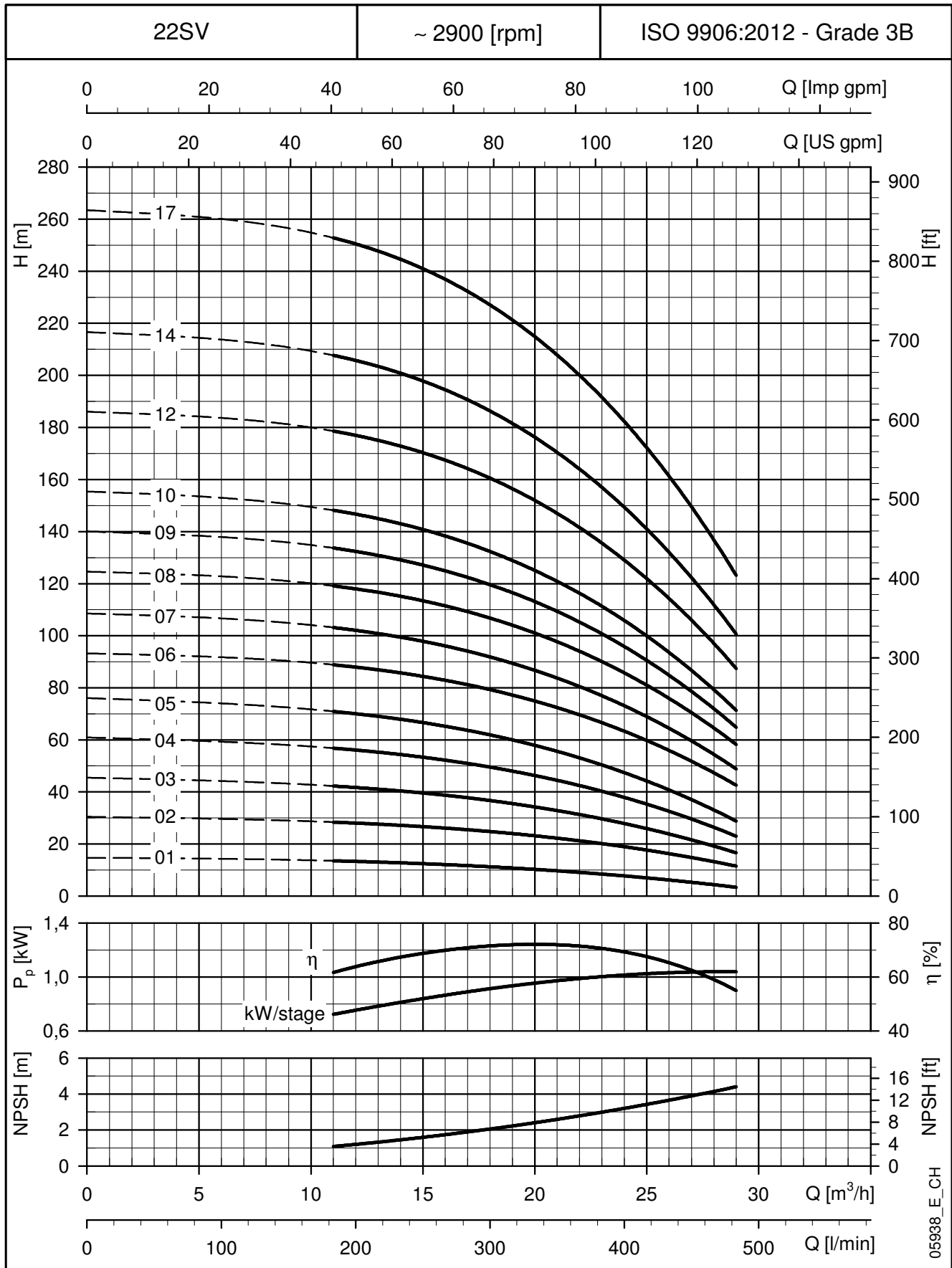

These performances are valid for liquids with density $\rho = 1.0 \text{ Kg/dm}^3$ and kinematic viscosity $\nu = 1 \text{ mm}^2/\text{sec}$.

33SV SERIES DIMENSIONS AND WEIGHTS AT 50 Hz, 2 POLES

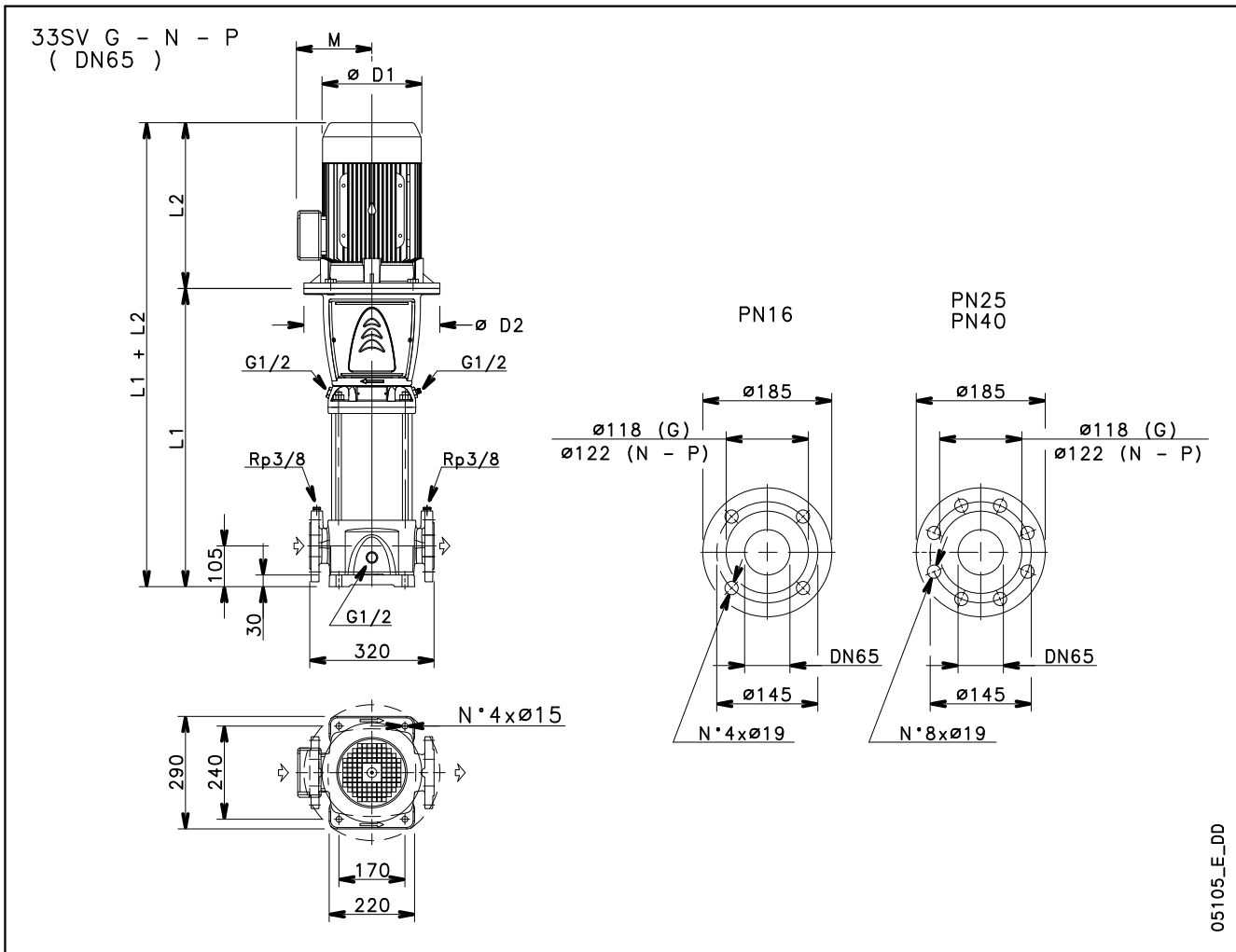

05105_E_DD

PUMP TYPE	MOTOR		DIMENSIONS (mm)						WEIGHT kg	
	kW	SIZE	L1	L2	D1	D2	M	PN	PUMP	ELECTRIC PUMP
33SV1/1A../D	2,2	90	489	298	174	164	134	16	52	73
33SV1../D	3	100	489	298	174	164	134	16	52	73
33SV2/2A../D	4	112	564	319	197	164	154	16	56	82,5
33SV2/1A../D	4	112	564	319	197	164	154	16	56	82,5
33SV2../D	5,5	132	584	375	214	300	168	16	61	98,5
33SV3/2A../D	5,5	132	659	375	214	300	168	16	65	103
33SV3/1A../D	7,5	132	659	367	256	300	191	16	65	121
33SV3../D	7,5	132	659	367	256	300	191	16	65	121
33SV4/2A../D	7,5	132	734	367	256	300	191	16	69	125
33SV4/1A../D	11	160	769	428	256	350	191	16	73	143
33SV4../D	11	160	769	428	256	350	191	16	73	143
33SV5/2A../D	11	160	844	428	256	350	191	16	77	147
33SV5/1A../D	11	160	844	428	256	350	191	16	77	147
33SV5../D	15	160	844	494	313	350	240	16	77	179
33SV6/2A../D	15	160	919	494	313	350	240	16	81	183
33SV6/1A../D	15	160	919	494	313	350	240	25	81	183
33SV6../D	15	160	919	494	313	350	240	25	81	183
33SV7/2A../D	15	160	994	494	313	350	240	25	84	186
33SV7/1A../D	18,5	160	994	494	313	350	240	25	84	195
33SV7../D	18,5	160	994	494	313	350	240	25	84	195
33SV8/2A../D	18,5	160	1069	494	313	350	240	25	88	199
33SV8/1A../D	18,5	160	1069	494	313	350	240	25	88	199
33SV8../D	22	180	1069	494	313	350	240	25	89	210
33SV9/2A../D	22	180	1144	494	313	350	240	25	93	214
33SV9/1A../D	22	180	1144	494	313	350	240	25	93	214
33SV9../D	22	180	1144	494	313	350	240	25	93	214
33SV10/2A../D	22	180	1219	494	313	350	240	25	97	218
33SV10/1A../D	30	200	1219	671	408	400	285	25	104	312
33SV10../D	30	200	1219	671	408	400	285	25	104	312
33SV11/2A../D	30	200	1294	671	408	400	285	40	118	326
33SV11/1A../D	30	200	1294	671	408	400	285	40	118	326
33SV11../D	30	200	1294	671	408	400	285	40	118	326
33SV12/2A../D	30	200	1369	671	408	400	285	40	122	330
33SV12/1A../D	30	200	1369	671	408	400	285	40	122	330
33SV12../D	30	200	1369	671	408	400	285	40	122	330
33SV13/2A../D	30	200	1444	671	408	400	285	40	127	335
33SV13/1A../D	30	200	1444	671	408	400	285	40	127	335

33SV SERIES

OPERATING CHARACTERISTICS AT 50 Hz, 2 POLES

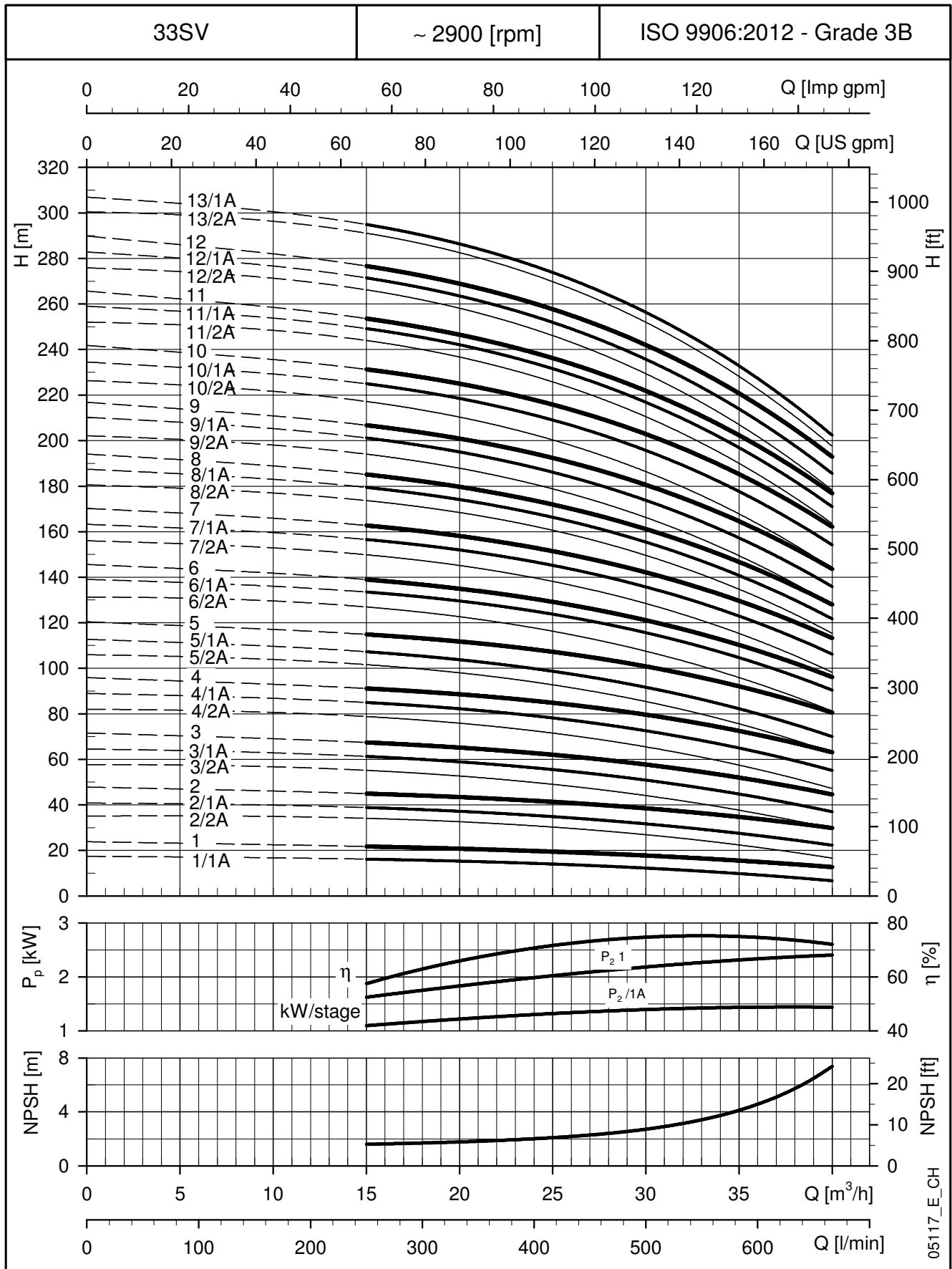

These performances are valid for liquids with density $\rho = 1.0 \text{ Kg/dm}^3$ and kinematic viscosity $\nu = 1 \text{ mm}^2/\text{sec}$.

46SV SERIES DIMENSIONS AND WEIGHTS AT 50 Hz, 2 POLES

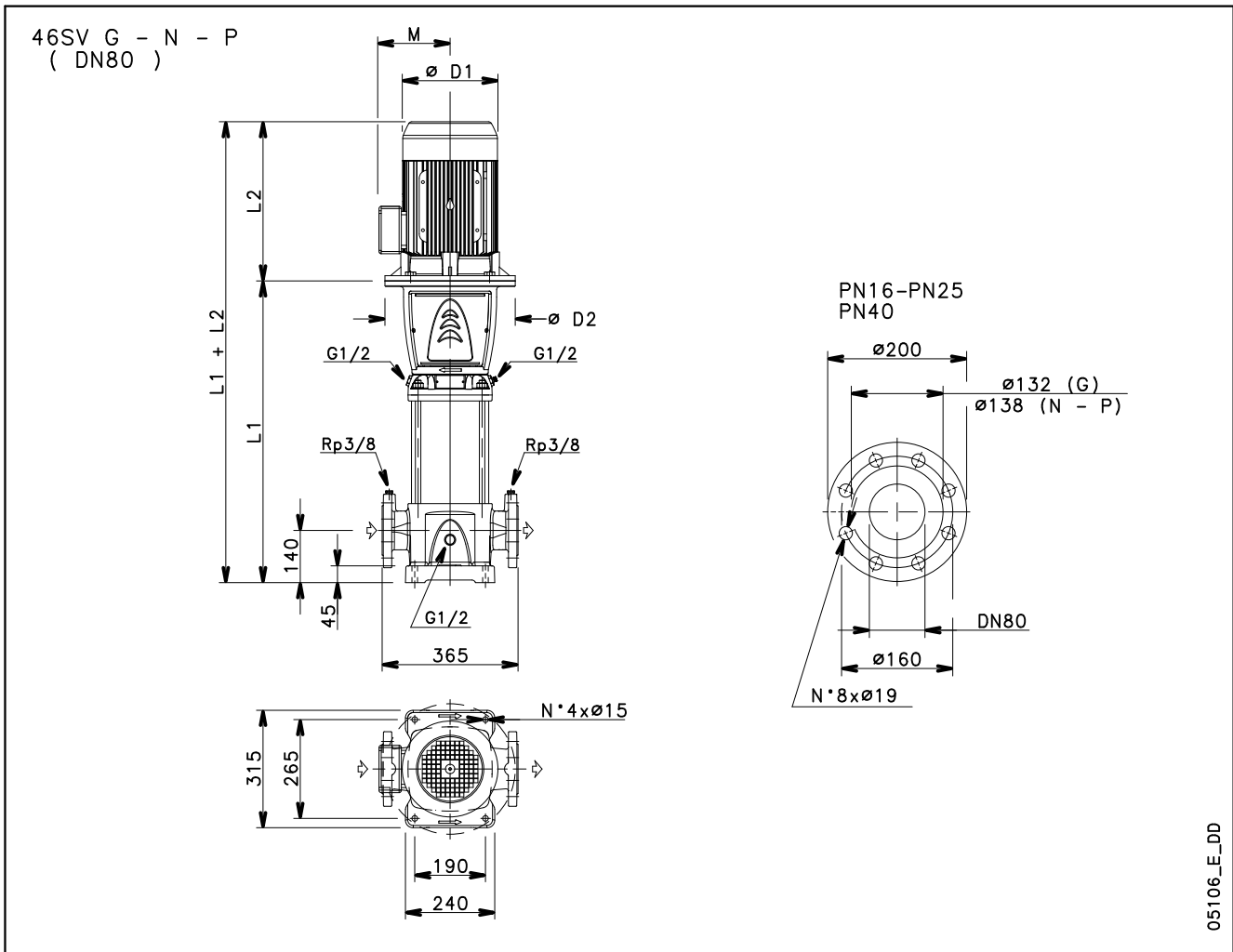

PUMP TYPE	MOTOR		DIMENSIONS (mm)							WEIGHT kg	
	kW	SIZE	L1	L2	D1	D2	M	PN	PUMP	ELECTRIC PUMP	
46SV1/1A../D	3	100	529	298	174	164	134	16	58	79	
46SV1../D	4	112	529	319	197	164	154	16	58	84,5	
46SV2/2A../D	5,5	132	624	375	214	300	168	16	66	104	
46SV2../D	7,5	132	624	367	256	300	191	16	66	122	
46SV3/2A../D	11	160	734	428	256	350	191	16	74	144	
46SV3../D	11	160	734	428	256	350	191	16	74	144	
46SV4/2A../D	15	160	809	494	313	350	240	16	78	180	
46SV4../D	15	160	809	494	313	350	240	16	78	180	
46SV5/2A../D	18,5	160	884	494	313	350	240	16	82	193	
46SV5../D	18,5	160	884	494	313	350	240	16	82	193	
46SV6/2A../D	22	180	959	494	313	350	240	25	87	208	
46SV6../D	22	180	959	494	313	350	240	25	87	208	
46SV7/2A../D	30	200	1034	671	408	400	285	25	97	305	
46SV7../D	30	200	1034	671	408	400	285	25	97	305	
46SV8/2A../D	30	200	1109	671	408	400	285	25	101	309	
46SV8../D	30	200	1109	671	408	400	285	25	101	309	
46SV9/2A../D	30	200	1184	671	408	400	285	25	105	313	
46SV9../D	37	200	1184	671	408	400	285	25	105	329	
46SV10/2A../D	37	200	1259	671	408	400	285	40	114	338	

46SV SERIES

OPERATING CHARACTERISTICS AT 50 Hz, 2 POLES

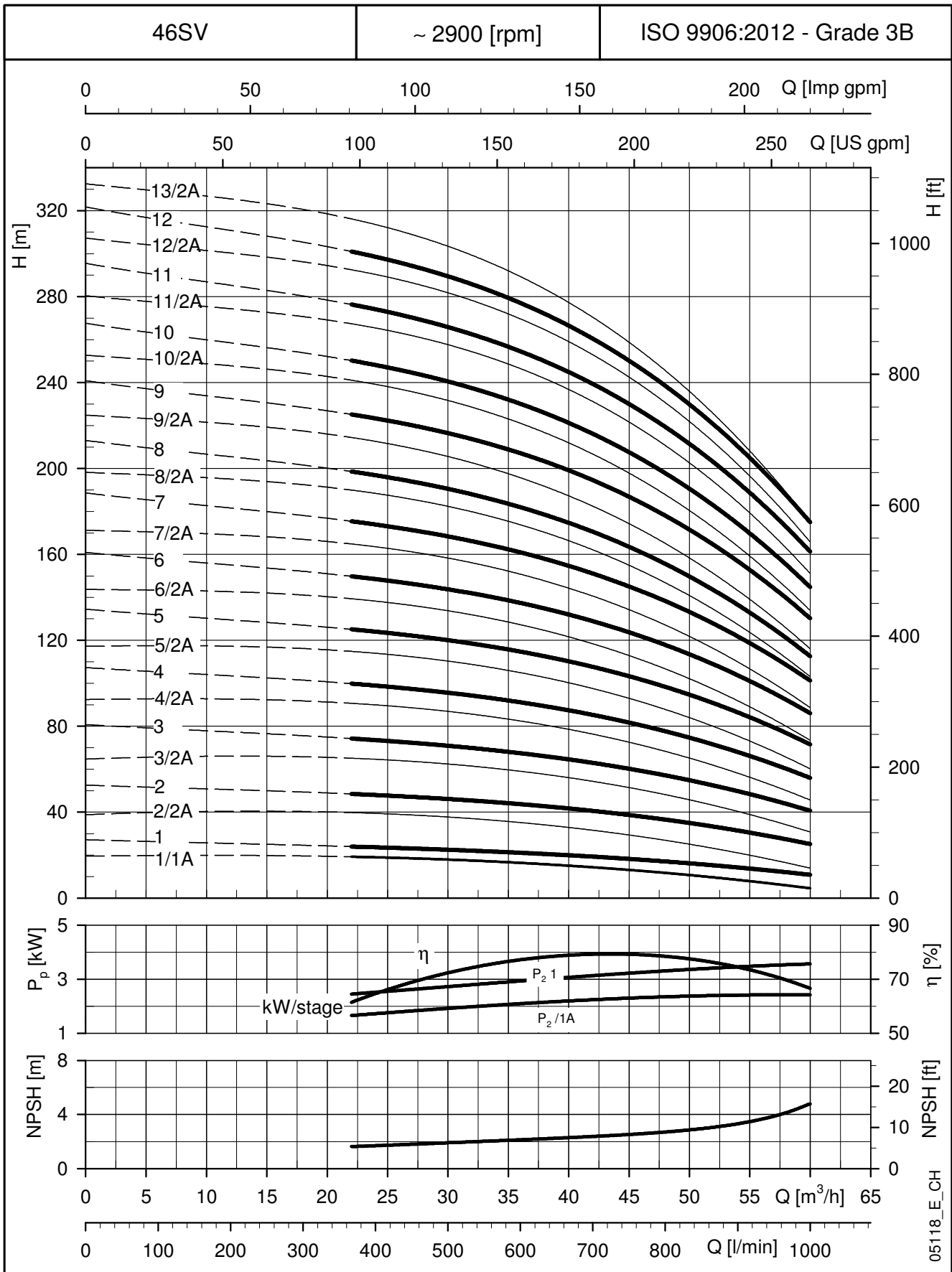

These performances are valid for liquids with density $\rho = 1.0 \text{ Kg/dm}^3$ and kinematic viscosity $\nu = 1 \text{ mm}^2/\text{sec}$.

66SV SERIES DIMENSIONS AND WEIGHTS AT 50 Hz, 2 POLES

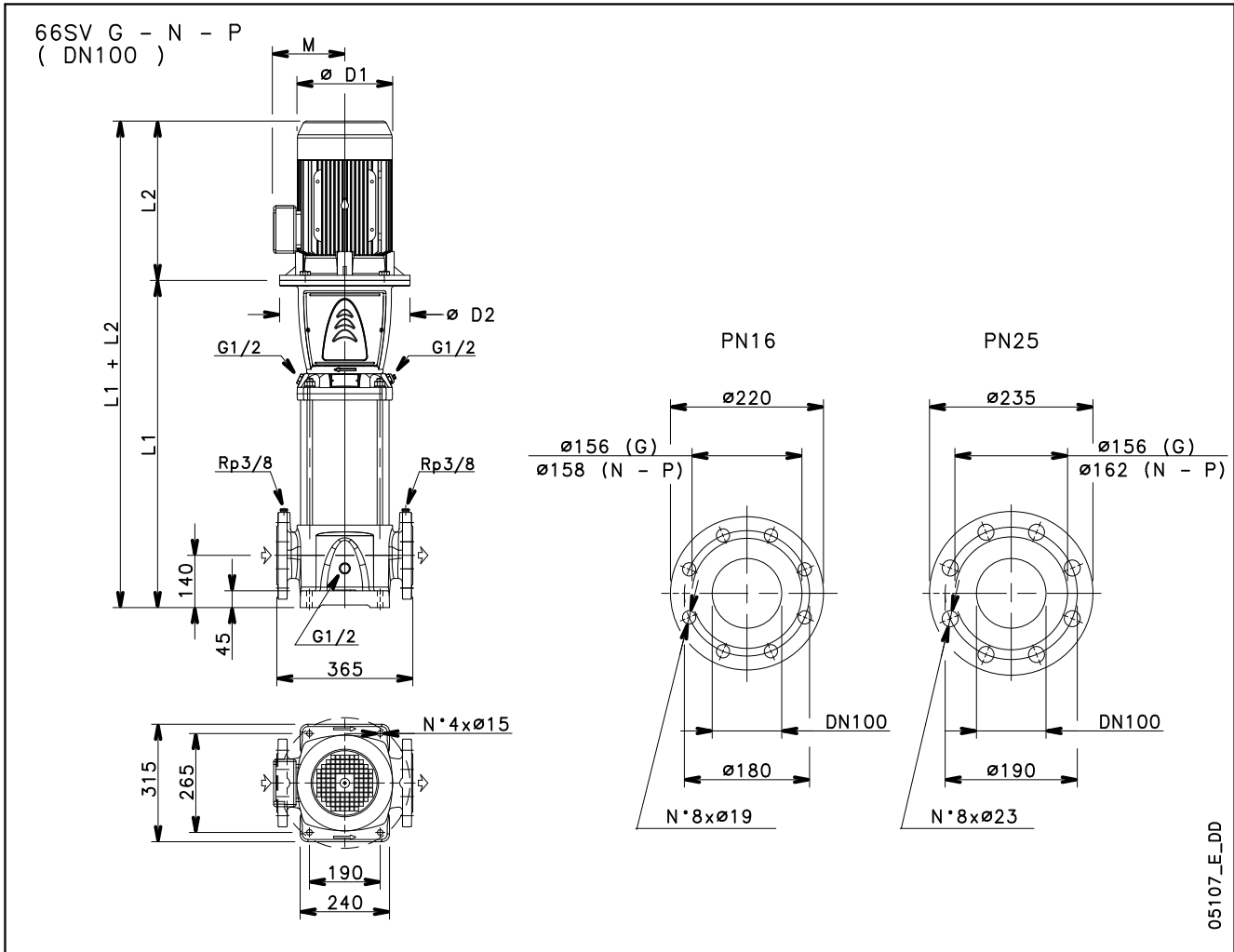

05107_E_DD

PUMP TYPE	MOTOR		DIMENSIONS (mm)						WEIGHT kg	
	kW	SIZE	L1	L2	D1	D2	M	PN	PUMP	ELECTRIC PUMP
66SV1/1A../D	4	112	554	319	197	164	154	16	66	92,5
66SV1../D	5,5	132	574	375	214	300	168	16	72	110
66SV2/2A../D	7,5	132	664	367	256	300	191	16	77	133
66SV2/1A../D	11	160	699	428	256	350	191	16	81	151
66SV2../D	11	160	699	428	256	350	191	16	81	151
66SV3/2A../D	15	160	789	494	313	350	240	16	86	188
66SV3/1A../D	15	160	789	494	313	350	240	16	86	188
66SV3../D	18,5	160	789	494	313	350	240	16	86	197
66SV4/2A../D	18,5	160	879	494	313	350	240	16	92	203
66SV4/1A../D	22	180	879	494	313	350	240	16	93	214
66SV4../D	22	180	879	494	313	350	240	16	93	214
66SV5/2A../D	30	200	969	671	408	400	285	16	105	313
66SV5/1A../D	30	200	969	671	408	400	285	16	105	313
66SV5../D	30	200	969	671	408	400	285	16	105	313
66SV6/2A../D	30	200	1059	671	408	400	285	25	113	321
66SV6/1A../D	30	200	1059	671	408	400	285	25	113	321
66SV6../D	37	200	1059	671	408	400	285	25	113	337
66SV7/2A../D	37	200	1149	671	408	400	285	25	118	342
66SV7/1A../D	37	200	1149	671	408	400	285	25	118	342

PUMP TYPE	MOTOR		DIMENSIONS (mm)						WEIGHT kg	
	kW	SIZE	L1	L2	D1	D2	M	PN	PUMP	ELECTRIC PUMP
66SV7../D	45	225	1149	701	460	450	309	25	122	414
66SV8/2A../D	45	225	1239	701	460	450	309	25	127	419
66SV8/1A../D	45	225	1239	701	460	450	309	25	127	419
66SV8../D	45	225	1239	701	460	450	309	25	127	419

66SV SERIES

OPERATING CHARACTERISTICS AT 50 Hz, 2 POLES

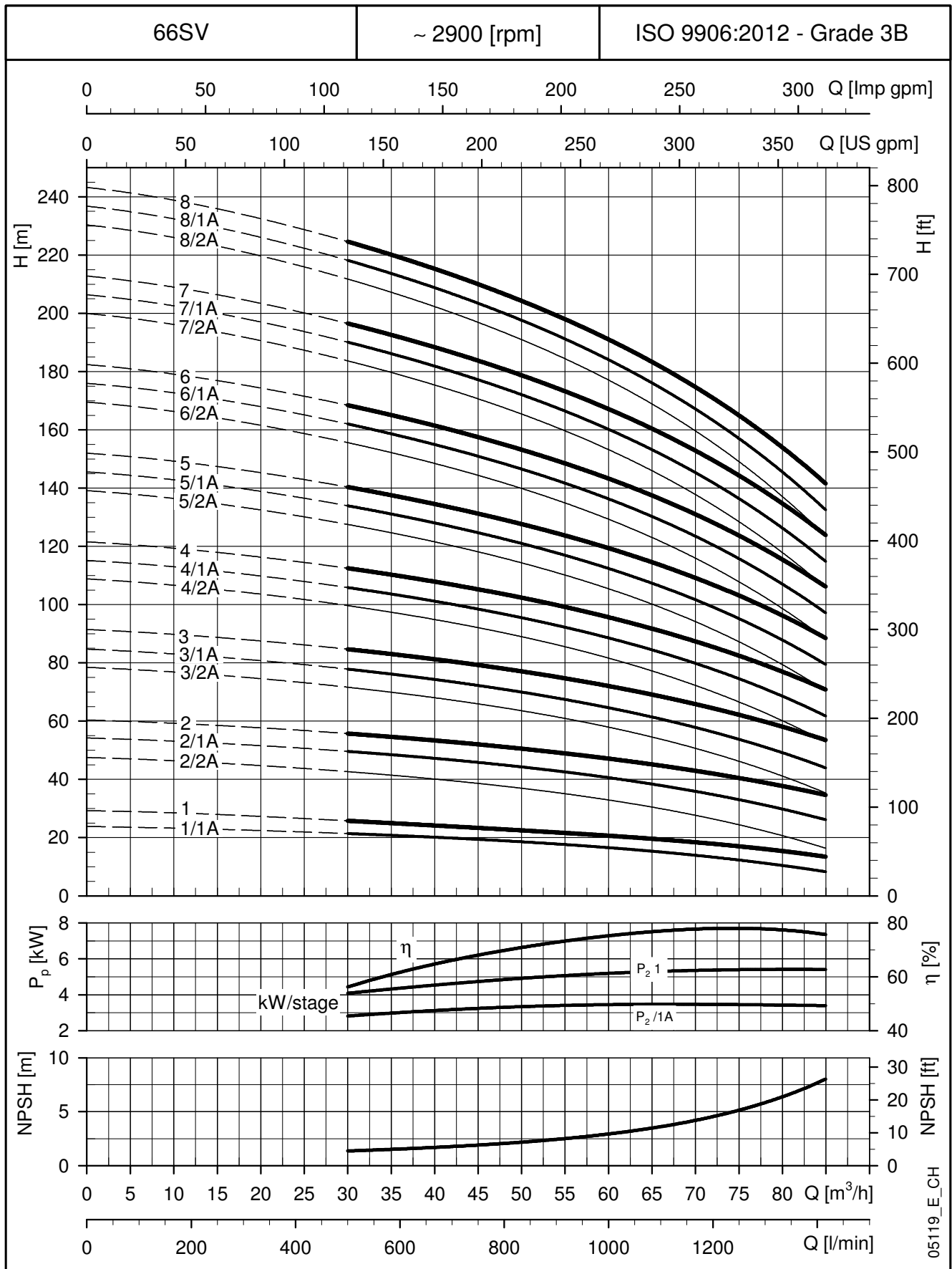

These performances are valid for liquids with density $\rho = 1.0 \text{ Kg/dm}^3$ and kinematic viscosity $\nu = 1 \text{ mm}^2/\text{sec}$.

92SV SERIES DIMENSIONS AND WEIGHTS AT 50 Hz, 2 POLES

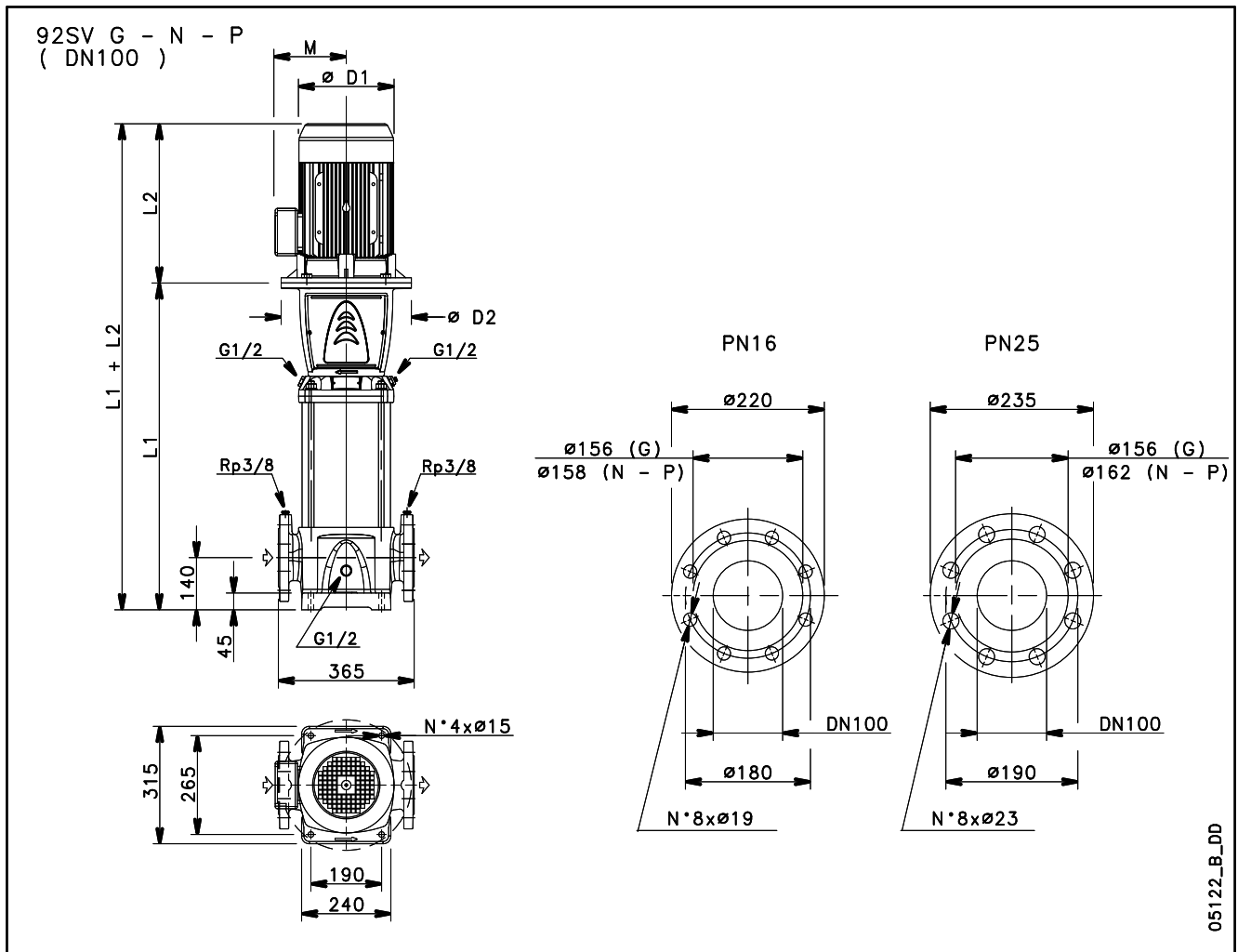

PUMP TYPE	MOTOR		DIMENSIONS (mm)						WEIGHT kg	
	kW	SIZE	L1	L2	D1	D2	M	PN	PUMP	ELECTRIC
92SV1/1A../D	5,5	132	574	375	214	300	168	16	71	109
92SV1../D	7,5	132	574	367	256	300	191	16	71	127
92SV2/2A../D	11	160	699	428	256	350	191	16	80	150
92SV2../D	15	160	699	494	313	350	240	16	80	182
92SV3/2A../D	18,5	160	789	494	313	350	240	16	86	197
92SV3../D	22	180	789	494	313	350	240	16	87	208
92SV4/2A../D	30	200	879	671	408	400	285	16	99	307
92SV4../D	30	200	879	671	408	400	285	16	99	307
92SV5/2A../D	37	200	969	671	408	400	285	25	107	331
92SV5../D	37	200	969	671	408	400	285	25	107	331
92SV6/2A../D	45	225	1059	701	460	450	309	25	116	408
92SV6../D	45	225	1059	701	460	450	309	25	116	408
92SV7/2A../D	45	225	1149	701	460	450	309	25	121	413

92SV SERIES

OPERATING CHARACTERISTICS AT 50 Hz, 2 POLES

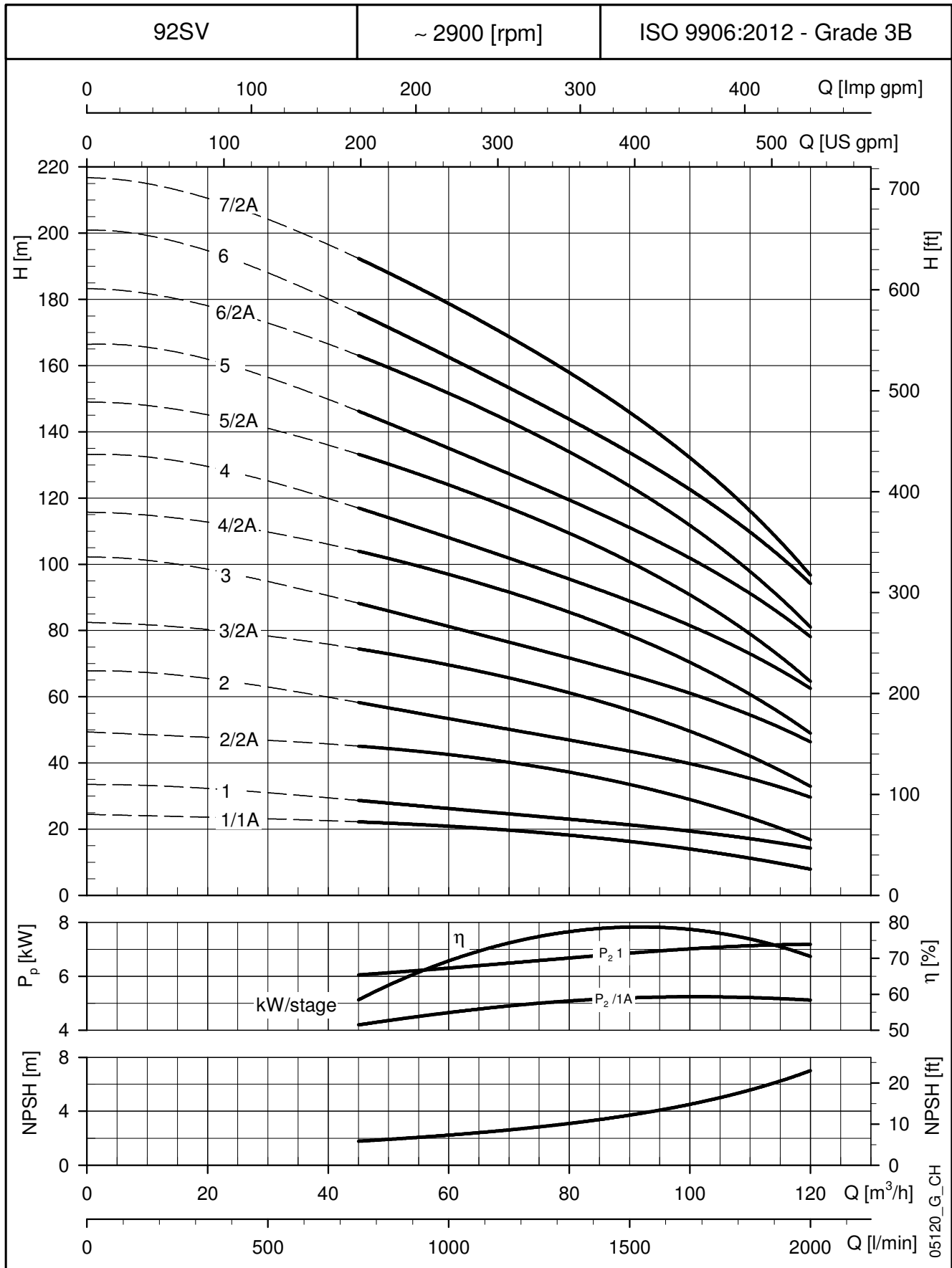

These performances are valid for liquids with density $\rho = 1.0 \text{ Kg/dm}^3$ and kinematic viscosity $\nu = 1 \text{ mm}^2/\text{sec}$.

125SV SERIES DIMENSIONS AND WEIGHTS AT 50 Hz, 2 POLES

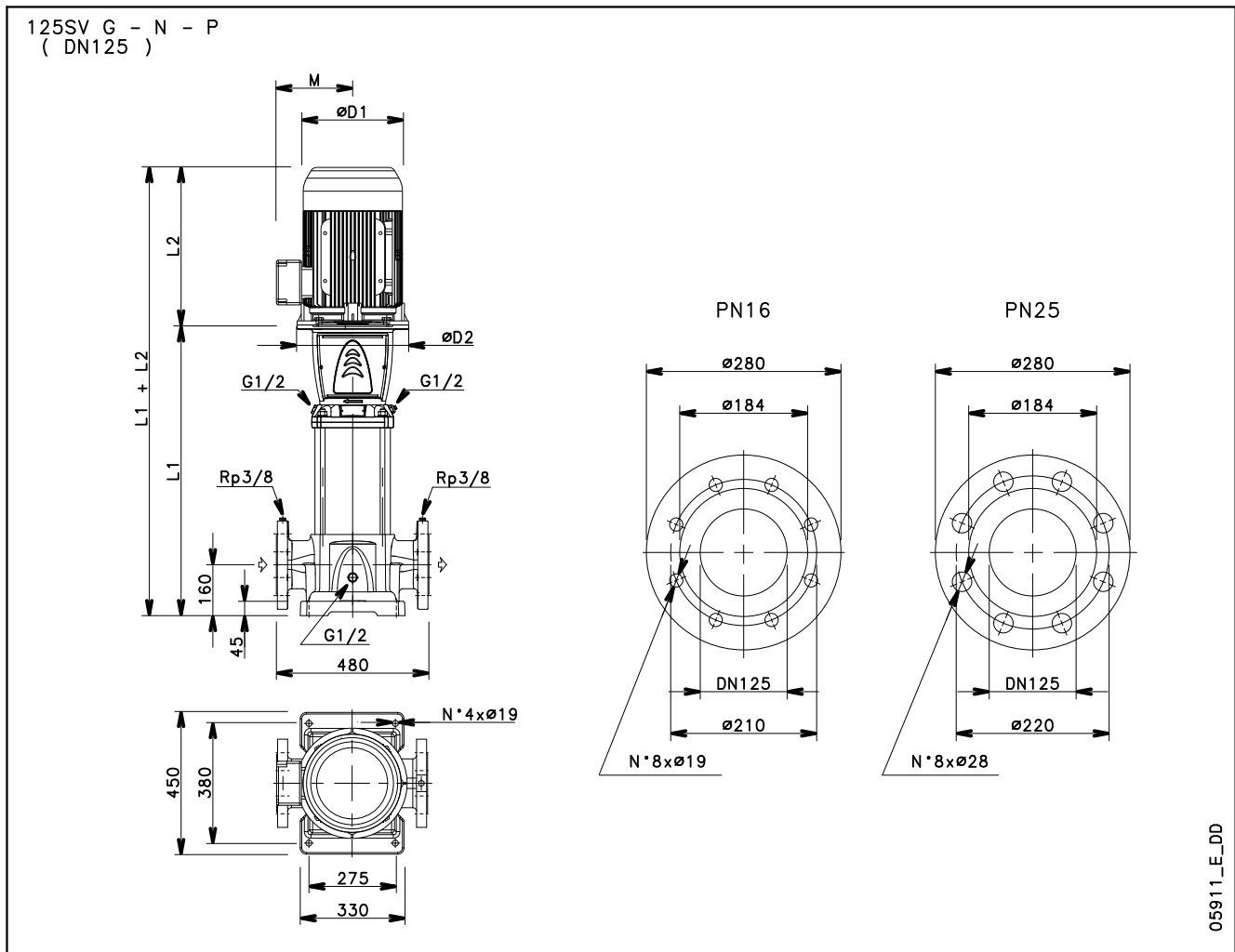

PUMP TYPE	MOTOR		DIMENSIONS (mm)						WEIGHT kg	
	kW	SIZE	L1	L2	D1	D2	M	PN	PUMP	ELECTRIC PUMP
125SV1../D	7,5	132	693	367	256	300	191	16	116	172
125SV2../D	15	160	878	494	313	350	240	16	131	233
125SV3../D	22	180	1028	494	313	350	240	16	143	265
125SV4../D	30	200	1178	671	408	400	285	16	161	369
125SV5../D	37	200	1328	671	408	400	285	16	172	396
125SV6../D	45	225	1478	701	460	450	309	16	187	479
125SV7../D	55	250	1658	767	502	550	362	25	216	658
125SV8/2A../D	55	250	1808	767	502	550	362	25	229	671

125sv-2p50-en_d_td

125SV SERIES

OPERATING CHARACTERISTICS AT 50 Hz, 2 POLES

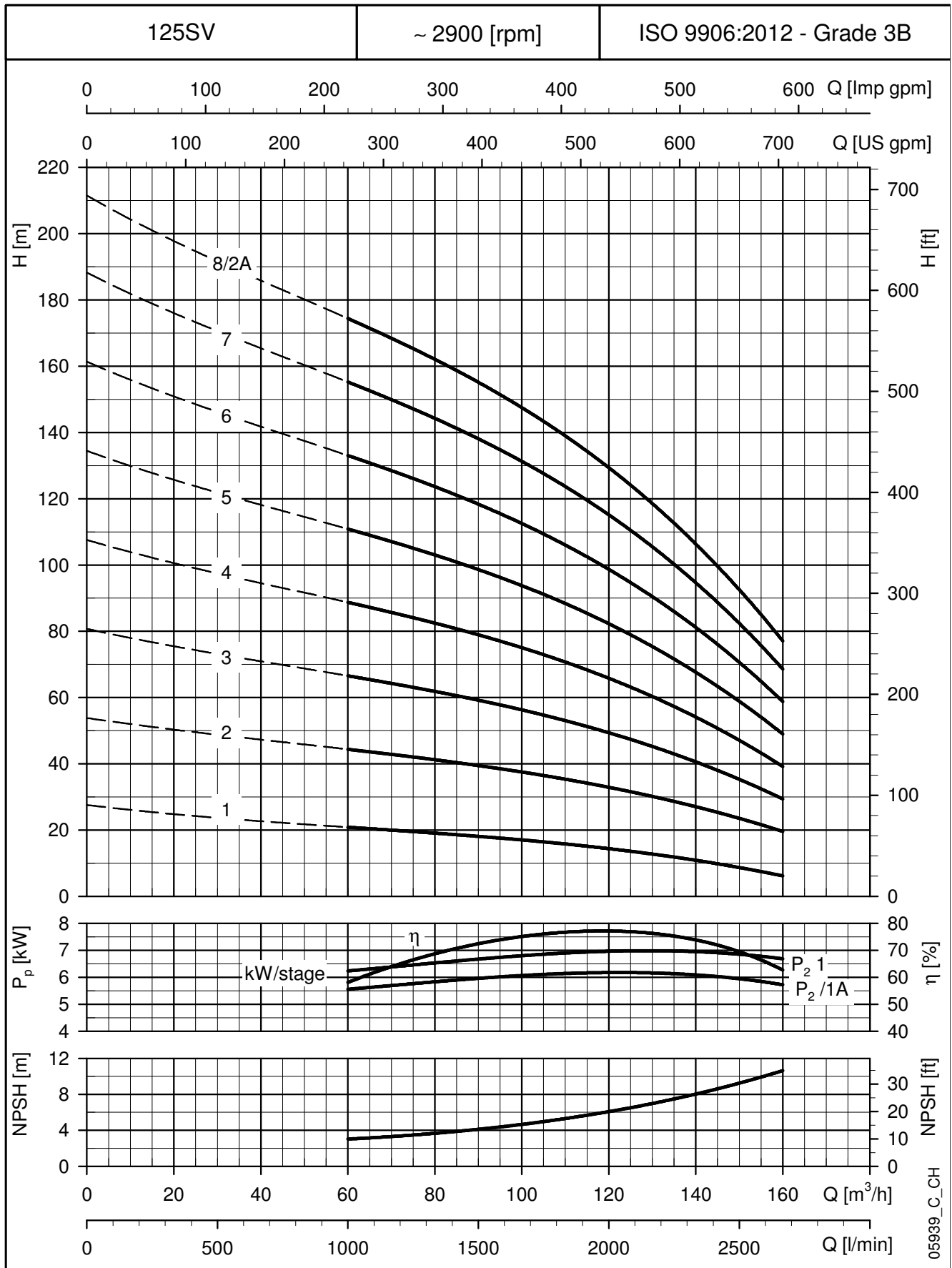

These performances are valid for liquids with density $\rho = 1.0 \text{ Kg/dm}^3$ and kinematic viscosity $\nu = 1 \text{ mm}^2/\text{sec}$.

e-SVH: e-SV with HYDROVAR

e-SVH SERIES e-SV WITH HYDROVAR

Background and context

For all pumping needs in commercial or residential building and in industry applications, the demand for intelligent pumping systems is constantly growing. Controlled systems offer many advantages: reduced operating costs for the lifetime of the pump, lower environmental impact, longer lifetime of piping systems and networks.

For this reason, Lowara has developed the e-SVH: an intelligent pumping system which assures high level performance with energy consumption tailored to the system's demand.

Benefits of e-SVH with HYDROVAR

Saving: e-SVH transforms the e-SV pumps into variable speed intelligent pumping systems. Thanks to the HYDROVAR, the speed of each pump varies so as to maintain a constant flow, a constant pressure, or a differential pressure. In doing so, at any point in time, the pump only receives the energy required. This in turns allows for considerable savings, especially for systems that have varying loads throughout the day.

Easy installation and space-saving: e-SVH saves time and space during installation. The Hydrovar is delivered already mounted on the motor (for models up to 22kW). The hydrovar is kept cool by the motor fan and does not require a control panel. In order to function, only fuses on the supply line are needed (Check your local electrical installation regulations).

Standard motors: e-SVH models are fitted with three-phase standard TEFC motors with insulation class 155 (F) and IE3 efficiency level from 0,75 to 22 kW.

Identification code:

e-SVH models are identified by the letter "H" and the last two characters.

Examples:

3SVH16F015T /2

3SVH16F015T /3

3SVH16F015T /4C

H = with integrated HYDROVAR

/2 = HYDROVAR HVL2.015 1~ 208-240 V (50/60 Hz)

/3 = HYDROVAR HVL3.015 3~ 208-240 V (50/60 Hz)

/4 = HYDROVAR HVL4.015 3~ 380-460 V (50/60 Hz)

Other options:

C = Premium Card.

Key Features of the HYDROVAR

- **No need for additional pressure sensors:**

The e-SVH is fitted with a pressure transmitter or differential pressure transmitters, depending on the application. The pressure sensors(s) are pre-wired. For eSV with round flanges (G and N versions) the sensors can be installed on the pump flanges.

- **No need for special pumps or motors.**

- **e-SVH is already pre-wired.**

- **No need for IN LINE filters.**

HYDROVAR already includes the THDi filter embedded as standard.

- **No need for bypass or safety systems:**

The e-SVH will immediately switch off when demand drops to zero or when it exceeds maximum pump capacity; thus making installation of additional safety devices unnecessary.

- **Anti-condensation device:**

The HYDROVAR is fitted with anti-condensation devices which switch on when the pump is in standby in order to prevent condensation forming in the unit.



e-SVH SERIES e-SV WITH HYDROVAR

The basic function of the HYDROVAR device is to control the pump to meet the system demands.

HYDROVAR performs these functions by:

- 1) Measuring the system pressure or flow via a transmitter mounted on the pump's delivery side.
- 2) Calculating the motor speed to maintain the correct flow or pressure.
- 3) Sending out a signal to the pump to start the motor, increase speed, decrease speed or stop.
- 4) In the case of multiple pump installations, HYDROVAR will automatically provide for the cyclic changeover of the pumps' starting sequence.

In addition to these basic functions, HYDROVAR can perform controls only manageable by the most advanced computerized control systems. Some examples are:

- Stop the pump(s) at zero demand.
- Stop the pump(s) in case of water failure on the suction side (protection against dry running).
- Stop the pump if the required delivery exceeds the pump's capacity (protection against cavitation caused by excessive demand), or automatically switch on the next pump in a multiple series.
- Protect the pump and motor from over-voltage, under-voltage, overload, and earth fault.
- Vary the pump speed: acceleration and deceleration time.
- Compensate for increased flow resistance at high flow rates.
- Conduct automatic tests at set intervals.
- Monitor the converter and motor operating hours.
- Display the energy consumption (kWh).
- Display all functions on an LCD in different languages (Italian, English, French, German, Spanish, Portuguese, Dutch, etc...).
- Send a signal to a remote control system which is proportional to the pressure and frequency.
- Communicate with external control system via Modbus (RS 485 interface) and Bacnet as standard.

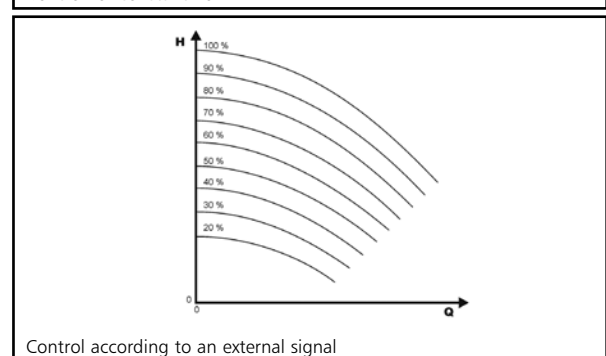
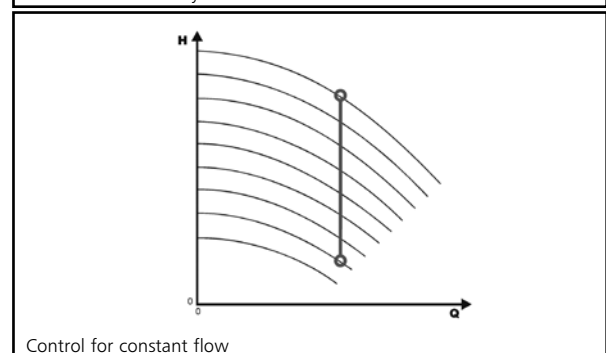
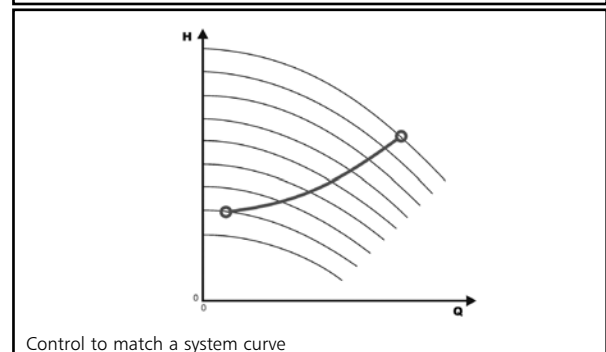
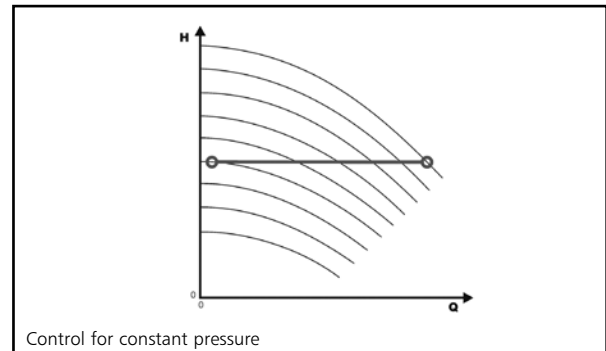

e-SVH SERIES HYDROVAR (ErP 2009/125/EC)

From 1 July 2021 in accordance with the new **Regulations (EU) 2019/1781** and **2021/341** the **variance speed drives** with **three-phase input/output current**, rated voltage between **100 V** and **1000 V**, rated for operating with motors included in the same regulation (**0,12- 1000 kW**), must have efficiency level **IE2**.

The tables below also contain the mandatory information pursuant to Annex I, section 4, of the Regulations.

PN kW	Phase	UNin V	Pa kVA	Power losses (PL) with 10 KHz frequency										IE
				% Pa										
				(% rated speed; % rated torque)										
				stand-by	0;25	0;50	0;100	50;25	50;50	50;100	90;50	90;100		
1,5	~1	208-240		not included in regulation										
2,2														
3														
4														
1,5	~3	208-240	2,45	0,4%	1,3%	1,6%	1,9%	1,4%	1,7%	2,5%	2,0%	3,1%	2	
2,2			3,46	0,3%	1,3%	1,6%	2,4%	1,4%	1,8%	2,7%	2,0%	3,3%		
3			5,15	0,2%	1,1%	1,4%	2,2%	1,3%	1,7%	2,6%	1,9%	3,2%		
4			6,00	0,2%	1,1%	1,3%	2,1%	1,3%	1,6%	2,5%	1,9%	3,1%		
5,5			7,90	0,1%	0,9%	1,1%	1,8%	1,0%	1,4%	2,4%	1,7%	3,2%		
7,5			10,1	0,1%	0,7%	0,9%	1,5%	0,8%	1,1%	2,1%	1,4%	3,1%		
11			15,1	0,1%	0,7%	0,9%	1,7%	0,8%	1,2%	2,3%	1,4%	3,0%		
1,5			380-460	2,56	0,4%	1,2%	1,5%	1,8%	1,3%	1,6%	2,1%	1,6%		2,3%
2,2		3,67		0,3%	1,2%	1,3%	1,7%	1,3%	1,5%	2,1%	1,6%	2,3%		
3		5,00		0,2%	1,1%	1,1%	1,5%	1,2%	1,4%	2,1%	1,5%	2,2%		
4		6,20		0,2%	1,0%	0,9%	1,4%	1,1%	1,4%	2,0%	1,4%	2,2%		
5,5		8,30		0,2%	0,8%	0,8%	1,3%	0,9%	1,2%	1,9%	1,3%	2,2%		
7,5		10,7		0,1%	0,7%	0,6%	1,2%	0,7%	1,0%	1,8%	1,2%	2,3%		
11		15,9		0,1%	0,6%	0,6%	1,2%	0,7%	1,0%	1,8%	1,2%	2,2%		
15		21,5		0,1%	0,5%	0,6%	1,2%	0,6%	0,9%	1,6%	1,1%	2,0%		
18,5		25,6		0,1%	0,5%	0,6%	1,2%	0,6%	0,8%	1,6%	1,0%	1,9%		
22		29,4		0,0%	0,5%	0,7%	1,3%	0,6%	0,9%	1,6%	1,0%	2,1%		

hvl-pl-en_a_te

PN kW	~	UNin V	Manufacturer		f _{Nin} Hz	I _{Nin} max A	U _{nout} V	f _{Nout} Hz	I _{Nin} max A	Operating conditions*									
			Xylem Service Italia Srl Reg. No. 07520560967 Montecchio Maggiore (VI) - Italia							Altitude asl m	T.amb min/max °C	ATEX							
			Model																
1,5	1	208-240	HVL 2.015-...		50/60	11,6	0-100% U _{Nin}	15-70	7,5	≤ 1000	-15/40	No							
2,2			HVL 2.022-...			1			15,1										
3			HVL 2.030-...			22,3			14,3										
4			HVL 2.040-...			27,6			16,7										
1,5	3	208-240	HVL 3.015-...		50/60	7	0-100% U _{Nin}	15-70	7,5	≤ 1000	-15/40	No							
2,2			HVL 3.022-...			9,1			10										
3			HVL 3.030-...			13,3			14,3										
4			HVL 3.040-...			16,5			16,7										
5,5			HVL 3.055-...			23,5			24,2										
7,5			HVL 3.075-...			29,6			31										
11		HVL 3.110-...		3		43,9													
1,5		380-460	380-460	HVL 4.015-...		50/60			3,9				0-100% U _{Nin}	15-70	4,1	≤ 1000	-15/40	No	
2,2				HVL 4.022-...					5,3						5,7				
3				HVL 4.030-...					7,2						7,3				
4	HVL 4.040-...			10,1	10														
5,5	HVL 4.055-...			12,8	13,5														
7,5	HVL 4.075-...			16,9	17														
11	HVL 4.110-...			24,2	24														
15	HVL 4.150-...			33,3	32														
18,5	HVL 4.185-...		38,1	38															
22	HVL 4.220-...		44,7	44															

*up to 2000 meters or maximum 55°C reducing the supplied power

hvl-en_a_te

HYDROVAR HVL IDENTIFICATION CODE

H V L 4 . 0 7 5 - A 0 0 1 0

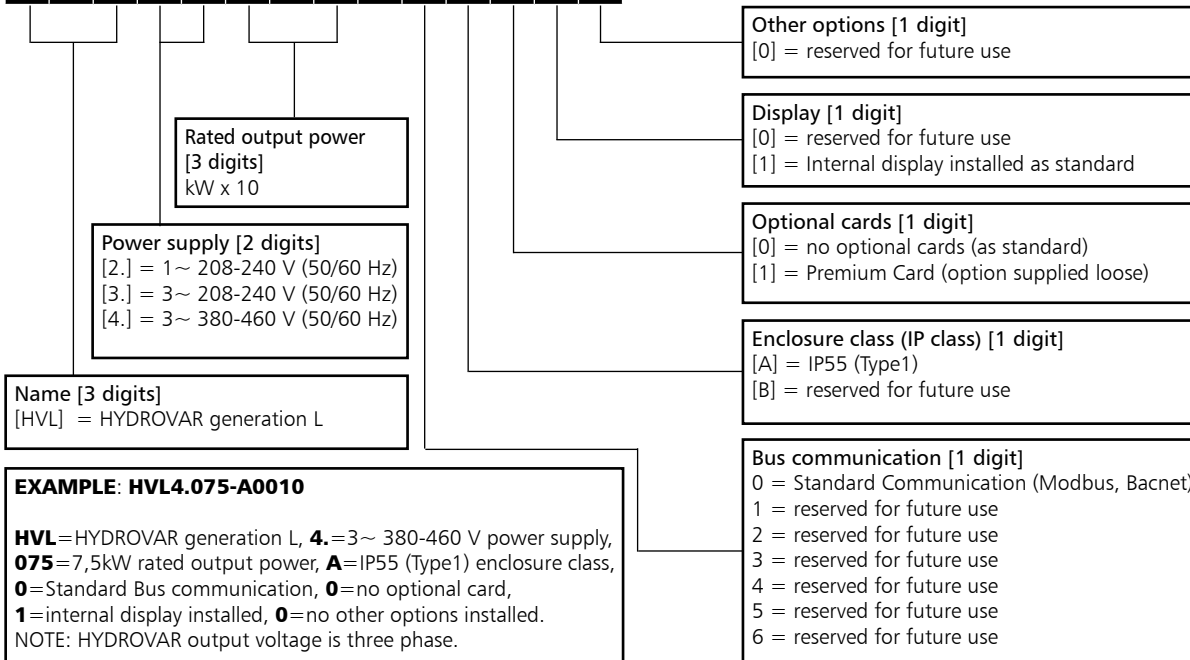

DIMENSIONS AND WEIGHTS



TYPE	MODELS			DIMENSIONS (mm)				WEIGHT Kg
	/2	/3	/4	L	B	H	X	
SIZE A	HVL2.015 ÷ 2.022	HVL3.015 ÷ 3.022	HVL4.015 ÷ 4.040	216	205	170	243	5,6
SIZE B	HVL2.030 ÷ 2.040	HVL3.030 ÷ 3.055	HVL4.055 ÷ 4.110	276	265	185	305	10,5
SIZE C	-	HVL3.075 ÷ 3.110	HVL4.150 ÷ 4.220	366	337	200	407	15,6

HVL_dim-en_b_td

HYDROVAR HVL EMC COMPATIBILITY

EMC requirements

HYDROVAR fulfills the product standard EN61800-3:2004 + A1:2012, which defines categories (C1 to C4) for device application areas.

Depending on the motor cable length, a classification of HYDROVAR by category (based on EN61800-3) is reported in the following tables:

HVL	HYDROVAR classification by categories based on EN61800-3
2.015 ÷ 2.040	C1 (*)
3.015 ÷ 3.110	C2 (*)
4.015 ÷ 4.220	C2 (*)

(*) 0,75 motor cable length; contact Xylem for further information

En-Rev_A

CARD

Premium Card HYDROVAR (optional)

For the e-SVH series, the Premium Card comes fitted as option on the standalone HYDROVAR.

This allows to control up to five fix speed pumps via an external panel.

The Premium Card will allow additional features listed below:

- 2 additional Analog Inputs
- 2 Analog Outputs
- 1 additional digital input
- 5 relays.



OPTIONAL COMPONENTS

Sensors

The following sensors are available for HYDROVAR:

- a. Pressure-transducer
- b. Differential pressure-transducer
- c. Temperature-sensor
- d. Flow indicator (orifice plate, inductive flow meter)
- e. Level-sensor.

HYDROVAR HVL (WALL MOUNTING KIT) DIMENSIONS AND WEIGHTS

As an option a HYDROVAR wall mounting kit is also available. This is used where mounting on the pump unit is impossible or where you would like the controls in another location. These are available for the new generation HYDROVAR HVL 2.015-4.220 (22 kW). The speed of the cooling fan modulates with the HYDROVAR usage which optimizes energy consumption and also reduces noise.

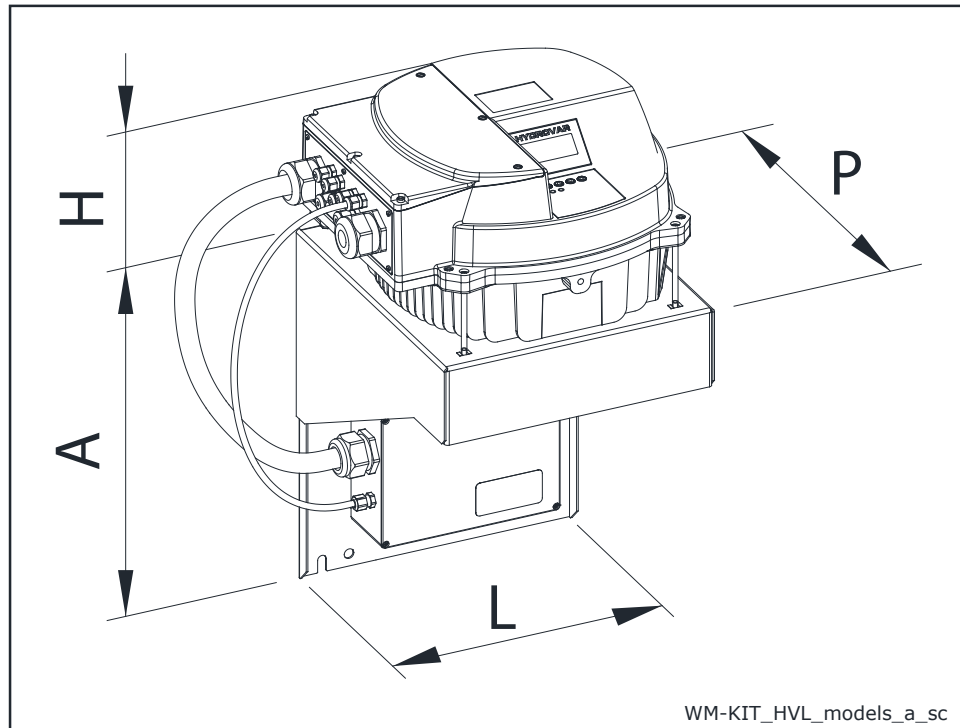

WM KIT TYPE	kW	WM KIT POWER SUPPLY	HVL SIZE	DIMENSIONS (mm)				WEIGHT (kg)	
				A	H	L	P	HVL	WM KIT
WM KIT HVL 2.015	1,5	1~ 230V	A	220	170	202	232	5,6	2,6
WM KIT HVL 2.022	2,2			220	170	202	232	5,6	2,6
WM KIT HVL 2.030	3		B	240	175	258	290	10,5	8,2
WM KIT HVL 2.040	4			320	175	288	305	10,5	5,4
WM KIT HVL 3.015	1,5	3~ 230V	A	220	170	202	232	5,6	2,6
WM KIT HVL 3.022	2,2			220	170	202	232	5,6	2,6
WM KIT HVL 3.030	3		B	240	175	258	290	10,5	8,2
WM KIT HVL 3.040	4			240	175	258	290	10,5	8,2
WM KIT HVL 3.055	5,5		C	240	175	258	290	10,5	8,2
WM KIT HVL 3.075	7,5			400	200	325	365	15,6	11,6
WM KIT HVL 3.110	11		400	200	325	365	15,6	11,6	
WM KIT HVL 4.015	1,5		3~ 400V	A	240	170	258	290	5,6
WM KIT HVL 4.022	2,2	240			170	258	290	5,6	8,2
WM KIT HVL 4.030	3	240			170	258	290	5,6	8,2
WM KIT HVL 4.040	4	240			170	258	290	5,6	8,2
WM KIT HVL 4.055	5,5	B		240	175	258	290	10,5	8,2
WM KIT HVL 4.075	7,5			240	175	258	290	10,5	8,2
WM KIT HVL 4.110	11	C		320	175	288	305	10,5	5,4
WM KIT HVL 4.150	15			400	200	325	365	15,6	11,6
WM KIT HVL 4.185	18,5			400	200	325	365	15,6	11,6
WM KIT HVL 4.220	22			400	200	325	365	15,6	11,6

WM-KIT_HVL_models-EN_b_td

G/SVH KIT TABLE OF SIZES AND COMPONENTS

e-SVH series electric pump with hydraulic kit and G/SVH accessories, to realise a single-pump booster set which is quick and easy to install. The hydraulic kit can be combined with the following e-SVH electric pumps:

- F versions (in-line ports, round flanges)
- R versions (overlapping ports, round flanges)
- N versions (in-line ports round flanges)
- G versions (in-line ports round flanges)

Assembly instructions inside the kit pack.

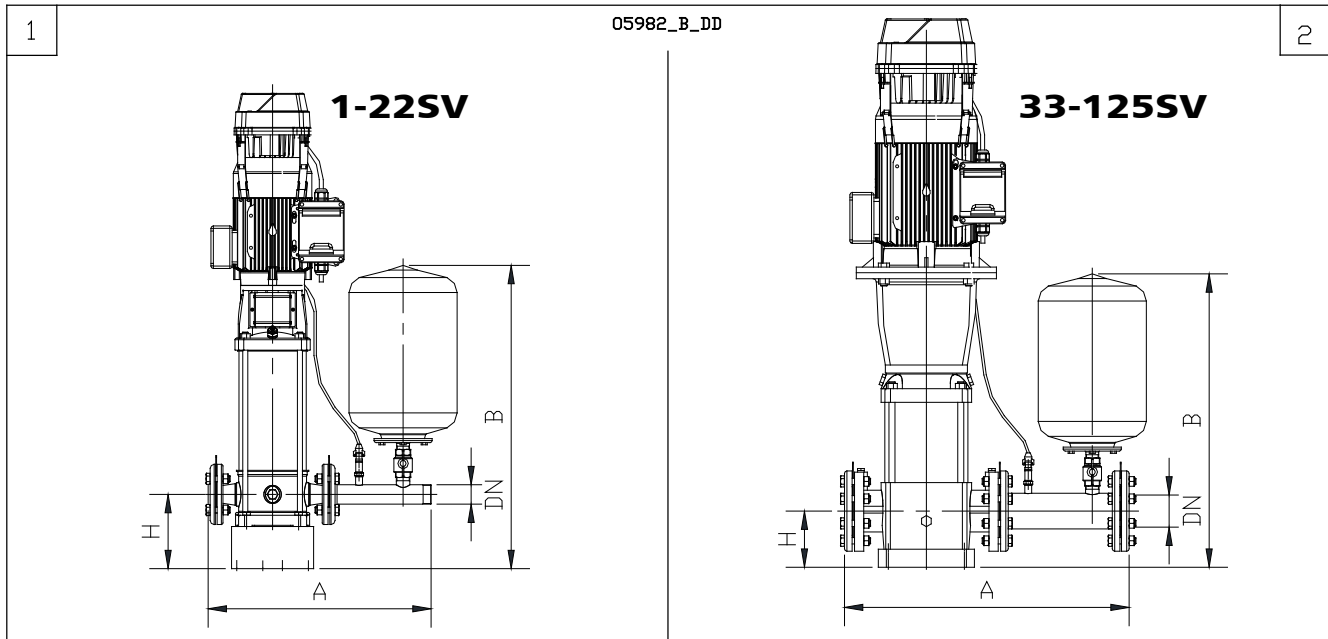

TYPE	PUMP	DRW. N°	DIMENSIONS (mm)				
			DN	PN	H	A	B
G/SVH DN25 PN25	1SV - 3SV	1	25	25	180	524	744
G/SVH DN32 PN25	5SV	1	32	25	180	521	748
G/SVH DN40 PN25	10SV	1	40	25	185	557	756
G/SVH DN50 PN25	15SV - 22SV	1	50	25	195	637	772
G/SVH DN65 PN16	33SV	2	65	16	105	662	690
G/SVH DN65 PN25	33SV	2	65	25	105	674	690
G/SVH DN80 PN16	46SV	2	80	16	140	711	732
G/SVH DN80 PN25	46SV	2	80	25	140	723	732
G/SVH DN100 PN16	66SV - 92SV	2	100	16	140	744	744
G/SVH DN100 PN25	66SV - 92SV	2	100	25	140	744	744
G/SVH DN125 PN16	125SV	2	125	16	160	777	777
G/SVH DN125 PN25	125SV	2	125	25	160	777	777

Same dimensions for STANDARD, A304 and A316 versions.

g-sv-2p50-en_b_td

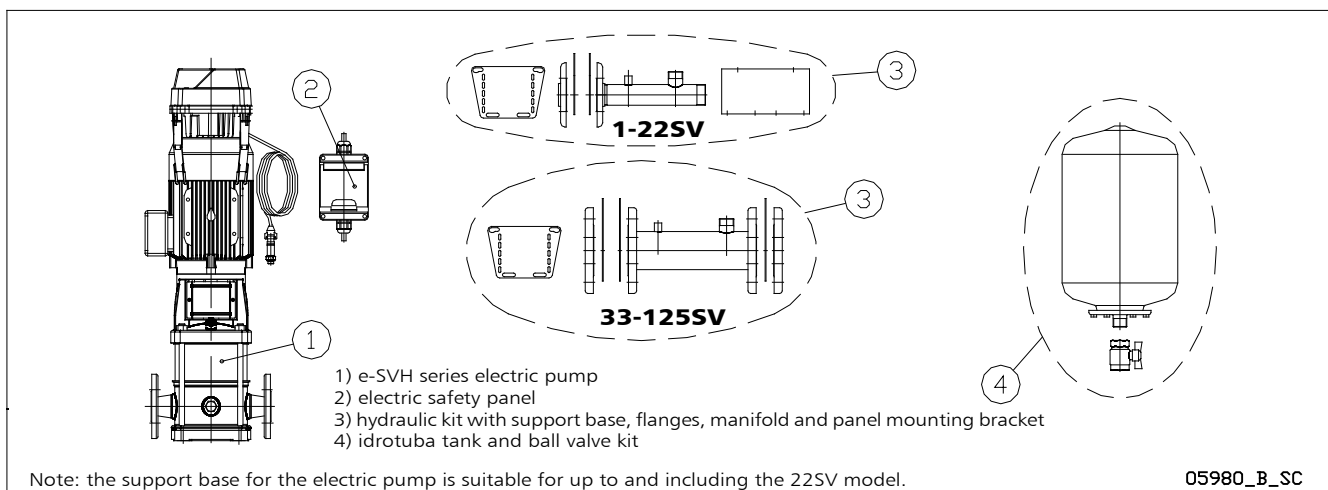

Note: the support base for the electric pump is suitable for up to and including the 22SV model.

05980_B_SC

e-SVH SERIES
LIST OF MODELS AT 50 Hz, 2 POLES

PUMP TYPE	kW	VERSION		
		/2	/3	/4
		1 ~ 230V	3 ~ 230V	3 ~ 400V
1SVH15	0,75	A	A	A
1SVH22	1,1	A	A	A
1SVH30	1,5	A	A	A
1SVH37	2,2	A	A	A
3SVH08	0,75	A	A	A
3SVH12	1,1	A	A	A
3SVH16	1,5	A	A	A
3SVH21	2,2	A	A	A
3SVH25	2,2	A	A	A
3SVH29	3	B	B	A
3SVH33	3	B	B	A
5SVH05	0,75	A	A	A
5SVH08	1,1	A	A	A
5SVH11	1,5	A	A	A
5SVH14	2,2	A	A	A
5SVH16	2,2	A	A	A
5SVH21	3	B	B	A
5SVH28	4	B	B	A
5SVH33	5,5	-	B	B
10SVH04	1,5	A	A	A
10SVH06	2,2	A	A	A
10SVH08	3	B	B	A
10SVH11	4	B	B	A
10SVH15	5,5	-	B	B
10SVH20	7,5	-	C	B
10SVH21	11	-	C	B
15SVH02	2,2	A	A	A
15SVH03	3	B	B	A
15SVH05	4	B	B	A
15SVH07	5,5	-	B	B
15SVH09	7,5	-	C	B
15SVH13	11	-	C	B
15SVH17	15	-	-	C
22SVH01	1,1	A	A	A
22SVH03	3	B	B	A
22SVH04	4	B	B	A
22SVH05	5,5	-	B	B
22SVH07	7,5	-	C	B
22SVH10	11	-	C	B
22SVH14	15	-	-	C
22SVH17	18,5	-	-	C

PUMP TYPE	kW	VERSION		
		/2	/3	/4
		1 ~ 230V	3 ~ 230V	3 ~ 400V
33SVH1	3	B	B	A
33SVH2	5,5	-	B	B
33SVH3	7,5	-	C	B
33SVH4	11	-	C	B
33SVH5	15	-	-	C
33SVH6	15	-	-	C
33SVH7	18,5	-	-	C
46SVH1	4	B	B	A
46SVH2	7,5	-	C	B
46SVH3	11	-	C	B
46SVH4	15	-	-	C
46SVH6	22	-	-	C
66SVH1	5,5	-	B	B
66SVH2	11	-	C	B
66SVH3	18,5	-	-	C
66SVH4	22	-	-	C
92SVH1	7,5	-	C	B
92SVH2	15	-	-	C
92SVH3	22	-	-	C
125SVH1	7,5	-	C	B
125SVH2	15	-	-	C
125SVH3	22	-	-	C

LEGEND

SVH-HVL_models-2p50-en_c_sc

A, B, C : are the mechanical size of HYDROVAR, refer to "HYDROVAR DIMENSIONS AND WEIGHTS" table in previous pages.

e-SVH SERIES

ELECTRICAL DATA TABLE AT 50 Hz, 2 POLES

PUMP TYPE	kW	MEI ≥ (1)	INPUT CURRENT (2) (A)		
			/2	/3	/4
			1 ~ 230V	3 ~ 230V	3 ~ 400V
1SVH15	0,75	0,7	4,0	2,4	1,4
1SVH22	1,1	0,7	5,8	3,5	2,1
1SVH30	1,5	0,7	8,0	4,8	2,8
1SVH37	2,2	0,7	11,7	7,1	4,1
3SVH08	0,75	0,7	4,0	2,4	1,4
3SVH12	1,1	0,7	5,8	3,5	2,1
3SVH16	1,5	0,7	8,0	4,8	2,8
3SVH21	2,2	0,7	11,7	7,1	4,1
3SVH25	2,2	0,7	11,7	7,1	4,1
3SVH29	3	0,7	15,9	9,6	5,6
3SVH33	3	0,7	15,9	9,6	5,6
5SVH05	0,75	0,7	4,0	2,4	1,4
5SVH08	1,1	0,7	5,8	3,5	2,1
5SVH11	1,5	0,7	8,0	4,8	2,8
5SVH14	2,2	0,7	11,7	7,1	4,1
5SVH16	2,2	0,7	11,7	7,1	4,1
5SVH21	3	0,7	15,9	9,6	5,6
5SVH28	4	0,7	21,2	12,6	7,3
5SVH33	5,5	0,7	-	17,3	10,1
10SVH04	1,5	0,7	8,0	4,8	2,8
10SVH06	2,2	0,7	11,7	7,1	4,1
10SVH08	3	0,7	15,9	9,6	5,6
10SVH11	4	0,7	21,2	12,6	7,3
10SVH15	5,5	0,7	-	17,3	10,1
10SVH20	7,5	0,7	-	23,1	13,7
10SVH21	11	0,7	-	34,0	19,4
15SVH02	2,2	0,7	11,7	7,1	4,1
15SVH03	3	0,7	15,9	9,6	5,6
15SVH05	4	0,7	21,2	12,6	7,3
15SVH07	5,5	0,7	-	17,3	10,1
15SVH09	7,5	0,7	-	23,1	13,7
15SVH13	11	0,7	-	34,0	19,4
15SVH17	15	0,7	-	-	26,1
22SVH01	1,1	0,7	5,8	3,5	2,1
22SVH03	3	0,7	15,9	9,6	5,6
22SVH04	4	0,7	21,2	12,6	7,3
22SVH05	5,5	0,7	-	17,3	10,1
22SVH07	7,5	0,7	-	23,1	13,7
22SVH10	11	0,7	-	34,0	19,4
22SVH14	15	0,7	-	-	26,1
22SVH17	18,5	0,7	-	-	32,1

PUMP TYPE	kW	MEI ≥ (1)	INPUT CURRENT (2) (A)		
			/2	/3	/4
			1 ~ 230V	3 ~ 230V	3 ~ 400V
33SVH1	3	0,7	15,9	9,6	5,6
33SVH2	5,5	0,7	-	17,3	10,1
33SVH3	7,5	0,7	-	23,1	13,7
33SVH4	11	0,7	-	34,0	19,4
33SVH5	15	0,7	-	-	26,1
33SVH6	15	0,7	-	-	26,1
33SVH7	18,5	0,7	-	-	32,1
46SVH1	4	0,7	21,2	12,6	7,3
46SVH2	7,5	0,7	-	23,1	13,7
46SVH3	11	0,7	-	34,0	19,4
46SVH4	15	0,7	-	-	26,1
46SVH6	22	0,7	-	-	38,1
66SVH1	5,5	0,7	-	17,3	10,1
66SVH2	11	0,7	-	34,0	19,4
66SVH3	18,5	0,7	-	-	32,1
66SVH4	22	0,7	-	-	38,1
92SVH1	7,5	0,6	-	23,1	13,7
92SVH2	15	0,6	-	-	26,1
92SVH3	22	0,6	-	-	38,1
125SVH1	7,5	-	-	23,1	13,7
125SVH2	15	-	-	-	26,1
125SVH3	22	-	-	-	38,1

SVH-HVL-2p50-en_b_te

Q = DELIVERY	Pp = POWER
H = HEAD	np = EFFICIENCY
(1) Values referred to operation at 2900 min ⁻¹ (50 Hz).	
(2) Nominal values referred to operation at 2900 min ⁻¹ (50 Hz).	

1, 3, 5, 10, 15, 22SV Value referred to versions F, T, R, N, V, C, K. P version excluded.

33, 46SV Value referred to the G and N versions with PN ≤ 25 bar (2500 kPa). G and N versions with PN > 25 bar (2500 kPa) and P version excluded.

66, 92, 125SV Value referred to the G, N versions. P version excluded.

1, 3, 5, 10, 15, 22SVH SERIES HYDRAULIC PERFORMANCE TABLE AT 50 Hz, 2 POLES

PUMP TYPE	RATED POWER		Q = DELIVERY														
			l/min	12	20	25	30	35	40	45	50	60	73	100	120	141	
			0	0,7	1,2	1,5	1,8	2,1	2,4	2,7	3,0	3,6	4,4	6,0	7,2	8,5	
		m ³ /h	H = TOTAL HEAD IN METRES OF COLUMN OF WATER														
kW	HP																
1SVH15	0,75	1	90,9	90,5	85,6	79,3	70,1	58,1	43,1								
1SVH22	1,1	1,5	134,6	134,1	127,4	118,1	104,4	86,1	63,5								
1SVH30	1,5	2	181,7	181,3	172,6	160,1	141,2	115,7	83,9								
1SVH37	2,2	3	225,9	224,9	216,1	201,9	179,3	148,1	108,7								
3SVH08	0,75	1	60,0		59,1	58,2	57,0	55,4	53,4	51,0	48,1	40,7	27,5				
3SVH12	1,1	1,5	89,6		87,8	86,4	84,5	82,1	79,1	75,5	71,1	59,9	40,1				
3SVH16	1,5	2	119,9		117,8	116,1	113,6	110,5	106,5	101,6	95,8	80,9	54,2				
3SVH21	2,2	3	159,3		156,9	154,6	151,4	147,3	142,1	135,7	128,0	108,5	73,6				
3SVH25	2,2	3	188,5		186,1	183,3	179,3	174,1	167,6	159,7	150,3	126,6	84,8				
3SVH29	3	4	219,3		216,0	212,8	208,3	202,6	195,3	186,4	175,7	148,6	100,2				
3SVH33	3	4	248,5		245,3	241,5	236,2	229,3	220,7	210,2	197,7	166,3	111,2				
5SVH05	0,75	1	38,0						36,4	36,0	35,5	34,5	32,9	28,2	23,5	17,1	
5SVH08	1,1	1,5	60,1						57,6	57,0	56,2	54,6	51,8	44,1	36,2	25,8	
5SVH11	1,5	2	82,8						79,3	78,4	77,5	75,2	71,4	60,7	49,9	35,6	
5SVH14	2,2	3	105,7						102,0	100,9	99,6	96,6	91,7	77,8	64,0	46,3	
5SVH16	2,2	3	120,5						115,9	114,6	113,1	109,6	103,9	87,8	72,1	51,8	
5SVH21	3	4	157,9						152,0	150,3	148,3	143,6	136,1	114,9	94,2	67,6	
5SVH28	4	5,5	211,5						204,2	201,9	199,4	193,3	183,4	155,5	128,0	92,7	
5SVH33	5,5	7,5	249,2						241,0	238,4	235,5	228,4	216,9	184,2	151,9	110,3	

Hydraulic performances in compliance with ISO 9906:2012 - Grade 3B (ex ISO 9906:1999 - Annex A).

1-5svh-2p50-en_c_th

PUMP TYPE	RATED POWER		Q = DELIVERY														
			l/min	83,34	100	133	170	183,34	233	270	330	350	400	430	460	483,33	
			0	5,0	6,0	8,0	10,2	11,0	14,0	16,2	19,8	21,0	24,0	25,8	27,6	29,0	
		m ³ /h	H = TOTAL HEAD IN METRES OF COLUMN OF WATER														
kW	HP																
10SVH04	1,5	2	47,7	44,2	43,0	39,9	34,8	32,6	21,7								
10SVH06	2,2	3	71,8	66,8	65,0	60,4	53,1	49,8	33,9								
10SVH08	3	4	95,3	88,9	86,5	80,1	70,2	65,7	44,5								
10SVH11	4	5,5	129,6	121,3	118,1	109,6	96,3	90,3	62,1								
10SVH15	5,5	7,5	179,5	167,9	163,4	151,6	132,8	124,3	83,9								
10SVH20	7,5	10	240,6	226,0	220,3	205,0	180,2	168,9	114,3								
10SVH21	11	15	253,6	241,0	235,5	220,2	195,0	183,5	127,5								
15SVH02	2,2	3	28,7			26,7	25,9	25,5	23,9	22,4	18,9	17,4	13,1				
15SVH03	3	4	43,3			40,4	39,1	38,6	36,2	33,8	28,7	26,5	20,1				
15SVH05	4	5,5	72,7			67,8	65,8	65,0	61,0	57,1	48,7	45,2	34,9				
15SVH07	5,5	7,5	101,9			94,5	91,9	90,8	85,7	80,6	69,4	64,7	50,5				
15SVH09	7,5	10	131,9			124,4	121,0	119,6	112,8	106,1	91,5	85,5	67,4				
15SVH13	11	15	191,3			179,2	174,5	172,5	163,1	153,7	133,1	124,5	98,6				
15SVH17	15	20	251,6			237,3	231,4	228,9	216,9	205,0	178,4	167,3	133,6				
22SVH01	1,1	1,5	14,7					13,5	12,7	12,0	10,4	9,7	7,7	6,3	4,7	3,4	
22SVH03	3	4	45,4					42,2	40,4	38,5	34,5	32,8	27,8	24,2	20,2	16,6	
22SVH04	4	5,5	60,9					56,8	54,4	51,9	46,6	44,4	37,9	33,1	27,7	23,0	
22SVH05	5,5	7,5	76,0					70,9	67,9	64,9	58,3	55,6	47,4	41,4	34,7	28,8	
22SVH07	7,5	10	108,5					103,1	99,4	95,7	87,2	83,7	73,1	65,3	56,5	48,8	
22SVH10	11	15	155,4					148,2	143,1	137,8	125,9	120,9	105,8	94,8	82,3	71,3	
22SVH14	15	20	216,6					207,7	200,9	193,7	177,4	170,4	149,4	133,9	116,1	100,6	
22SVH17	18,5	25	263,5					252,8	244,7	236,0	216,2	207,8	182,3	163,6	142,0	123,2	

Hydraulic performances in compliance with ISO 9906:2012 - Grade 3B (ex ISO 9906:1999 - Annex A).

10-22svh-2p50-en_c_th

33, 46, 66, 92, 125SVH SERIES

HYDRAULIC PERFORMANCE TABLE AT 50 Hz, 2 POLES

PUMP TYPE	RATED POWER		Q = DELIVERY										
			l/min 0	250	300	367	417	500	583	667	750	900	1000
	kW	HP	m ³ /h 0	15	18	22	25	30	35	40	45	54	60
H = TOTAL HEAD METRES COLUMN OF WATER													
33SVH1	3	4	23,8	21,7	21,2	20	20	17,8	15,5	12,7			
33SVH2	5,5	7,5	47,8	45	44,1	43	41	39	35	29,9			
33SVH3	7,5	10	71,5	67,4	66,0	64	62	58	52,0	44,6			
33SVH4	11	15	95,9	91,1	90	87	85	80	73	63,1			
33SVH5	15	20	120,4	114,9	113	110	107	101	92	80,5			
33SVH6	15	20	145,6	139	137	133	129	121	110	96,1			
33SVH7	18,5	25	170,3	162,8	160	156	152	142	130	113,3			
46SVH1	4	5,5	27,2			24	23,5	22,5	21,4	19,9	18,2	14,3	10,8
46SVH2	7,5	10	52,6			48,5	47,7	46,1	44,2	41,7	38,7	31,4	25,1
46SVH3	11	15	80,8			74,3	73	71	68	65	60	50	40,7
46SVH4	15	20	107,3			99,8	98	96	92	87	82	68	55,9
46SVH6	22	30	161			149,9	148	144	139	132	124	104	86

Hydraulic performances in compliance with ISO 9906:2012 - Grade 3B (ex ISO 9906:1999 - Annex A).

33-46svh-2p50-en_b_th

PUMP TYPE	RATED POWER		Q = DELIVERY												
			l/min 0	500	600	700	750	900	1000	1200	1300	1417	1600	1800	2000
	kW	HP	m ³ /h 0	30	36	42	45	54	60	72	78	85	96	108	120
H = TOTAL HEAD METRES COLUMN OF WATER															
66SVH1	5,5	7,5	29,2	25,8	24,8	23,8	23,3	21,8	20,7	17,9	16,1	13,5			
66SVH2	11	15	60,4	55,7	54,4	52,8	52	49,3	47,1	42	38,9	34,7			
66SVH3	18,5	25	91,4	84,7	83	81	79	75	72	64	60	53,5			
66SVH4	22	30	121,6	112,5	110	107	105	100	96	86	79	70,8			
92SVH1	7,5	10	33,5				28,7	27,2	26,2	24,3	23,3	22,2	20,2	17,6	14,3
92SVH2	15	20	67,8				58,2	55	53	49,5	47,6	45,2	41,4	36,3	29,6
92SVH3	22	30	102,2				88,2	84	81	76	73	69	63	56	46,3

Hydraulic performances in compliance with ISO 9906:2012 - Grade 3B (ex ISO 9906:1999 - Annex A).

66-92svh-2p50-en_b_th

PUMP TYPE	RATED POWER		Q = DELIVERY													
			l/min 0	500	600	750	900	1000	1200	1416	1700	1900	2000	2150	2300	2666
	kW	HP	m ³ /h 0	30	36	45	54	60	72	84,96	102	114	120	129	138	160
H = TOTAL HEAD METRES COLUMN OF WATER																
125SVH1	7,5	10	27,6					20,8	19,8	18,6	16,8	15,3	14,4	12,9	11,3	6,2
125SVH2	15	20	53,8					44,4	43	40	37,1	34,4	32,9	30,4	27,7	19,6
125SVH3	22	30	80,7					66,5	64	61	56	52	49	46	42	29,4

Hydraulic performances in compliance with ISO 9906:2012 - Grade 3B (ex ISO 9906:1999 - Annex A).

125svh-2p50-en_a_th

1SVH SERIES

DIMENSIONS AND WEIGHTS AT 50 Hz, 2 POLES

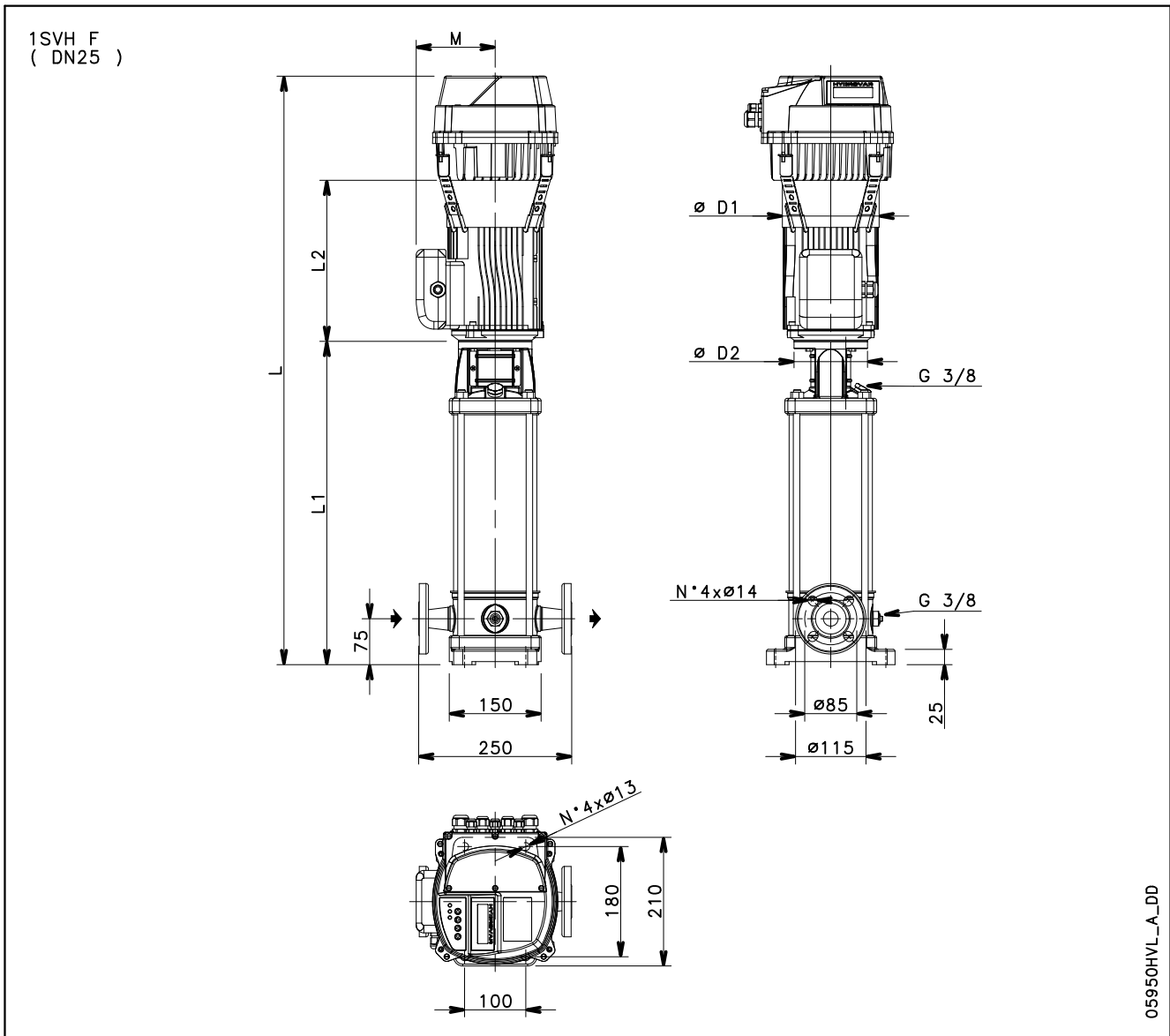

05950HVL_A_DD

PUMP TYPE	MOTOR		DIMENSIONS (mm)					L			WEIGHT (kg)		
			L1	L2	M	D1	D2	/2	/3	/4	/2	/3	/4
				3 ~	3 ~	3 ~		1 ~ 230V	3 ~ 230V	3 ~ 400V	1 ~ 230V	3 ~ 230V	3 ~ 400V
1SVH15	0,75	80	528	263	129	155	120	961	961	961	29,1	29,1	29,1
1SVH22	1,1	80	668	263	129	155	120	1101	1101	1101	34,2	34,2	34,2
1SVH30	1,5	90	838	263	129	155	140	1271	1271	1271	39,6	39,6	39,6
1SVH37	2,2	90	978	298	134	174	140	1446	1446	1446	45,4	45,4	45,4

1SVH SERIES

OPERATING CHARACTERISTICS AT 30..50 Hz

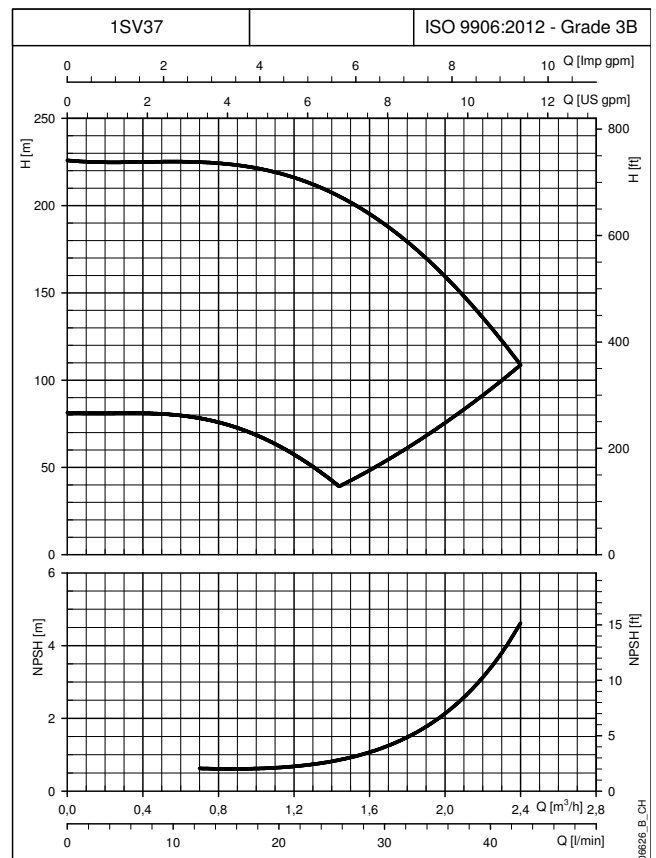
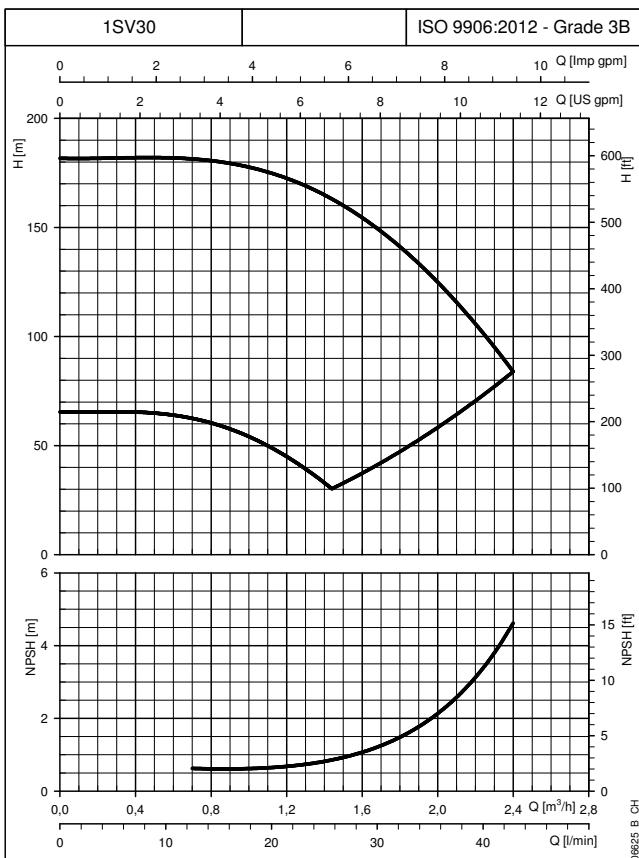
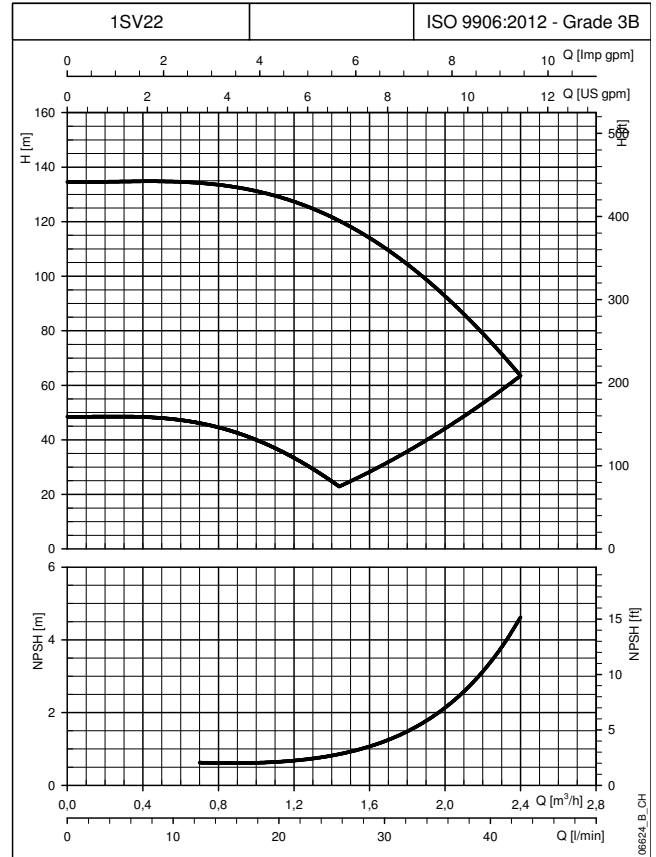
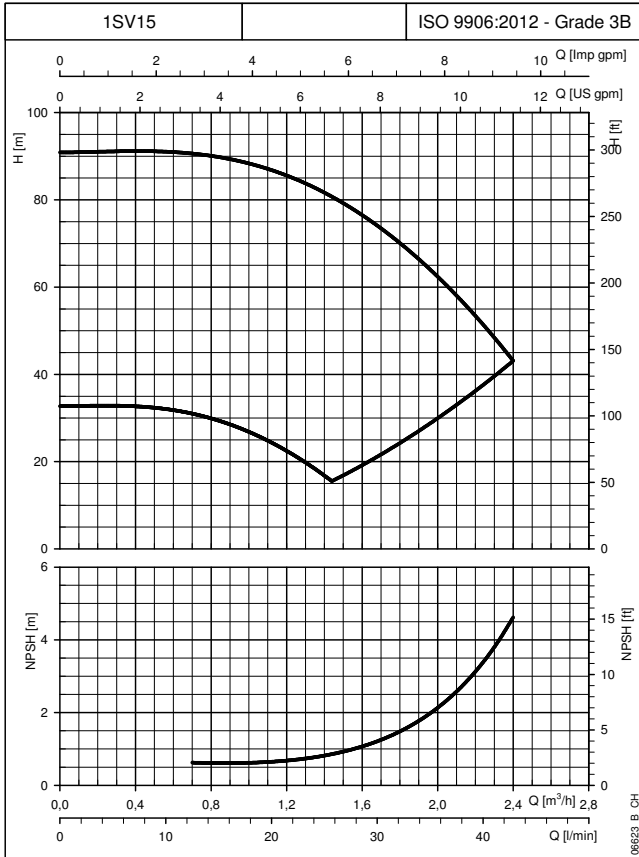

The curves show the performance with one pump running to the minimum and maximum speed. These performances are valid for liquids with density $\rho = 1.0 \text{ Kg/dm}^3$ and kinematic viscosity $\nu = 1 \text{ mm}^2/\text{s}$.

3SVH SERIES DIMENSIONS AND WEIGHTS AT 50 Hz, 2 POLES

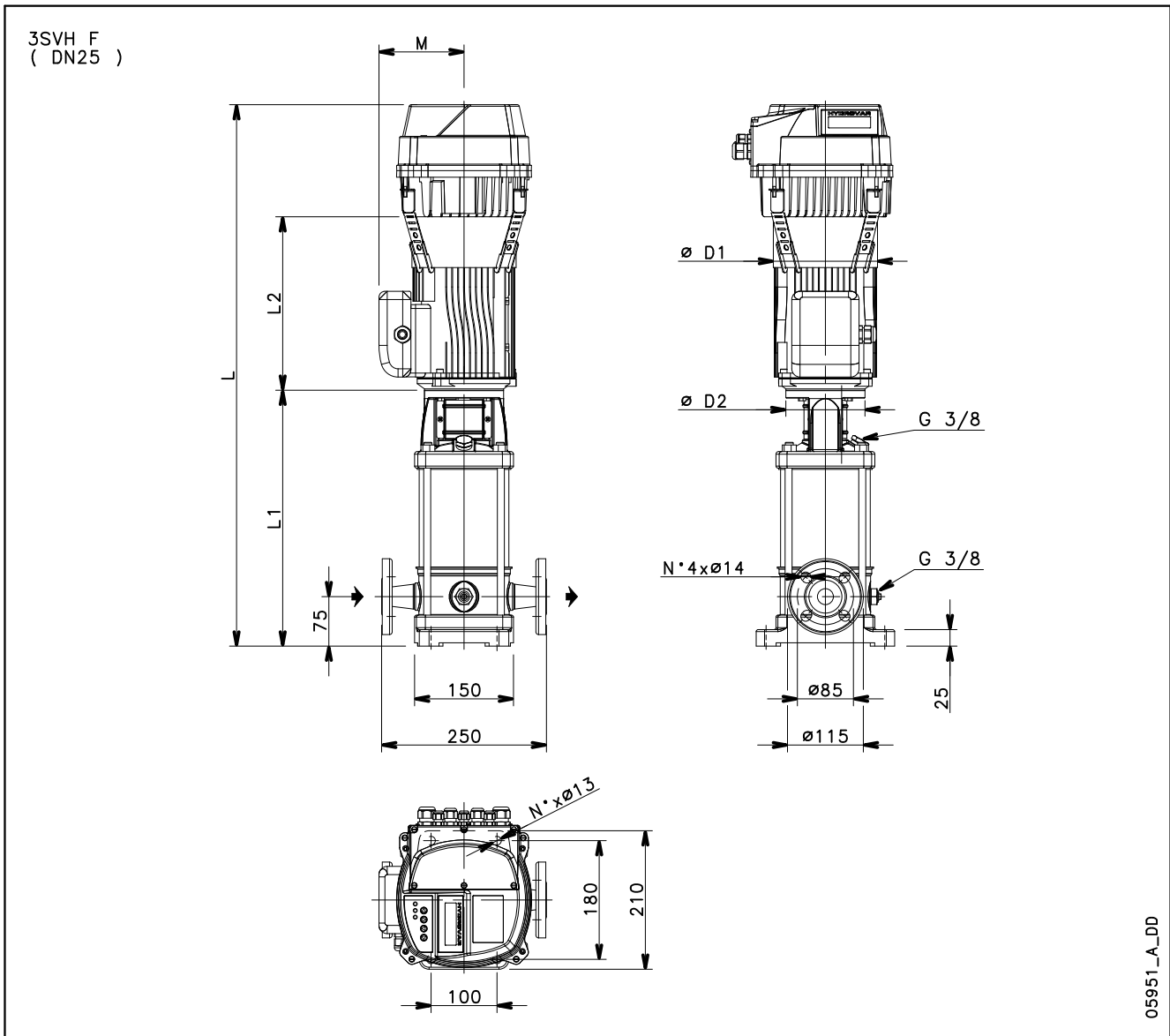

PUMP TYPE	MOTOR		DIMENSIONS (mm)					L			WEIGHT (kg)		
			L1	L2	M	D1	D2	/2	/3	/4	/2	/3	/4
								1 ~ 230V	3 ~ 230V	3 ~ 400V	1 ~ 230V	3 ~ 230V	3 ~ 400V
3SVH08	0,75	80	388	263	129	155	120	821	821	821	26,5	26,5	26,5
3SVH12	1,1	80	468	263	129	155	120	901	901	901	30,3	30,3	30,3
3SVH16	1,5	90	558	263	129	155	140	991	991	991	33,8	33,8	33,8
3SVH21	2,2	90	658	298	134	174	140	1126	1126	1126	40,8	40,8	40,8
3SVH25	2,2	90	738	298	134	174	140	1206	1206	1206	42,4	42,4	42,4
3SVH29	3	100	828	298	134	174	160	1311	1311	1296	53,9	53,9	49,0
3SVH33	3	100	908	298	134	174	160	1391	1391	1376	55,5	55,5	50,6

3SVH SERIES OPERATING CHARACTERISTICS AT 30..50 Hz

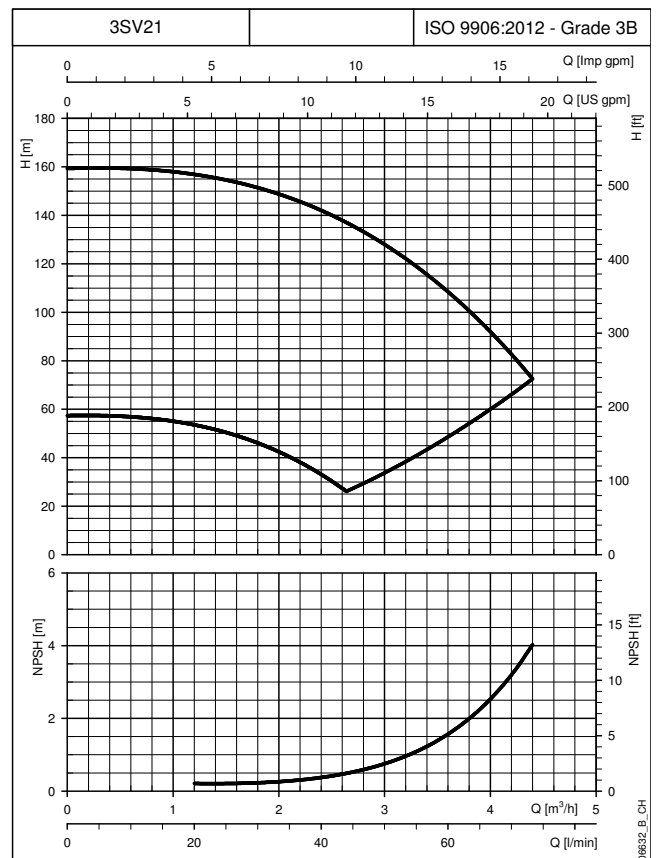
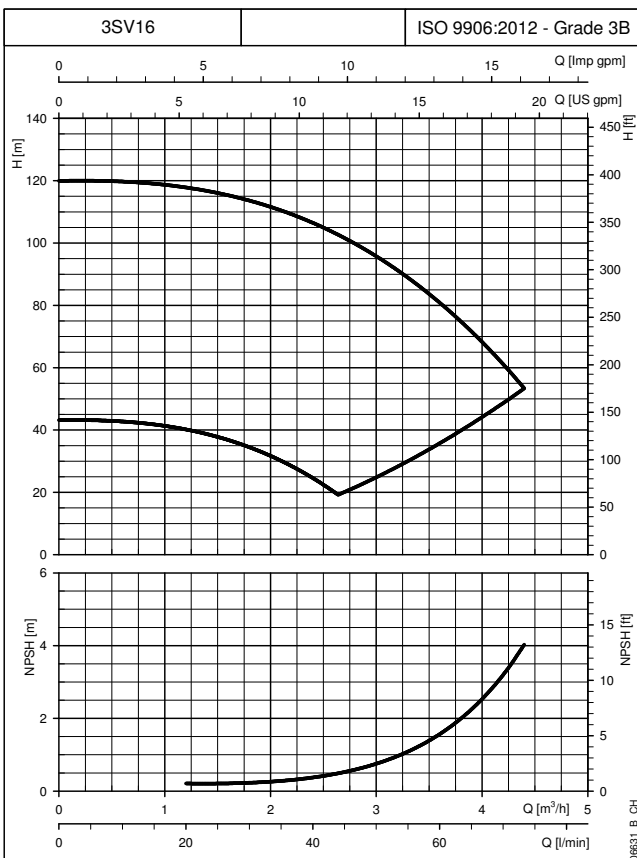
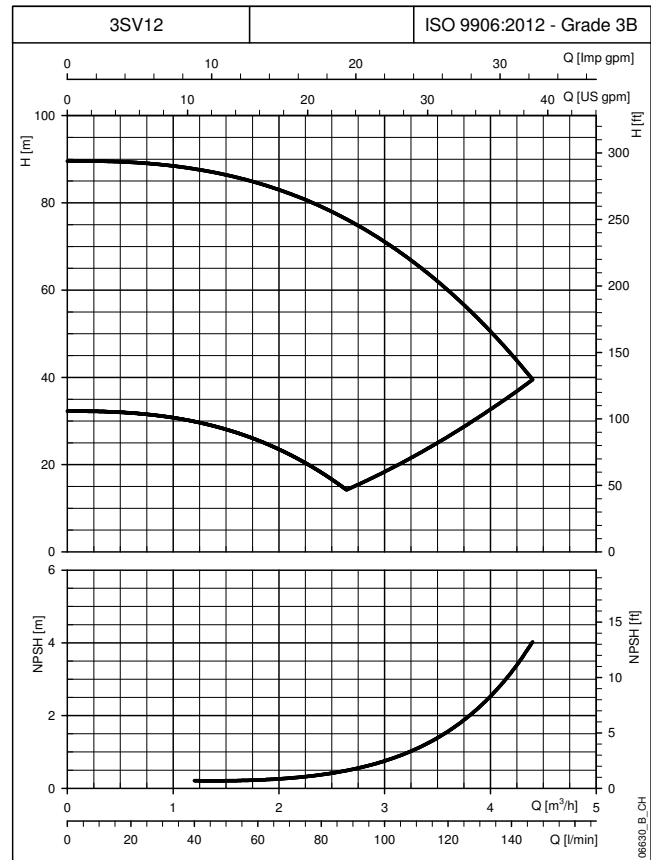
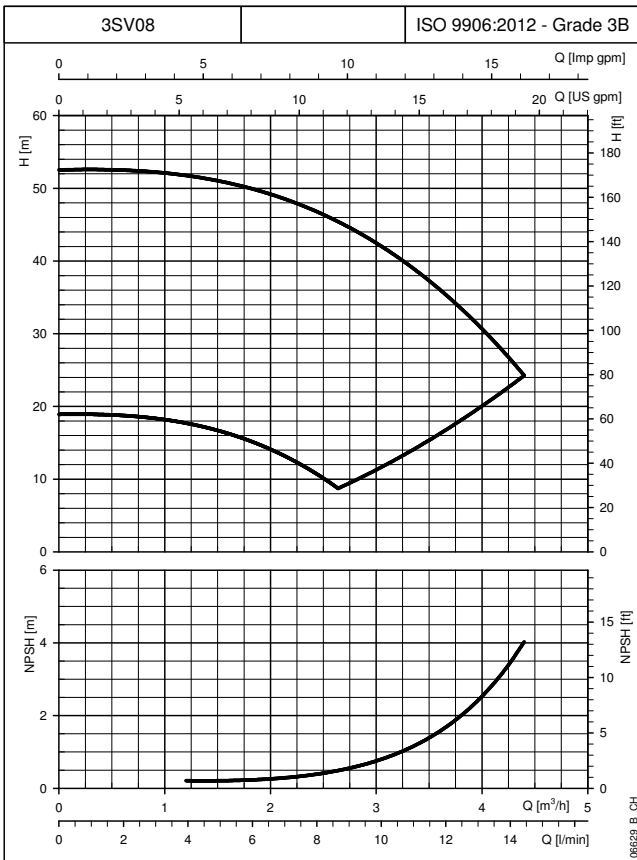

The curves show the performance with one pump running to the minimum and maximum speed. These performances are valid for liquids with density $\rho = 1.0 \text{ Kg/dm}^3$ and kinematic viscosity $\nu = 1 \text{ mm}^2/\text{s}$.

3SVH SERIES OPERATING CHARACTERISTICS AT 30..50 Hz

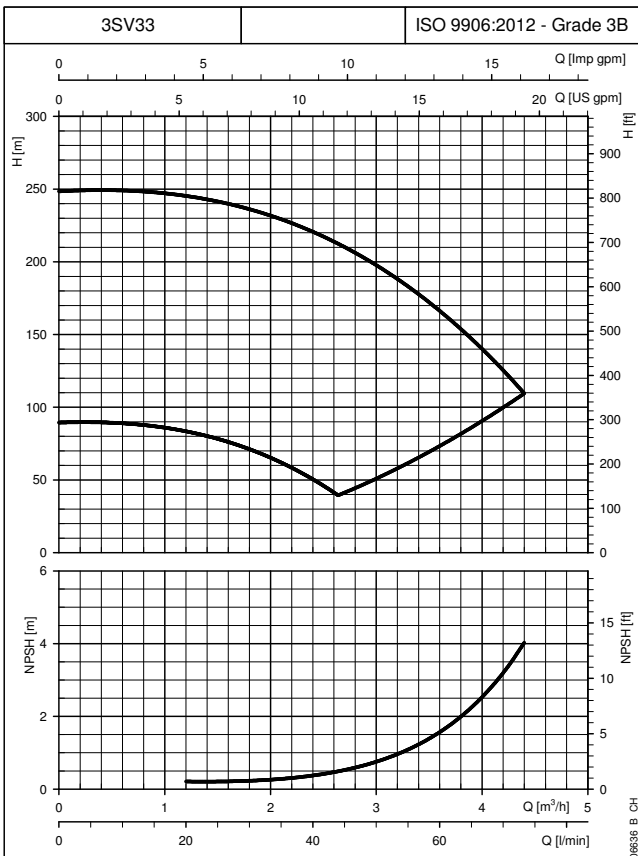
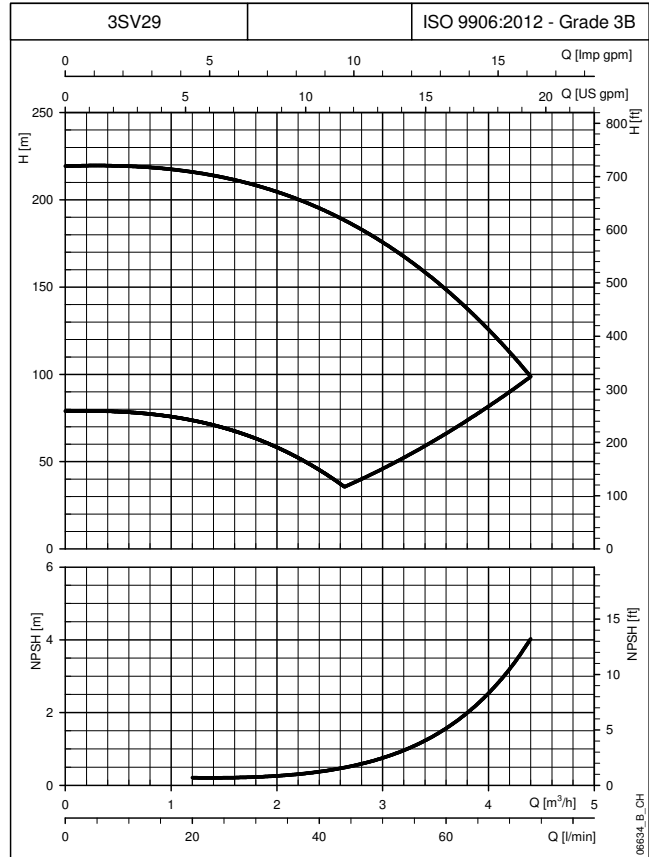
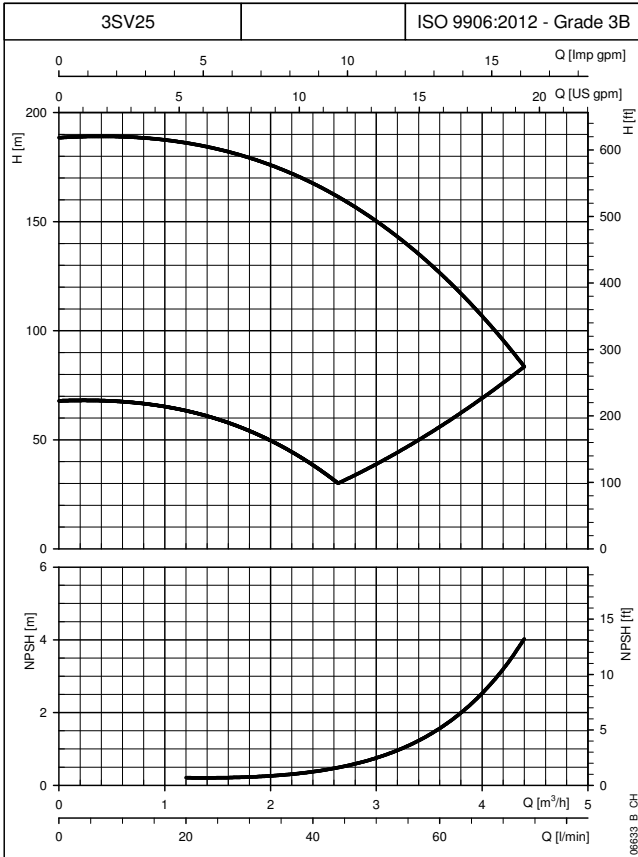

The curves show the performance with one pump running to the minimum and maximum speed. These performances are valid for liquids with density $\rho = 1.0 \text{ Kg/dm}^3$ and kinematic viscosity $\nu = 1 \text{ mm}^2/\text{s}$.

5SVH SERIES DIMENSIONS AND WEIGHTS AT 50 Hz, 2 POLES

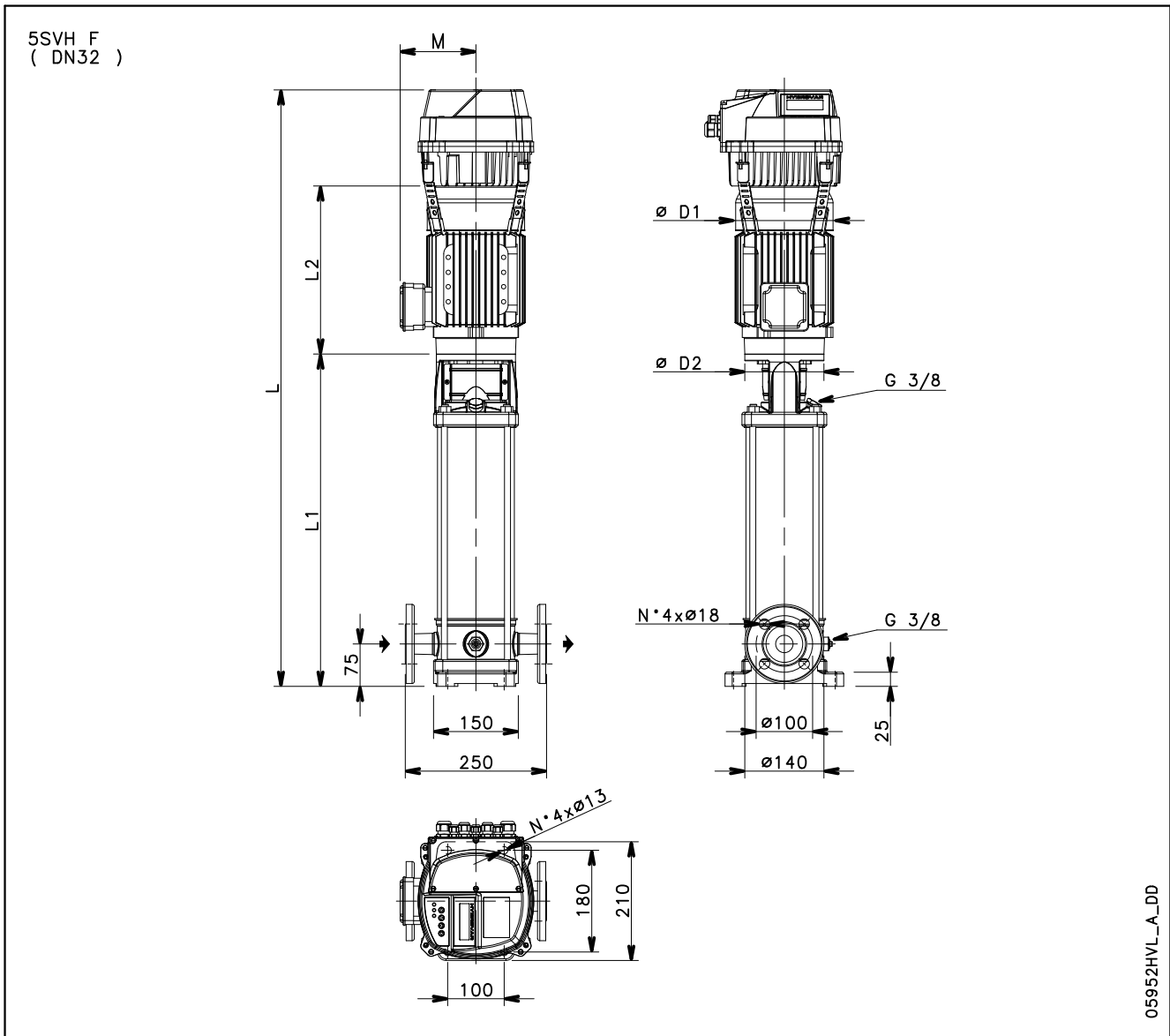

PUMP TYPE	MOTOR		DIMENSIONS (mm)					L			WEIGHT (kg)		
			L1	L2	M	D1	D2	/2	/3	/4	/2	/3	/4
				3 ~	3 ~	3 ~		1 ~ 230V	3 ~ 230V	3 ~ 400V	1 ~ 230V	3 ~ 230V	3 ~ 400V
5SVH05	0,75	80	353	263	129	155	120	786	786	786	25,7	25,7	25,7
5SVH08	1,1	80	428	263	129	155	120	861	861	861	29,1	29,1	29,1
5SVH11	1,5	90	513	263	129	155	140	946	946	946	32,6	32,6	32,6
5SVH14	2,2	90	588	298	134	174	140	1056	1056	1056	38,8	38,8	38,8
5SVH16	2,2	90	638	298	134	174	140	1106	1106	1106	39,8	39,8	39,8
5SVH21	3	100	773	298	134	174	160	1256	1256	1241	50,9	50,9	46,0
5SVH28	4	112	948	319	154	197	160	1452	1452	1437	59,9	59,9	55,0
5SVH33	5,5	132	1093	375	168	214	300	-	1653	1653	-	77,6	77,6

3svh-HVL-2p50-en_a_td

5SVH SERIES OPERATING CHARACTERISTICS AT 30..50 Hz

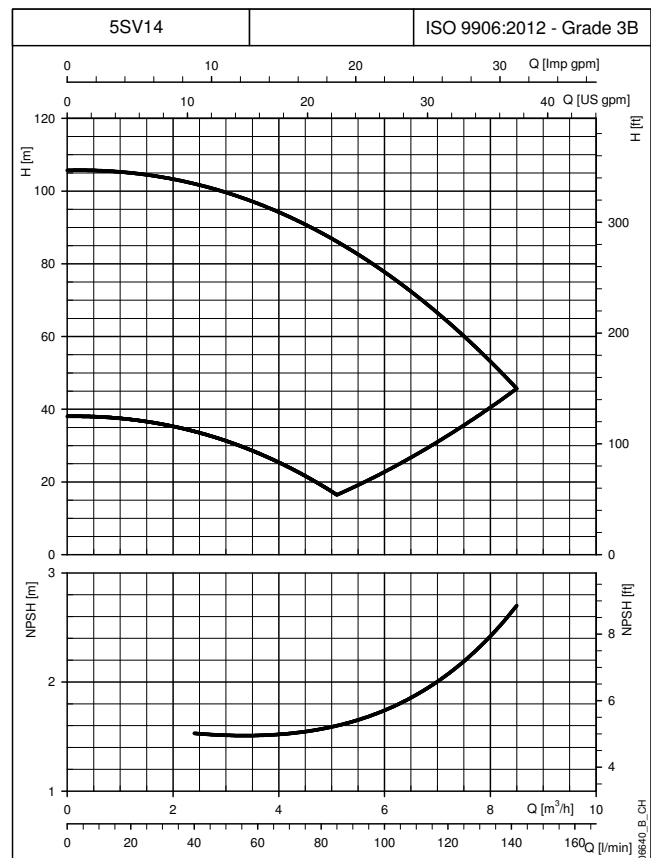
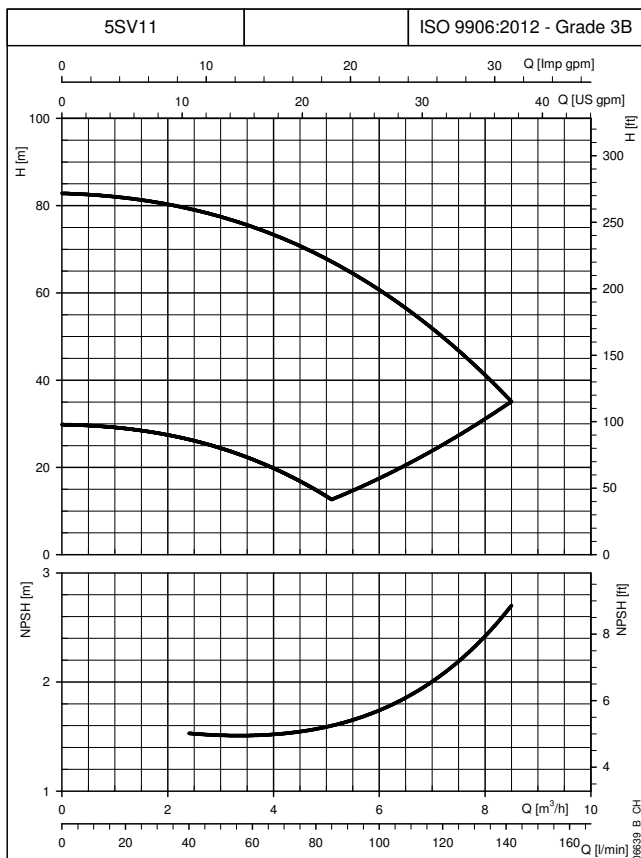
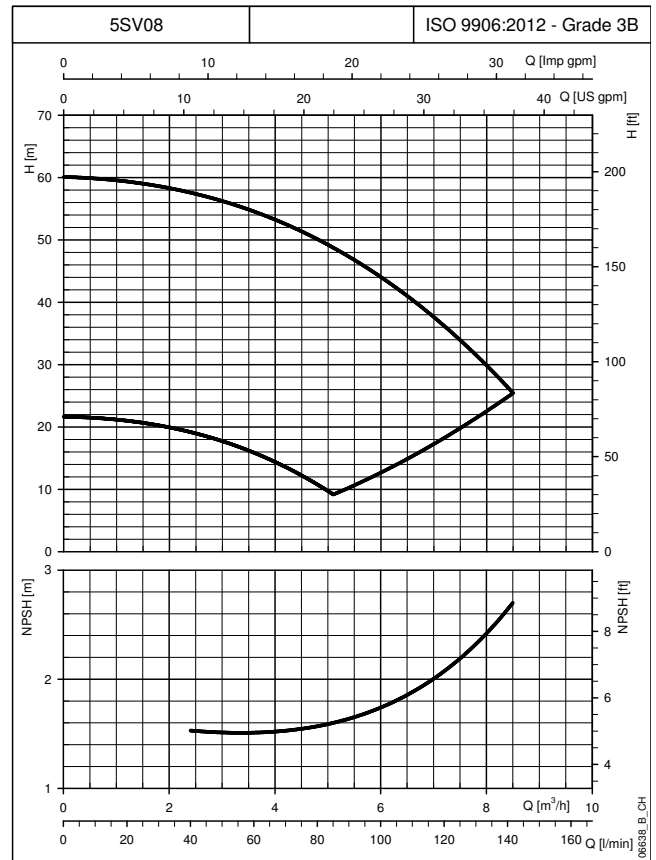
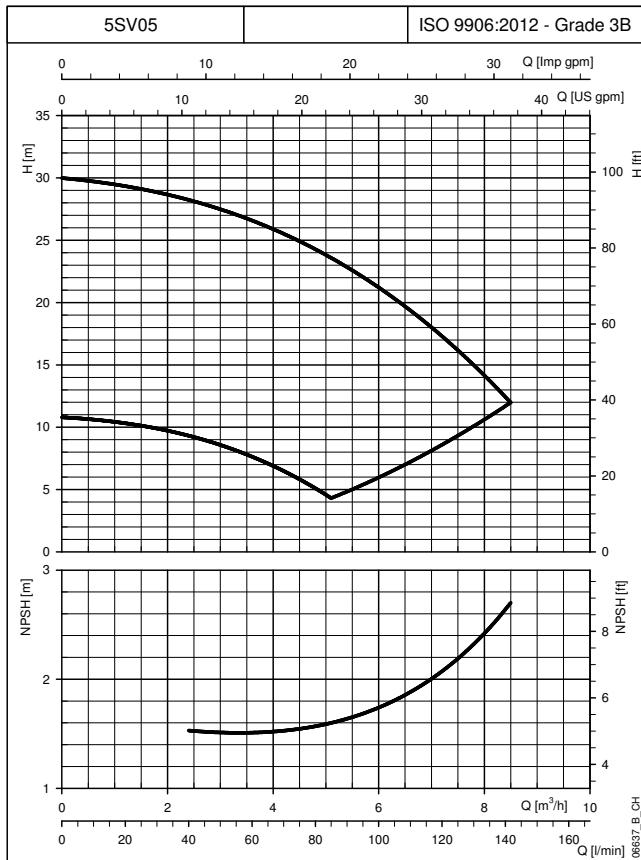

The curves show the performance with one pump running to the minimum and maximum speed.
 These performances are valid for liquids with density $\rho = 1.0 \text{ Kg/dm}^3$ and kinematic viscosity $\nu = 1 \text{ mm}^2/\text{s}$.

5SVH SERIES OPERATING CHARACTERISTICS AT 30..50 Hz

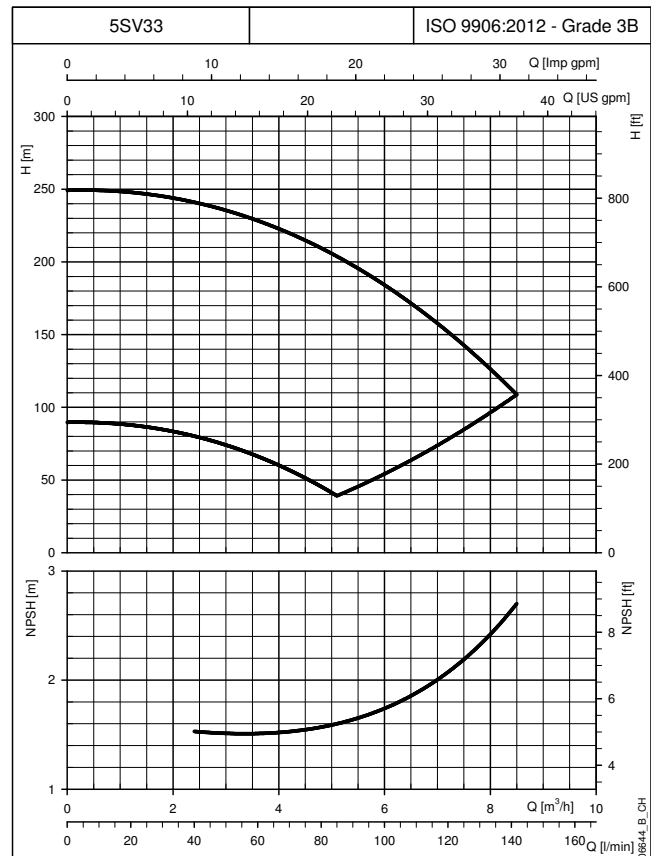
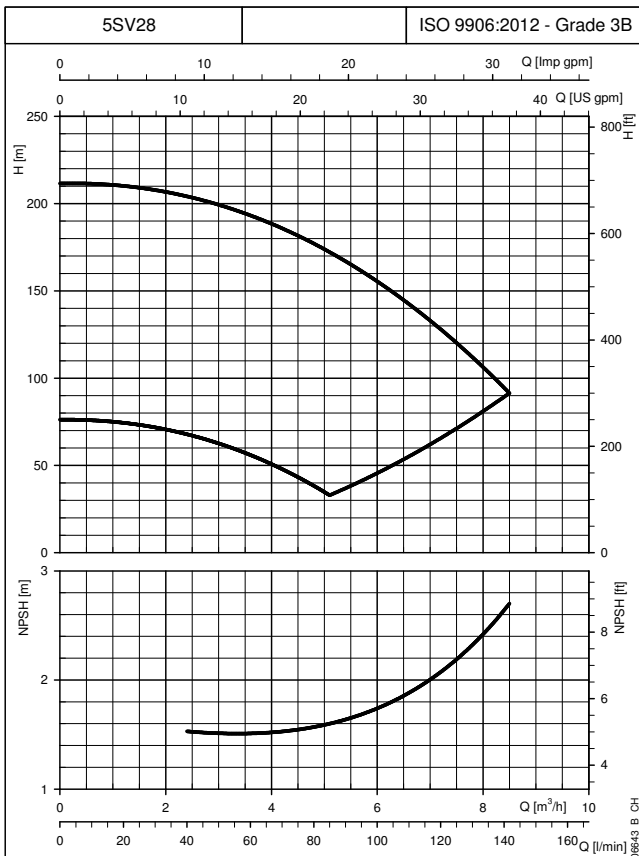
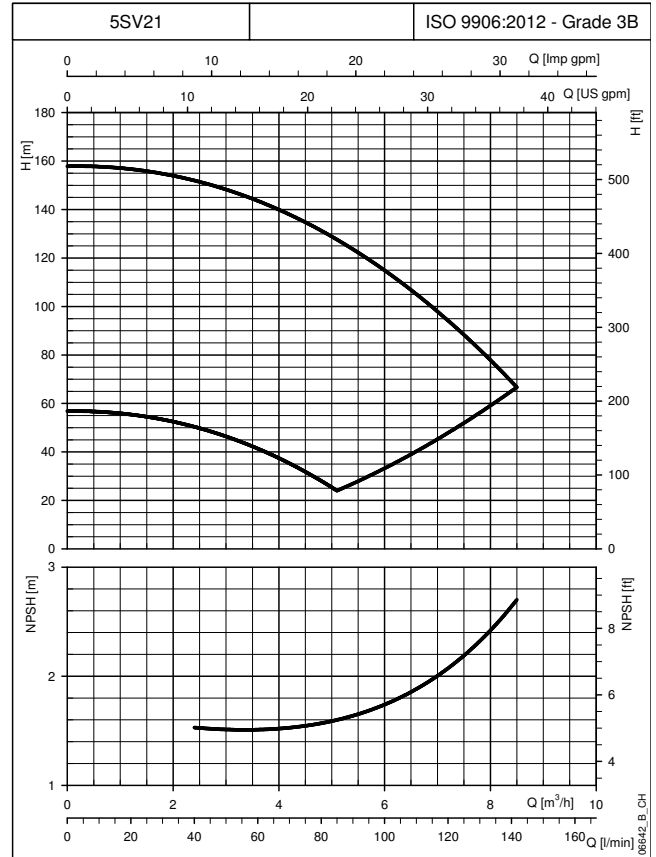
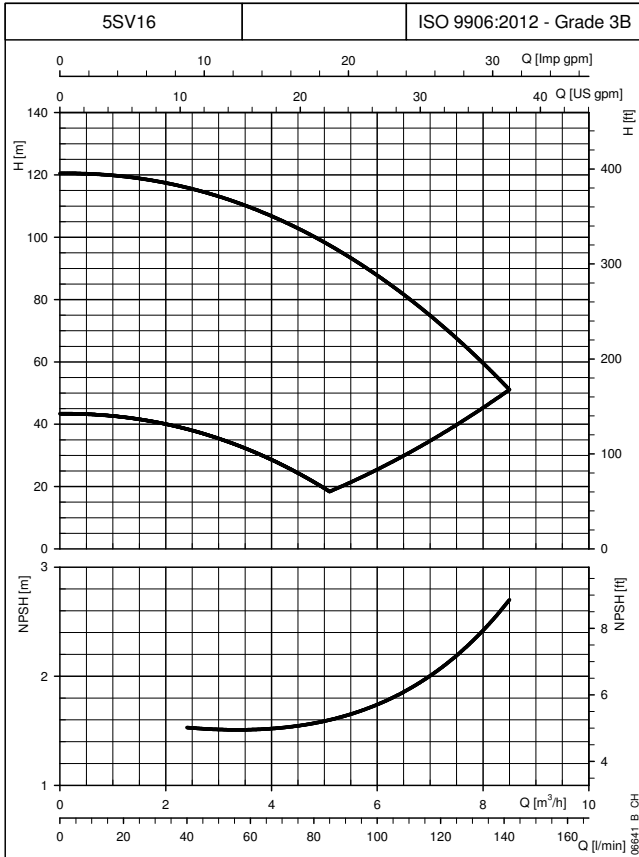

The curves show the performance with one pump running to the minimum and maximum speed. These performances are valid for liquids with density $\rho = 1.0 \text{ Kg/dm}^3$ and kinematic viscosity $\nu = 1 \text{ mm}^2/\text{s}$.

10SVH SERIES DIMENSIONS AND WEIGHTS AT 50 Hz, 2 POLES

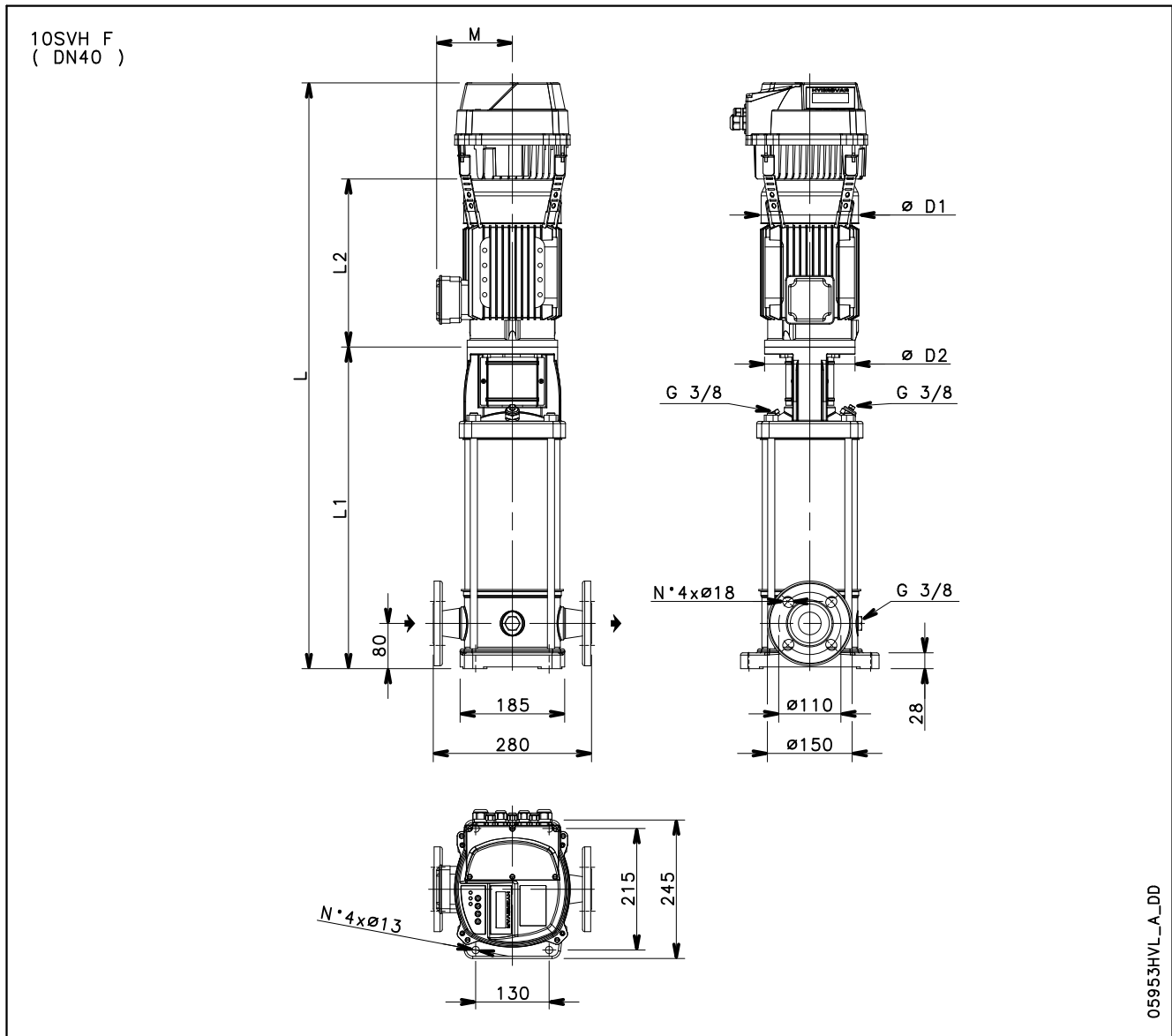

PUMP TYPE	MOTOR		DIMENSIONS (mm)					L			WEIGHT (kg)		
			L1	L2	M	D1	D2	/2	/3	/4	/2	/3	/4
				3 ~	3 ~	3 ~		1 ~ 230V	3 ~ 230V	3 ~ 400V	1 ~ 230V	3 ~ 230V	3 ~ 400V
10SVH04	1,5	90	431	263	129	155	140	864	864	864	36,6	36,6	36,6
10SVH06	2,2	90	495	298	134	174	140	963	963	963	43,5	43,5	43,5
10SVH08	3	100	569	298	134	174	160	1052	1052	1037	53,9	53,9	49,0
10SVH11	4	112	665	319	154	197	160	1169	1169	1154	62,5	62,5	57,6
10SVH15	5,5	132	860	375	168	214	300	-	1420	1420	-	83,5	83,5
10SVH20	7,5	132	1020	367	191	256	300	-	1587	1572	-	111,6	106,5
10SVH21	11	160	1082	428	191	256	350	-	1710	1695	-	128,6	123,5

10svh-HVL-2p50-en_a_td

10SVH SERIES

OPERATING CHARACTERISTICS AT 30..50 Hz

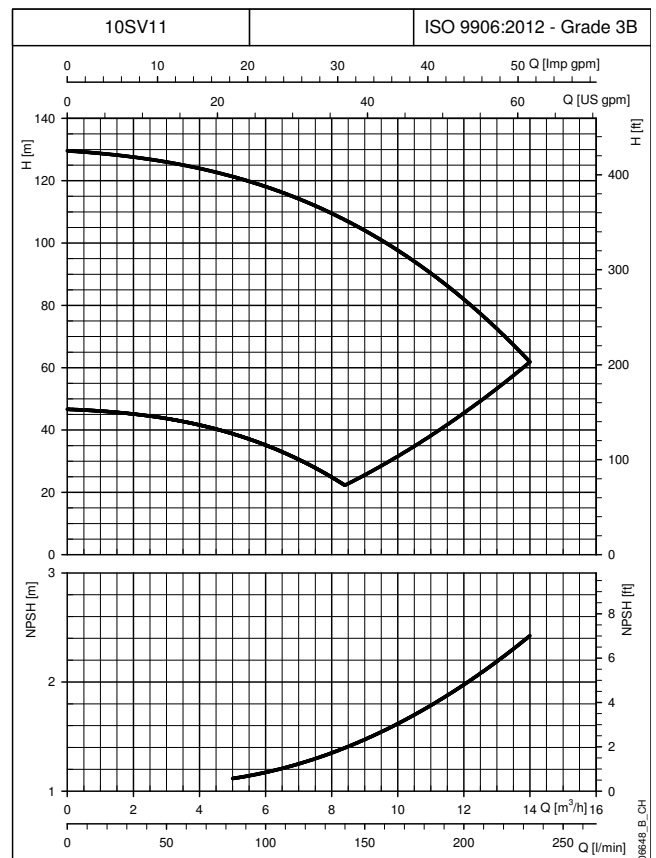
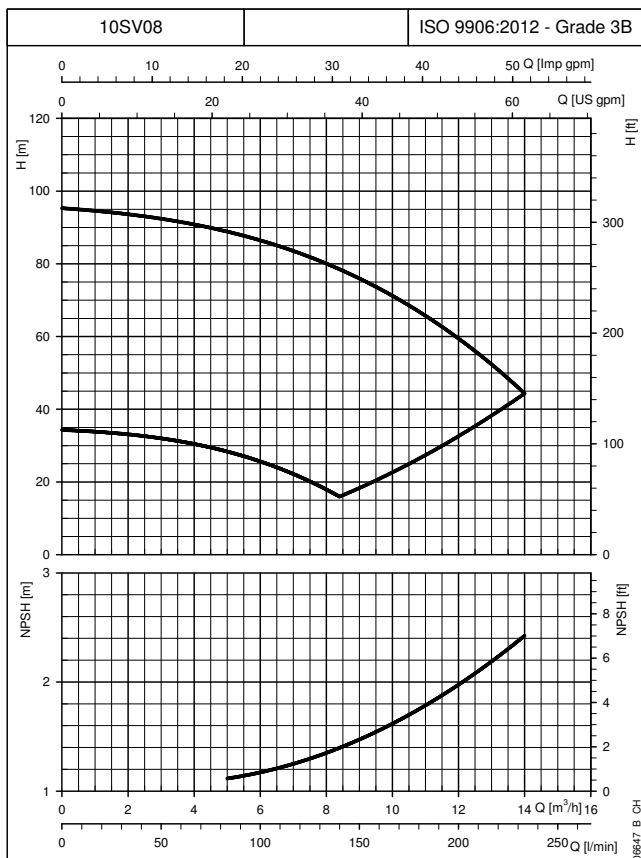
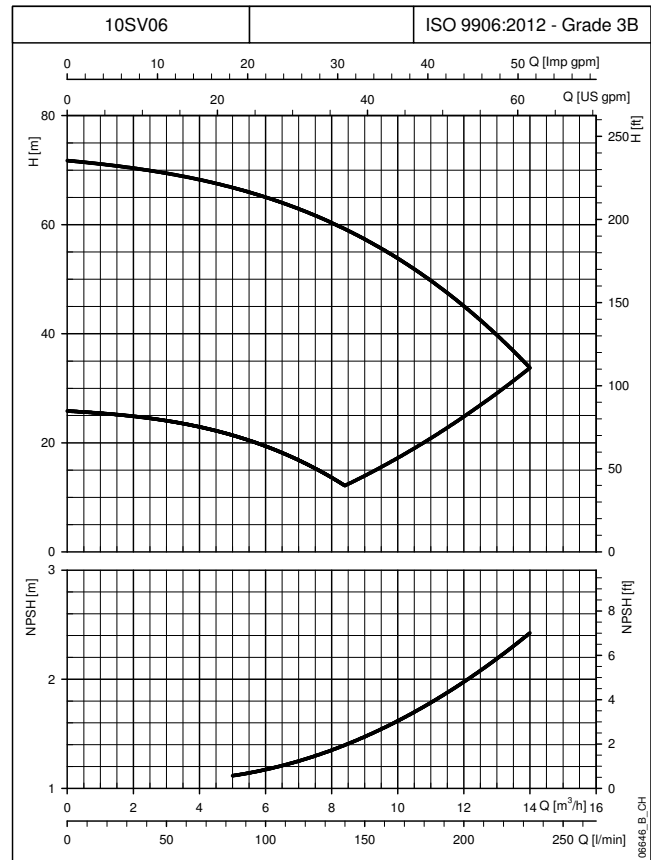
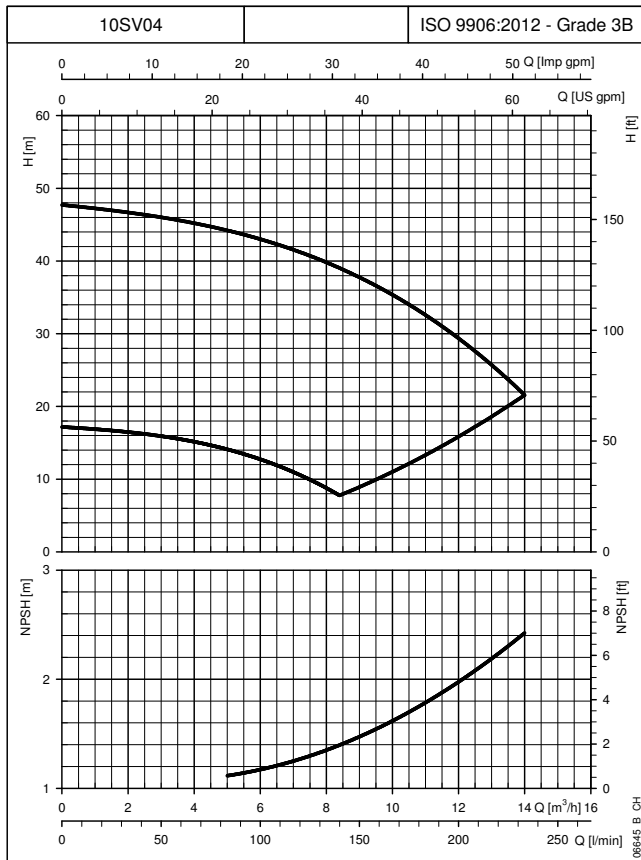

The curves show the performance with one pump running to the minimum and maximum speed. These performances are valid for liquids with density $\rho = 1.0 \text{ Kg/dm}^3$ and kinematic viscosity $\nu = 1 \text{ mm}^2/\text{s}$.

10SVH SERIES OPERATING CHARACTERISTICS AT 30..50 Hz

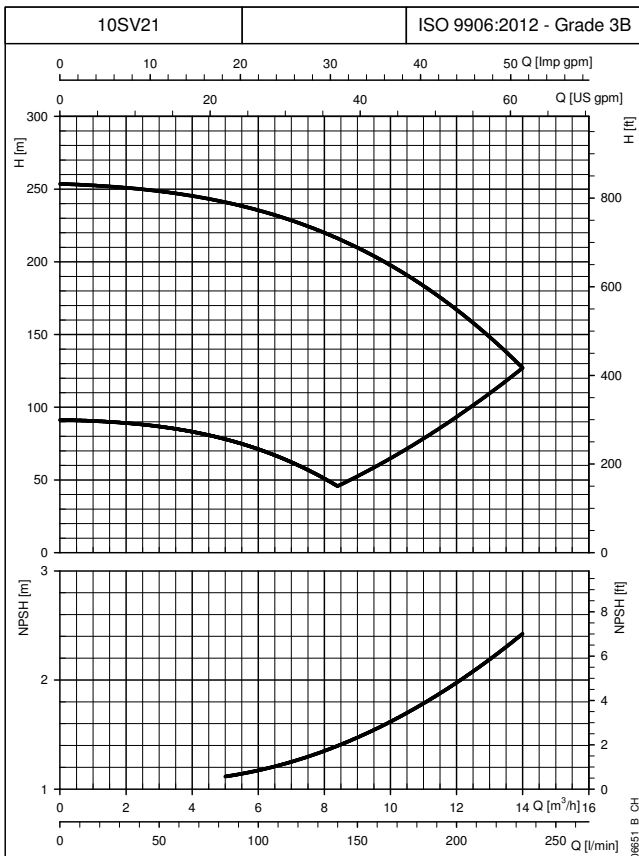
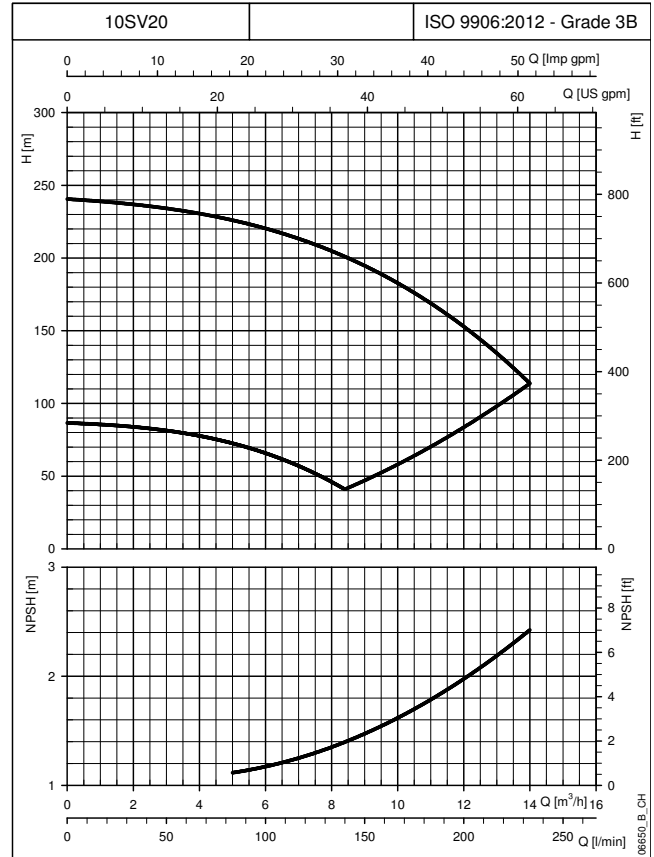
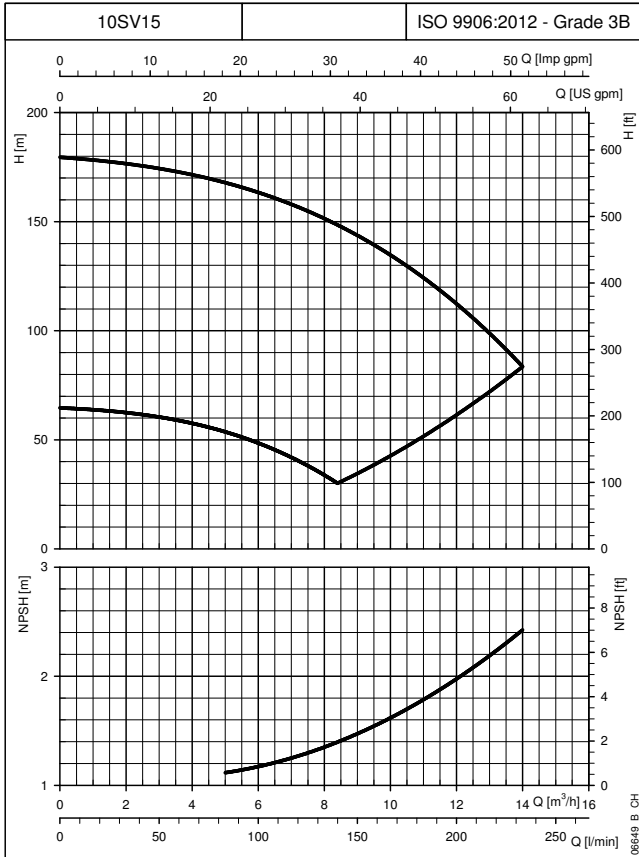

The curves show the performance with one pump running to the minimum and maximum speed. These performances are valid for liquids with density $\rho = 1.0 \text{ Kg/dm}^3$ and kinematic viscosity $\nu = 1 \text{ mm}^2/\text{s}$.

15SVH SERIES DIMENSIONS AND WEIGHTS AT 50 Hz, 2 POLES

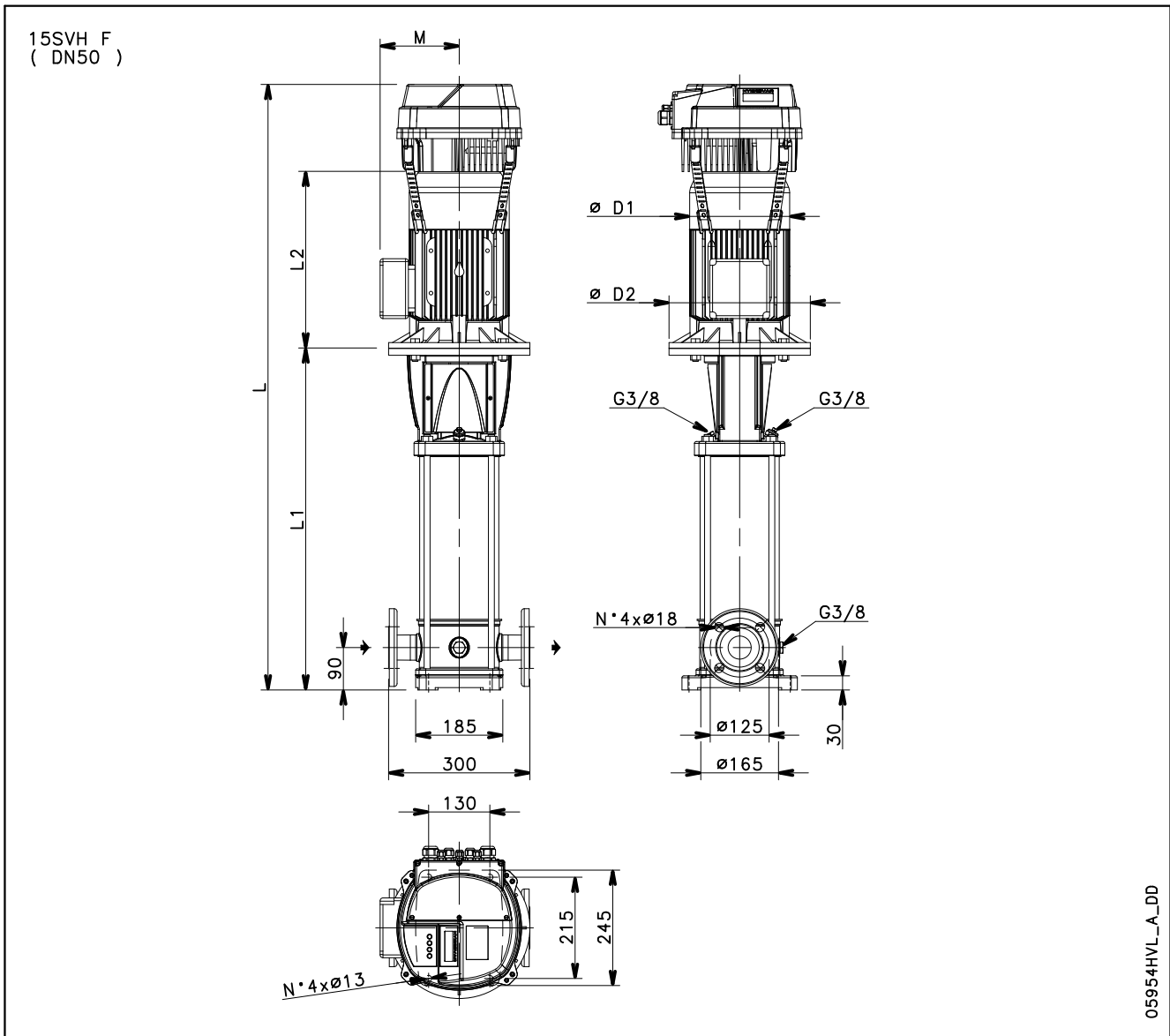

PUMP TYPE	MOTOR		DIMENSIONS (mm)					L			WEIGHT (kg)		
			L1	L2	M	D1	D2	/2	/3	/4	/2	/3	/4
								1 ~ 230V	3 ~ 230V	3 ~ 400V	1 ~ 230V	3 ~ 230V	3 ~ 400V
15SVH02	2,2	90	409	298	134	174	140	877	877	877	40,3	40,3	40,3
15SVH03	3	100	467	298	134	174	160	950	950	935	50,5	50,5	45,6
15SVH05	4	112	563	319	154	197	160	1067	1067	1052	58,4	58,4	53,5
15SVH07	5,5	132	726	375	168	214	300	-	1286	1286	-	78,5	78,5
15SVH09	7,5	132	822	367	191	256	300	-	1389	1374	-	105,6	100,5
15SVH13	11	160	1044	428	191	256	350	-	1672	1657	-	127,6	122,5
15SVH17	15	160	1236	494	240	313	350	-	-	1930	-	-	164,6

15svh-HVL-2p50-en_a_td

15SVH SERIES

OPERATING CHARACTERISTICS AT 30..50 Hz

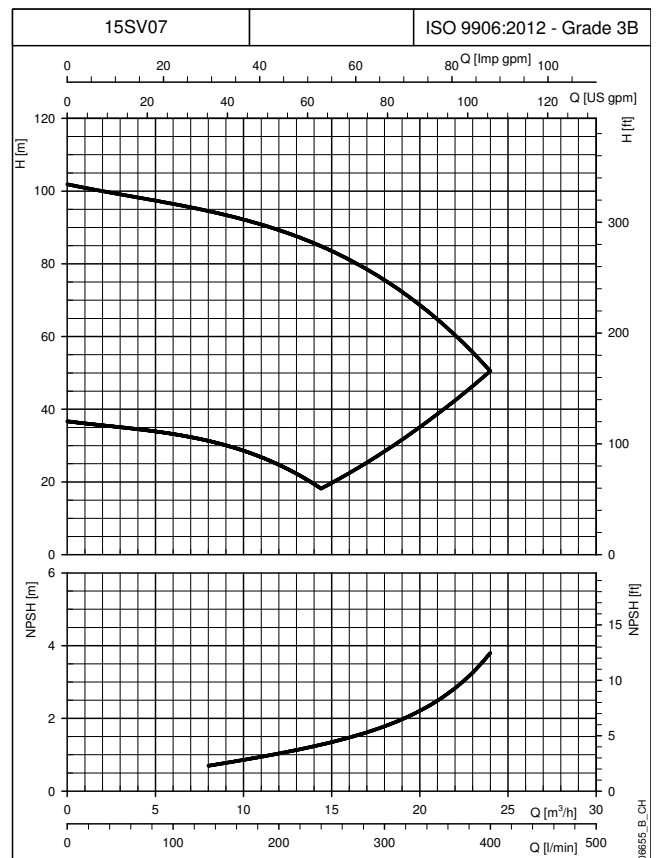
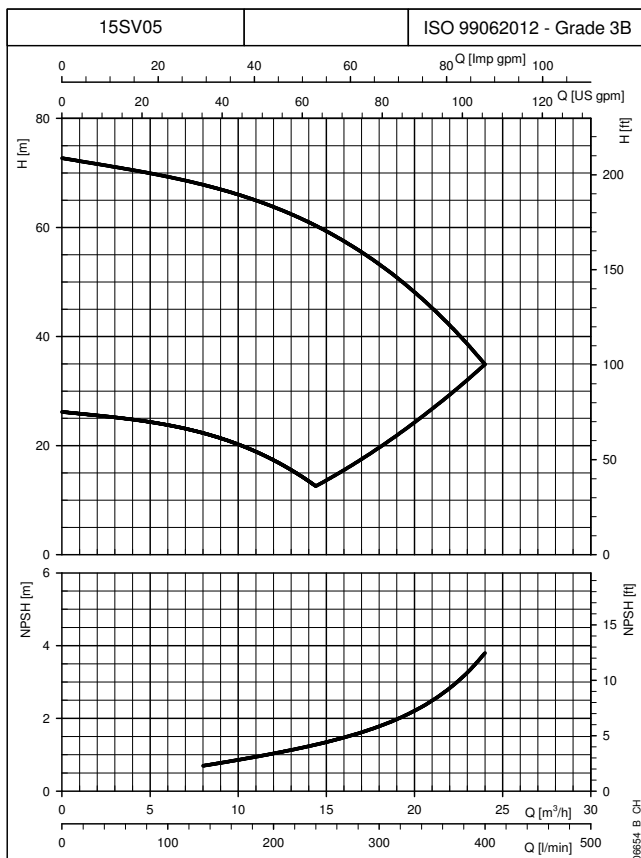
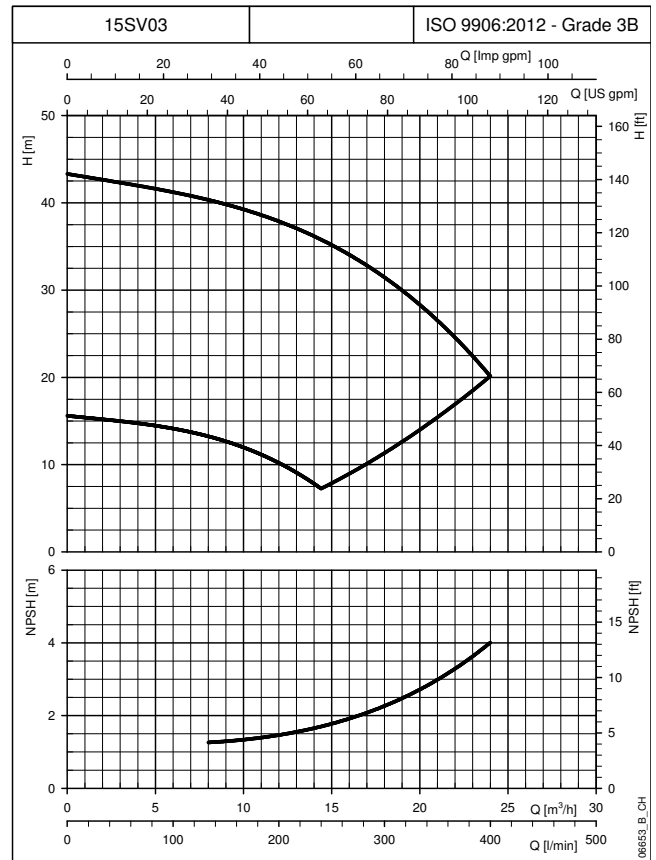
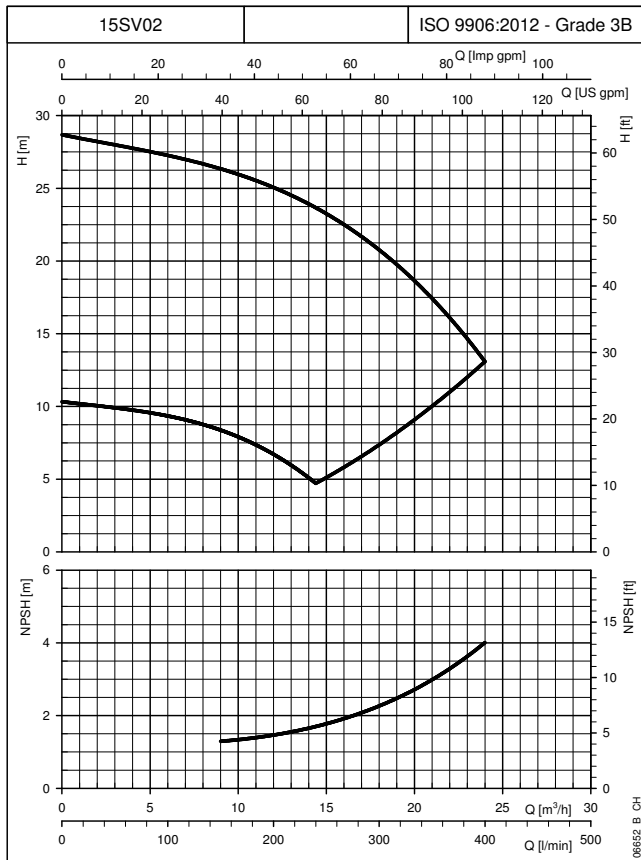

The curves show the performance with one pump running to the minimum and maximum speed. These performances are valid for liquids with density $\rho = 1.0 \text{ Kg/dm}^3$ and kinematic viscosity $\nu = 1 \text{ mm}^2/\text{s}$.

15SVH SERIES OPERATING CHARACTERISTICS AT 30..50 Hz

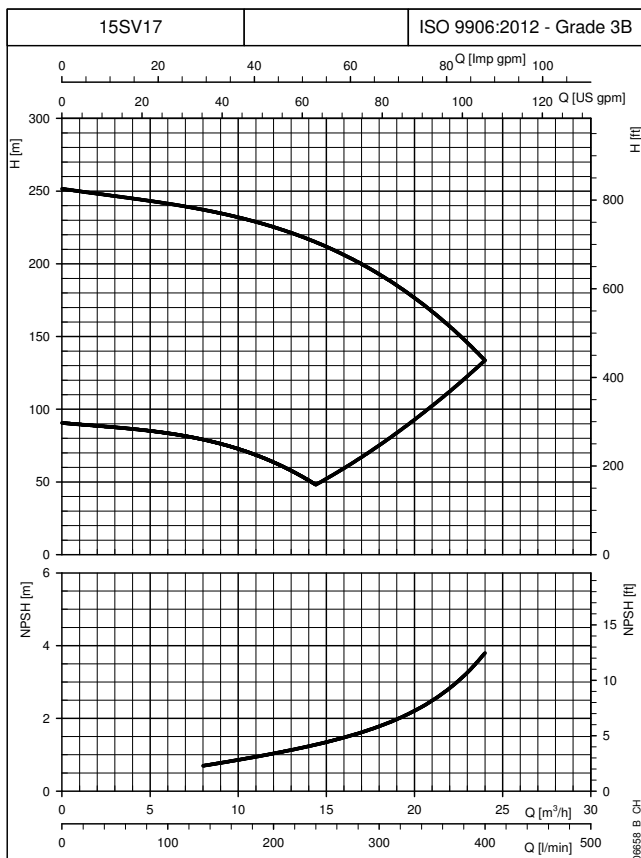
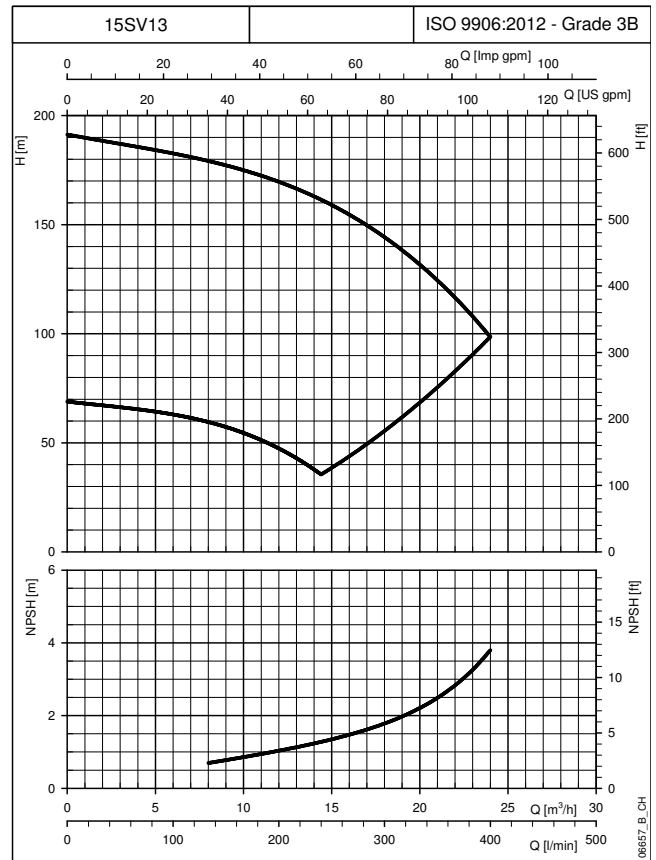
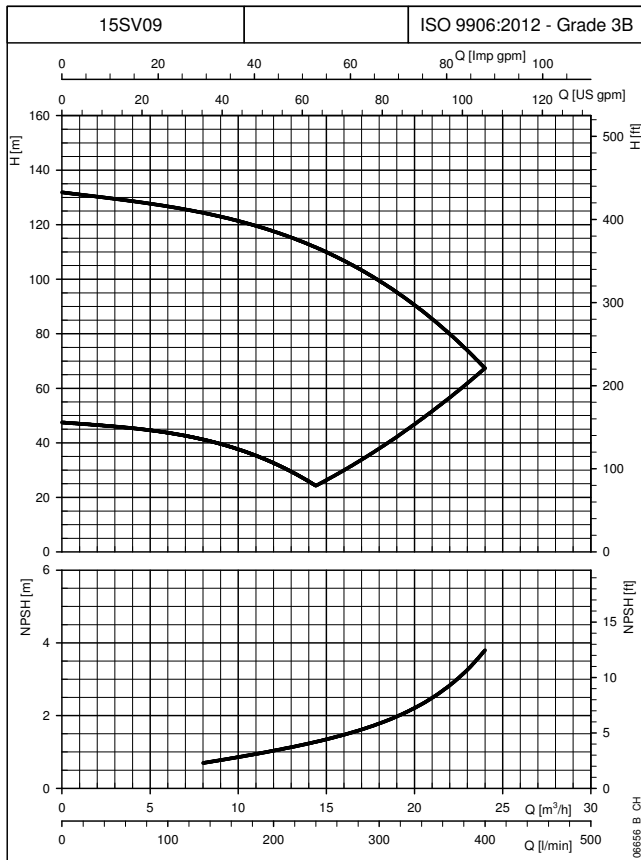

The curves show the performance with one pump running to the minimum and maximum speed. These performances are valid for liquids with density $\rho = 1.0 \text{ Kg/dm}^3$ and kinematic viscosity $\nu = 1 \text{ mm}^2/\text{s}$.

22SVH SERIES DIMENSIONS AND WEIGHTS AT 50 Hz, 2 POLES

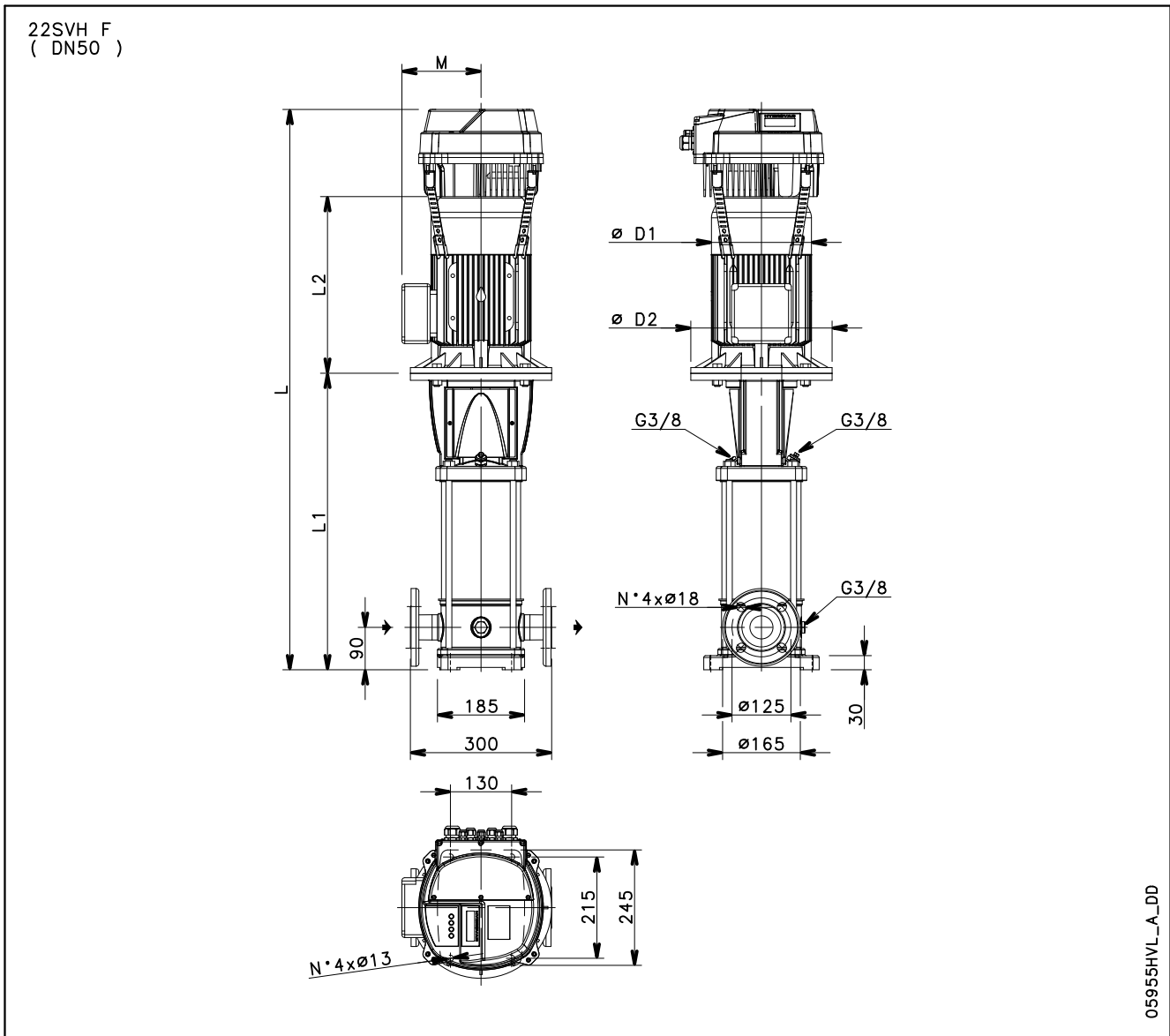

PUMP TYPE	MOTOR		DIMENSIONS (mm)					L			WEIGHT (kg)		
			L1	L2	M	D1	D2	/2	/3	/4	/2	/3	/4
				3 ~	3 ~	3 ~		1 ~ 230V	3 ~ 230V	3 ~ 400V	1 ~ 230V	3 ~ 230V	3 ~ 400V
22SVH01	1,1	80	399	263	129	155	120	832	832	832	32,5	32,5	32,5
22SVH03	3	100	467	298	134	174	160	950	950	935	50,9	50,9	46,0
22SVH04	4	112	515	319	154	197	160	1019	1019	1004	57,6	57,6	52,7
22SVH05	5,5	132	630	375	168	214	300	-	1190	1190	-	75,5	75,5
22SVH07	7,5	132	726	367	191	256	300	-	1293	1278	-	101,6	96,5
22SVH10	11	160	900	428	191	256	350	-	1528	1513	-	122,6	117,5
22SVH14	15	160	1092	494	240	313	350	-	-	1786	-	-	159,6
22SVH17	18,5	160	1236	494	240	313	350	-	-	1930	-	-	171,6

22svh-HVL-2p50-en_a_td

22SVH SERIES OPERATING CHARACTERISTICS AT 30..50 Hz

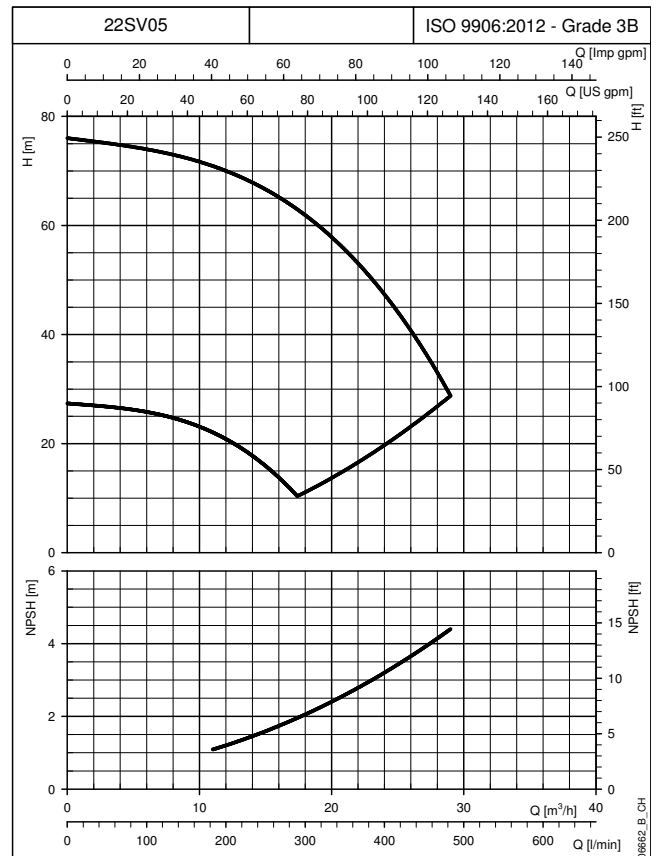
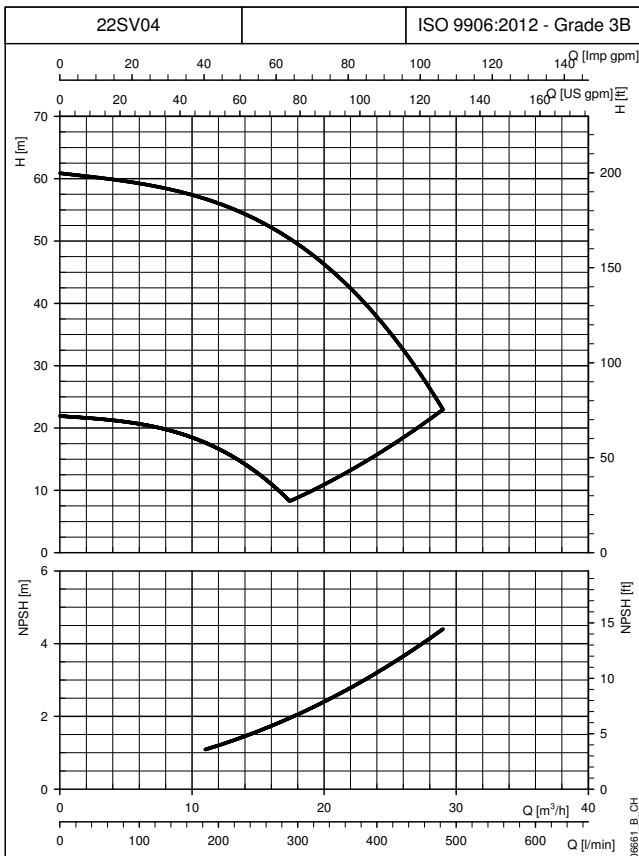
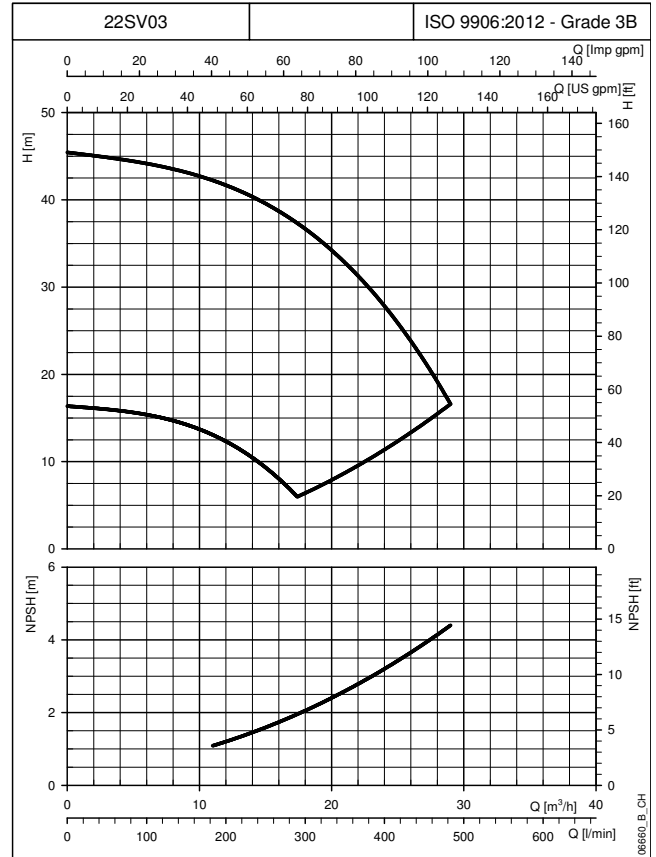
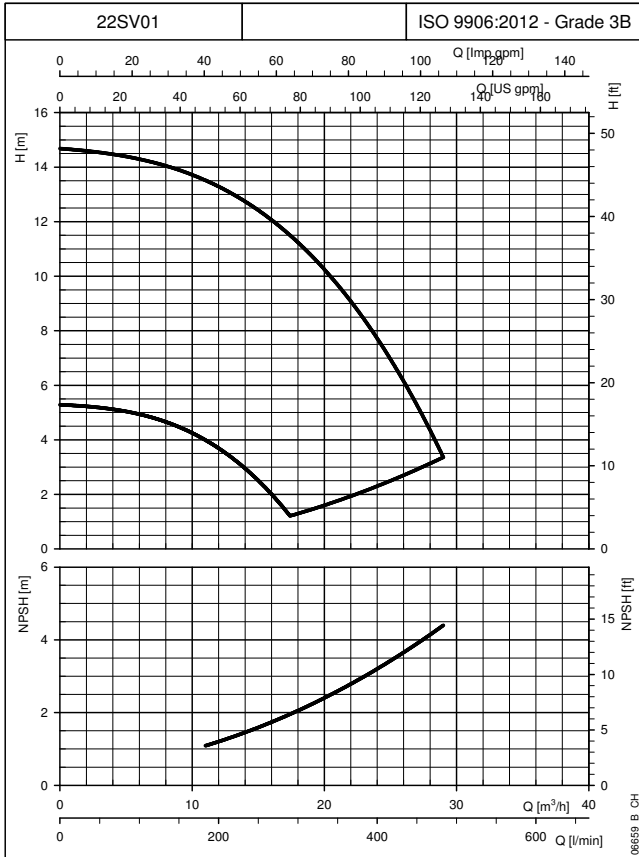

The curves show the performance with one pump running to the minimum and maximum speed.
 These performances are valid for liquids with density $\rho = 1.0 \text{ Kg/dm}^3$ and kinematic viscosity $\nu = 1 \text{ mm}^2/\text{s}$.

22SVH SERIES OPERATING CHARACTERISTICS AT 30..50 Hz

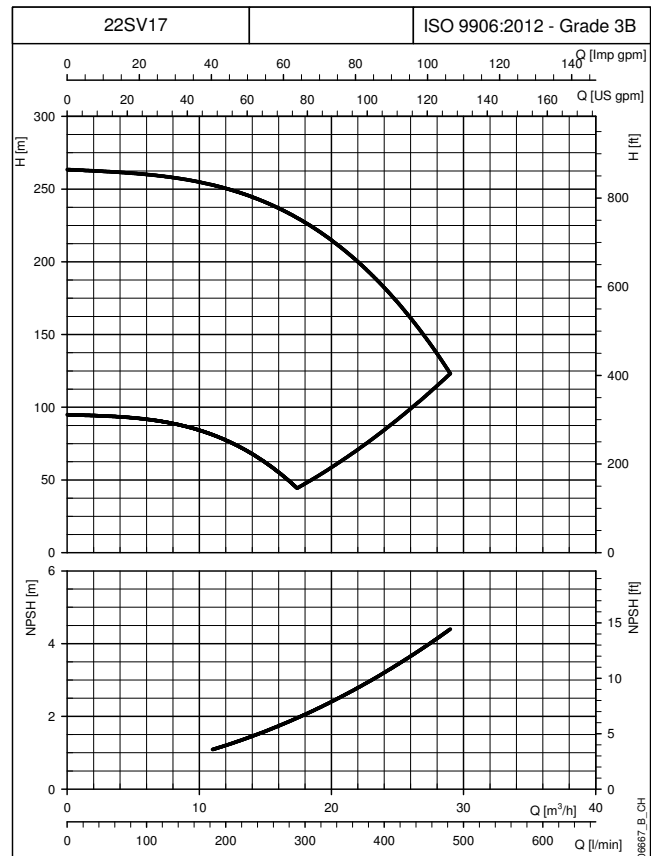
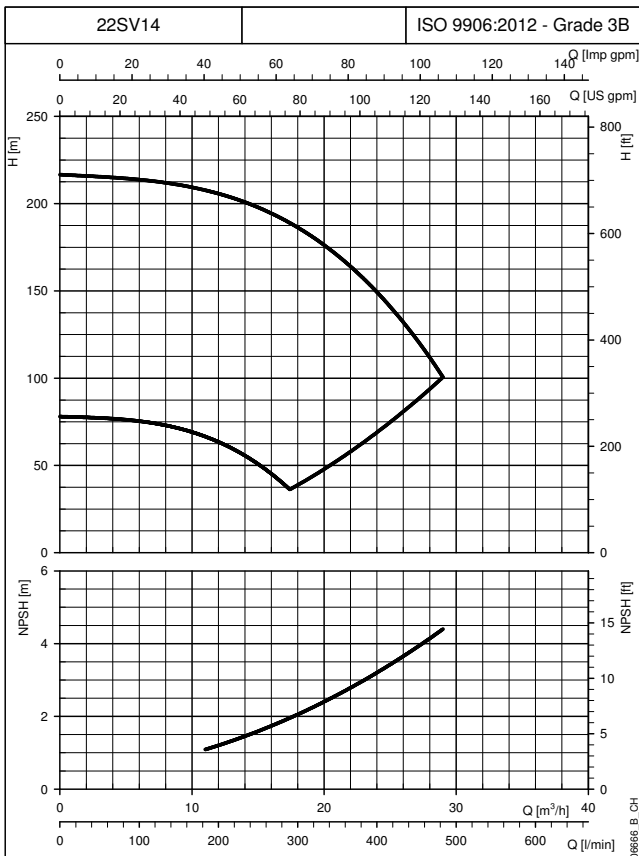
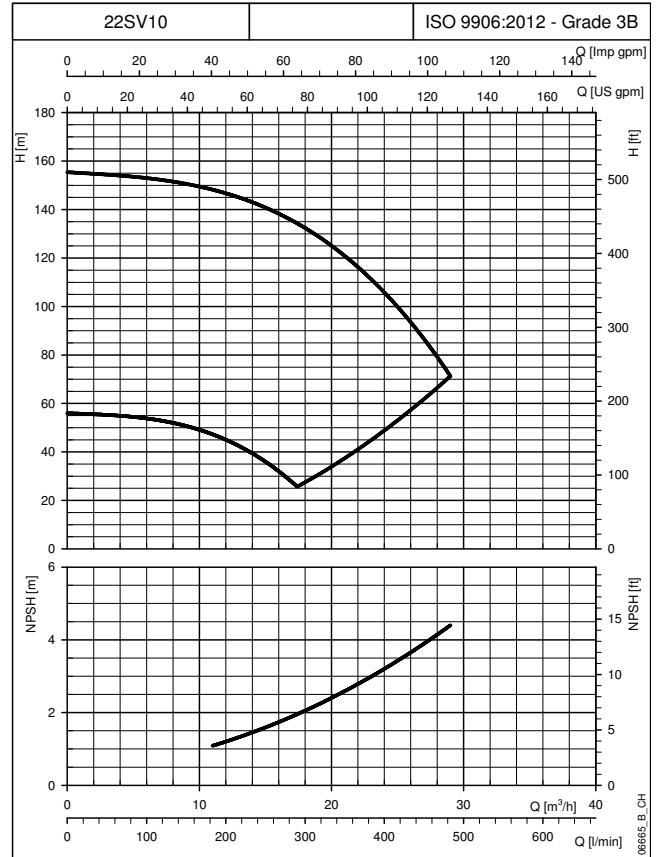
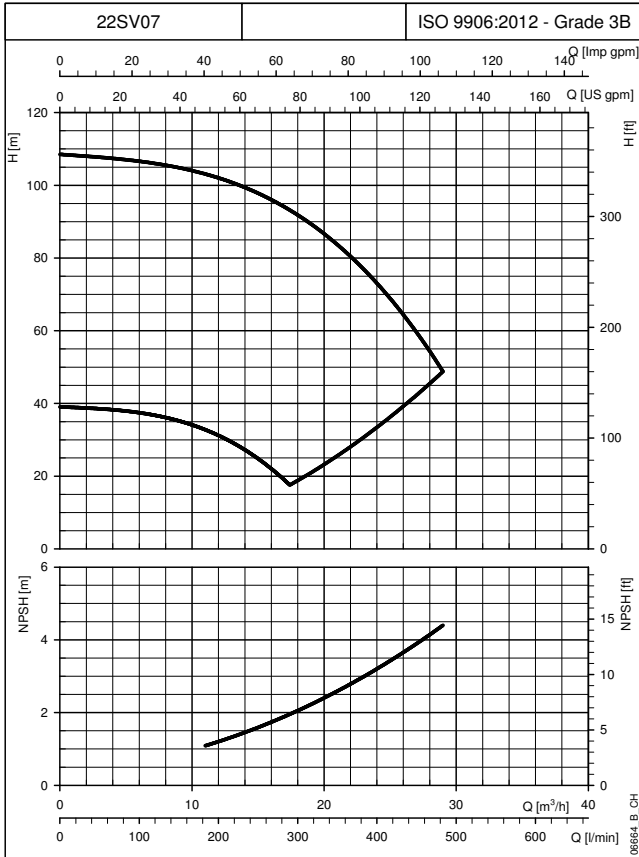

The curves show the performance with one pump running to the minimum and maximum speed. These performances are valid for liquids with density $\rho = 1.0 \text{ Kg/dm}^3$ and kinematic viscosity $\nu = 1 \text{ mm}^2/\text{s}$.

33SVH SERIES DIMENSIONS AND WEIGHTS AT 50 Hz, 2 POLES

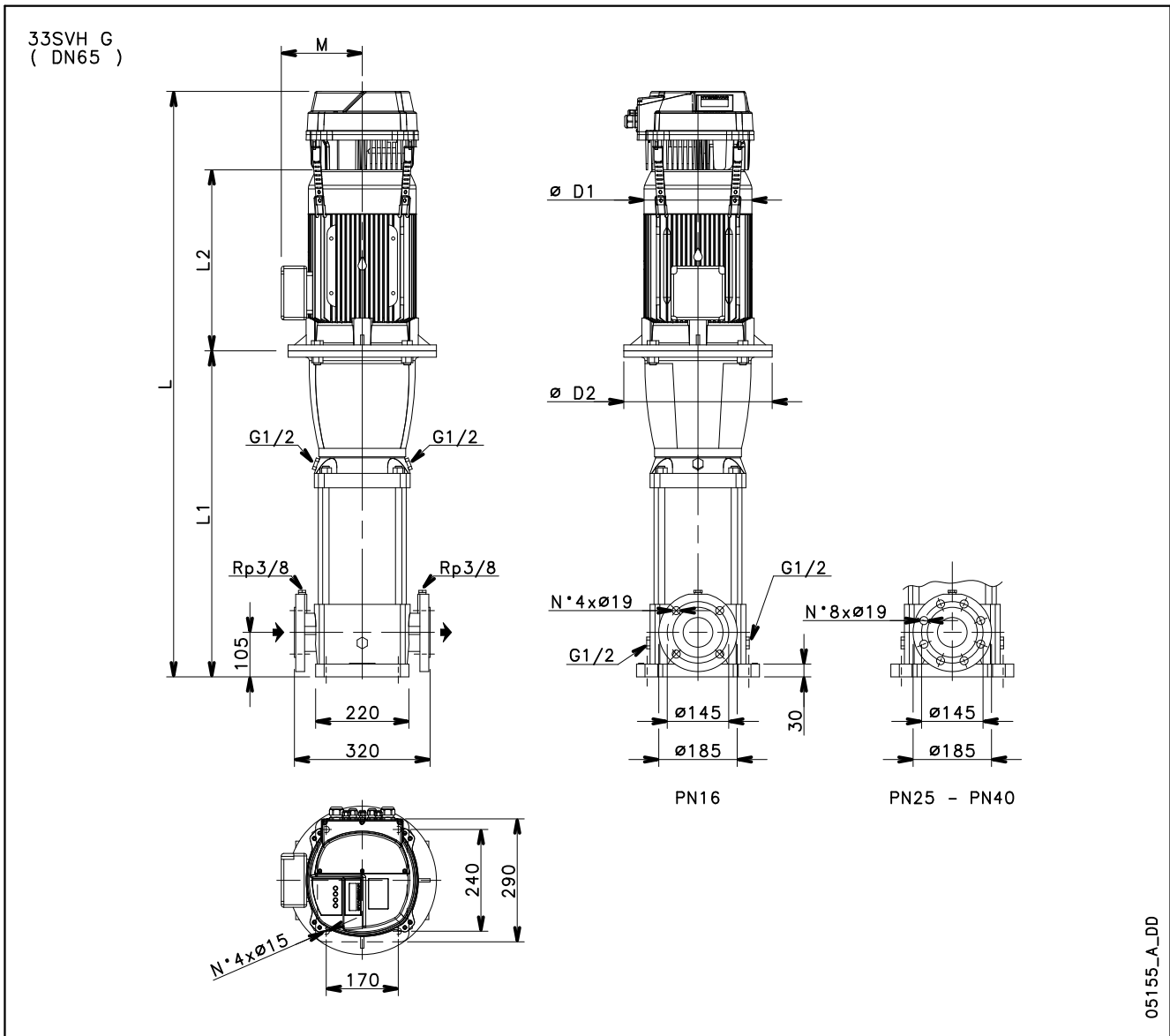

PUMP TYPE	MOTOR		DIMENSIONS (mm)						L			WEIGHT (kg)		
									/2	/3	/4	/2	/3	/4
									1~230V	3~230V	3~400V	1~230V	3~230V	3~400V
33SVH1	3	100	489	298	174	164	134	16	972	972	957	83,5	83,5	78,6
33SVH2	5,5	132	584	375	214	300	168	16	-	1144	1144	-	109,0	109,0
33SVH3	7,5	132	659	367	256	300	191	16	-	1226	1211	-	136,6	131,5
33SVH4	11	160	769	428	256	350	191	16	-	1397	1382	-	158,6	153,5
33SVH5	15	160	844	494	313	350	240	16	-	-	1538	-	-	194,6
33SVH6	15	160	919	494	313	350	240	25	-	-	1613	-	-	198,6
33SVH7	18,5	160	994	494	313	350	240	25	-	-	1688	-	-	210,6

33svh-HVL-2p50-en_a_td

33SVH SERIES OPERATING CHARACTERISTICS AT 30..50 Hz

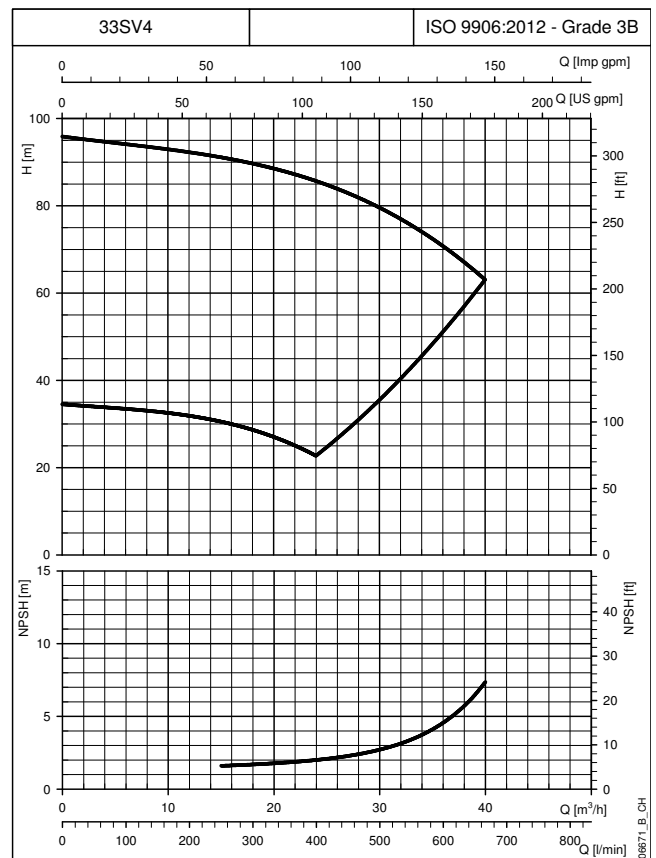
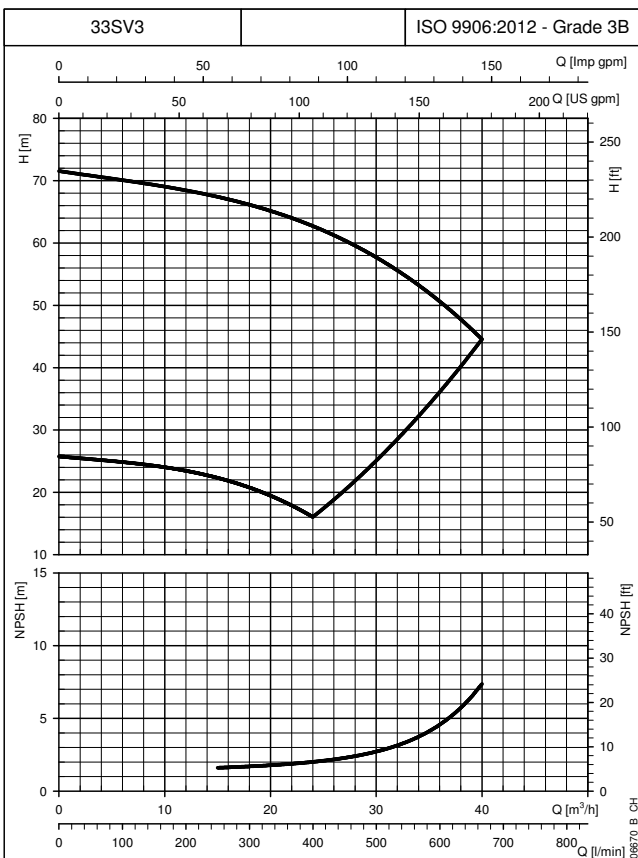
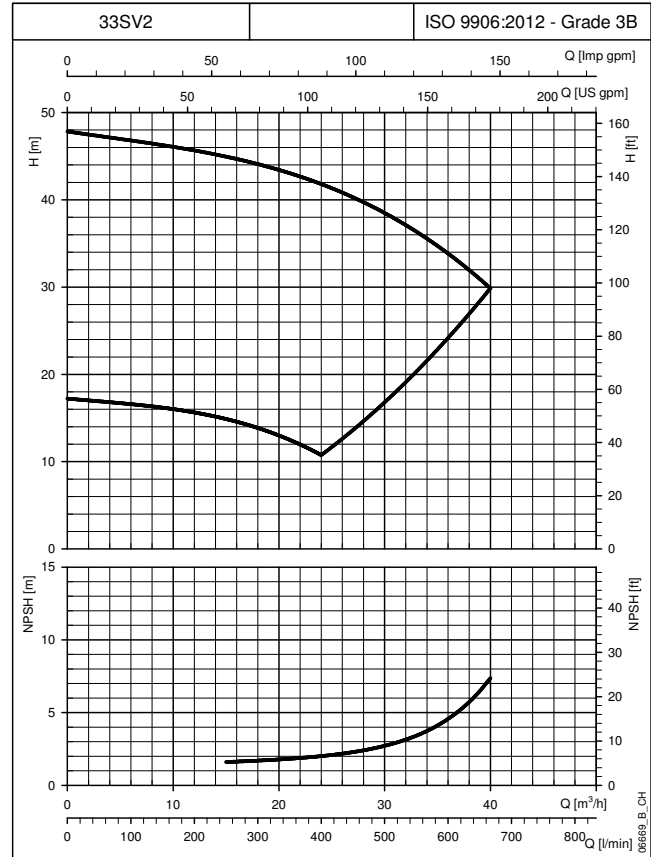
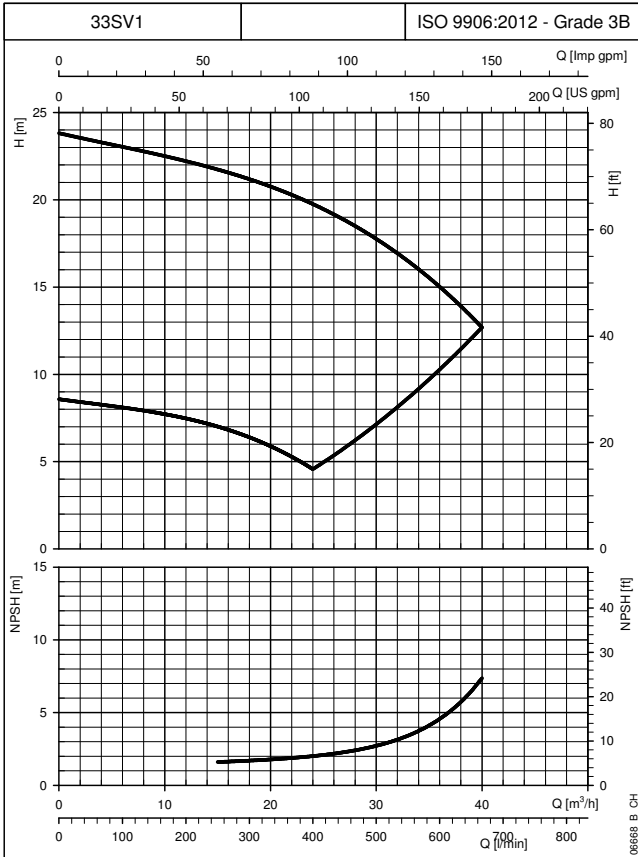

The curves show the performance with one pump running to the minimum and maximum speed. These performances are valid for liquids with density $\rho = 1.0 \text{ Kg/dm}^3$ and kinematic viscosity $\nu = 1 \text{ mm}^2/\text{s}$.

33SVH SERIES OPERATING CHARACTERISTICS AT 30..50 Hz

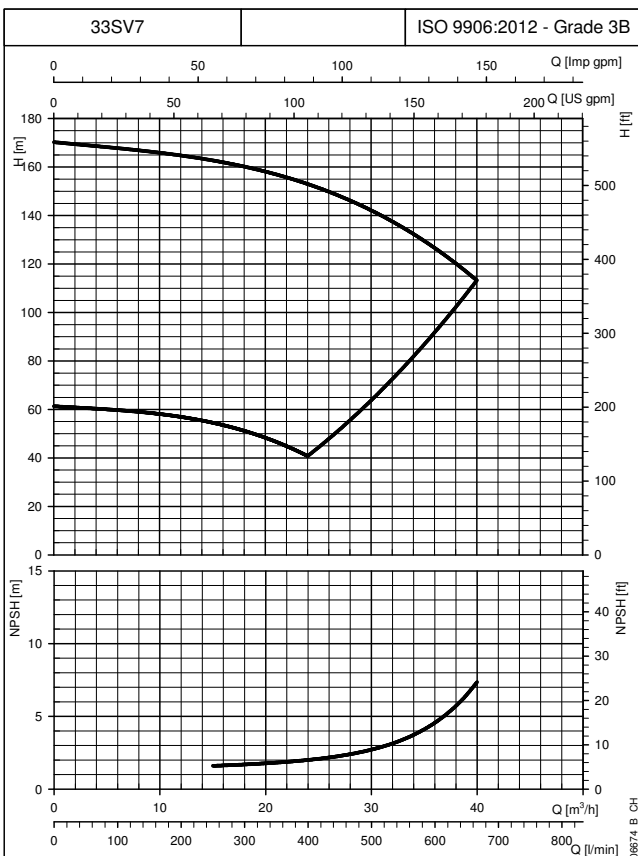
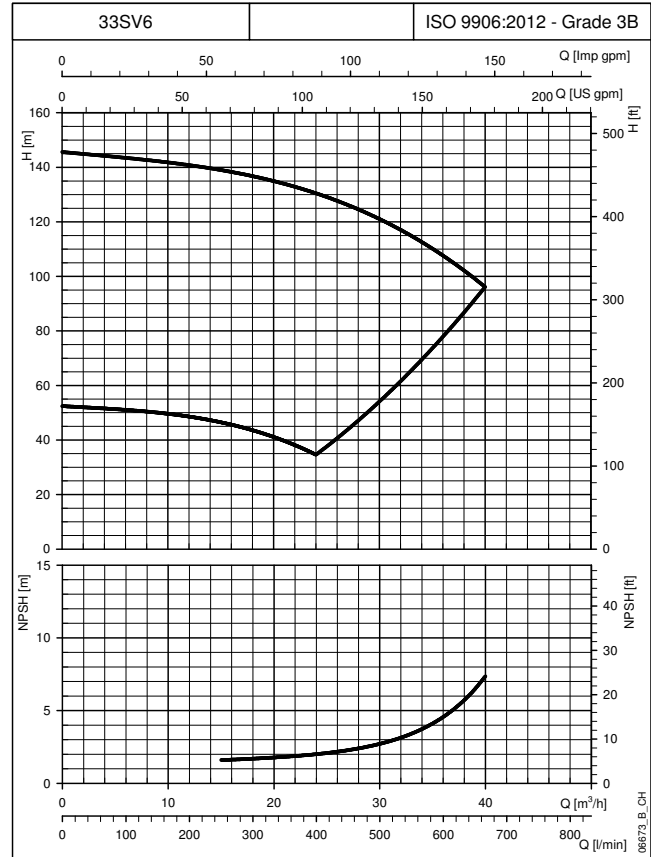
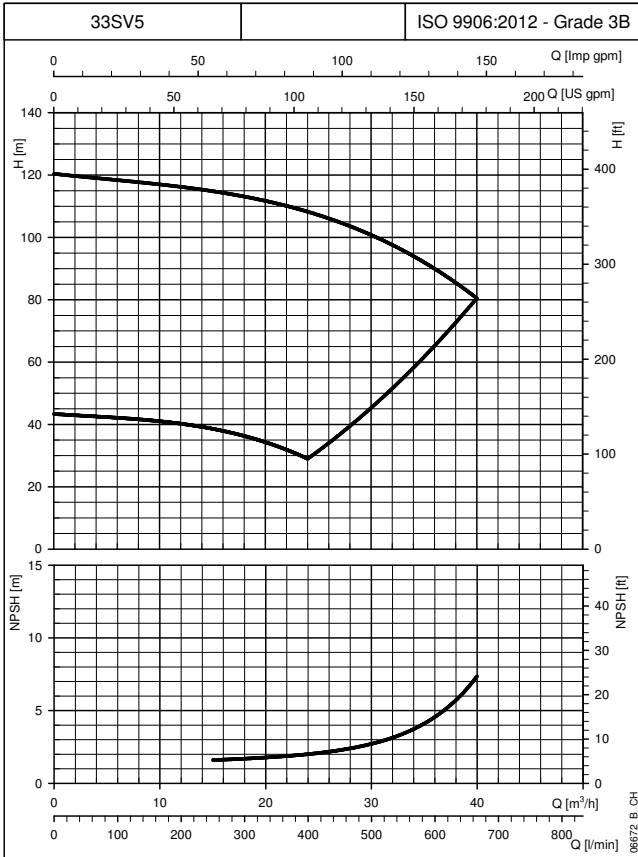

The curves show the performance with one pump running to the minimum and maximum speed. These performances are valid for liquids with density $\rho = 1.0 \text{ Kg/dm}^3$ and kinematic viscosity $\nu = 1 \text{ mm}^2/\text{s}$.

46SVH SERIES
DIMENSIONS AND WEIGHTS AT 50 Hz, 2 POLES

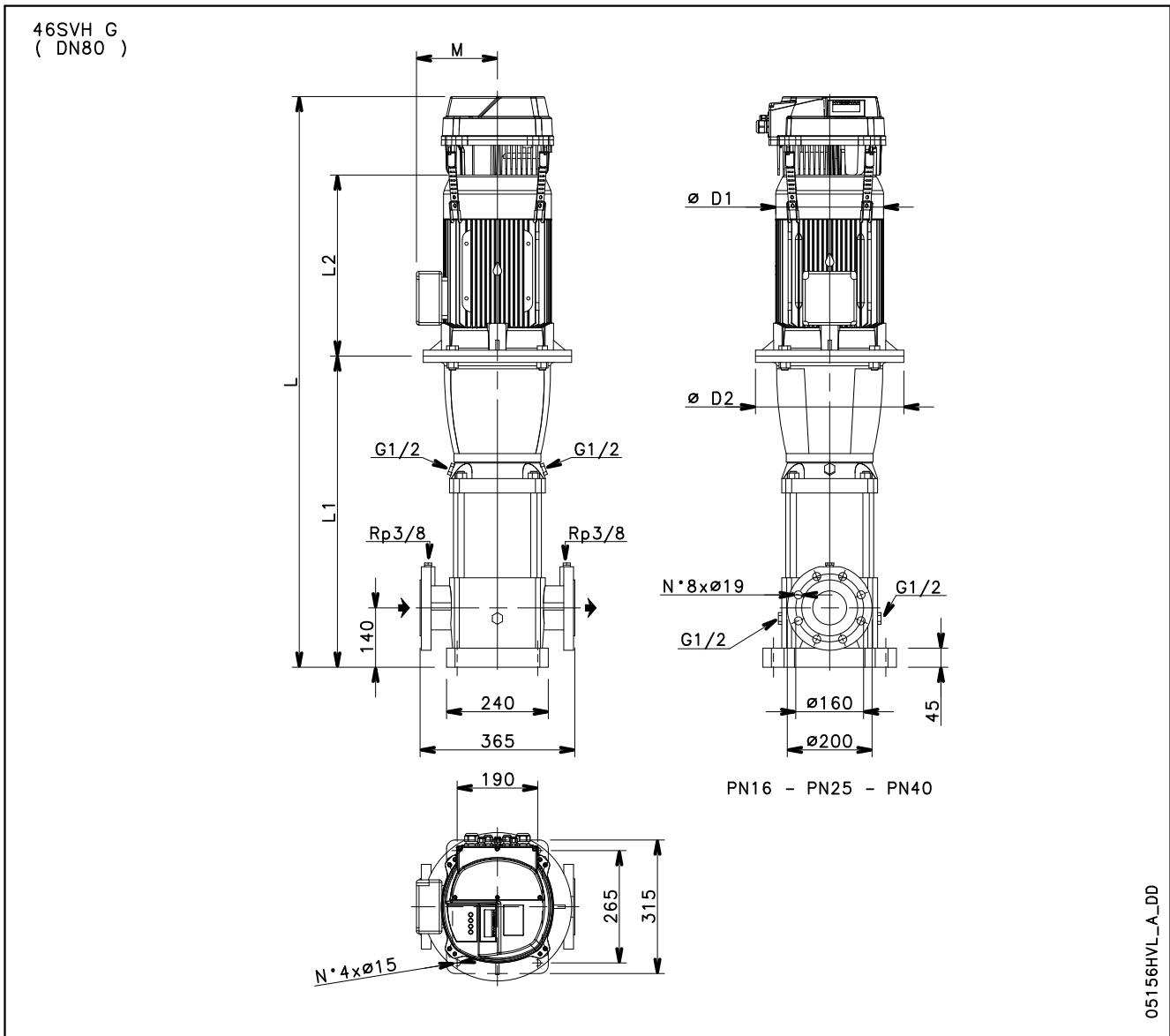

PUMP TYPE	MOTOR		DIMENSIONS (mm)						WEIGHT (kg)					
									L			WEIGHT (kg)		
									/2	/3	/4	/2	/3	/4
	kW	SIZE	L1	L2	D1	D2	M	PN	1~230V	3~230V	3~400V	1~230V	3~230V	3~400V
46SVH1	4	112	529	319	197	164	154	16	1033	1033	1018	95,0	95,0	90,1
46SVH2	7,5	132	624	367	256	300	191	16	-	1191	1176	-	137,6	132,5
46SVH3	11	160	734	428	256	350	191	16	-	1362	1347	-	159,6	154,5
46SVH4	15	160	809	494	313	350	240	16	-	-	1503	-	-	195,6
46SVH6	22	180	959	494	313	350	240	25	-	-	1653	-	-	223,6

46SVH SERIES OPERATING CHARACTERISTICS AT 30..50 Hz

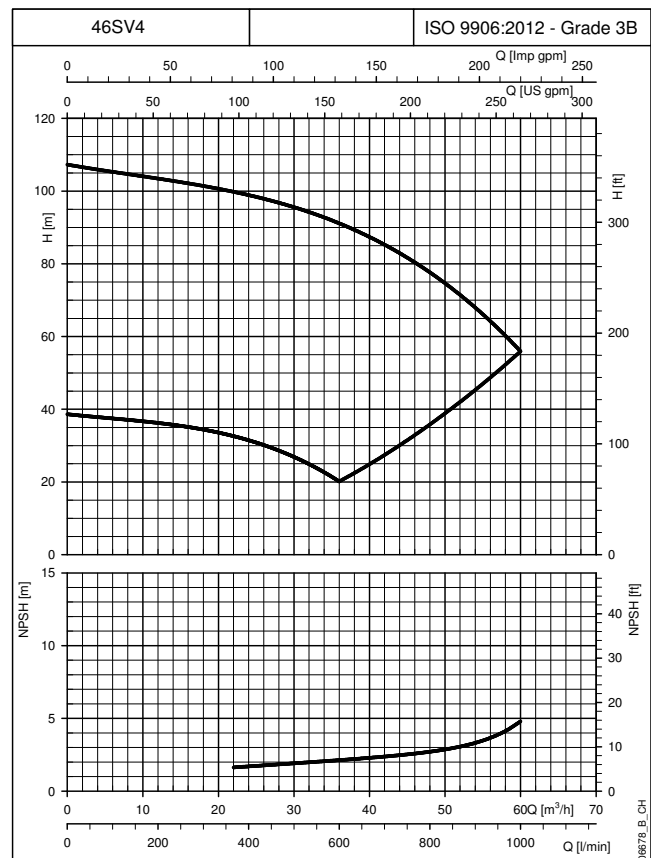
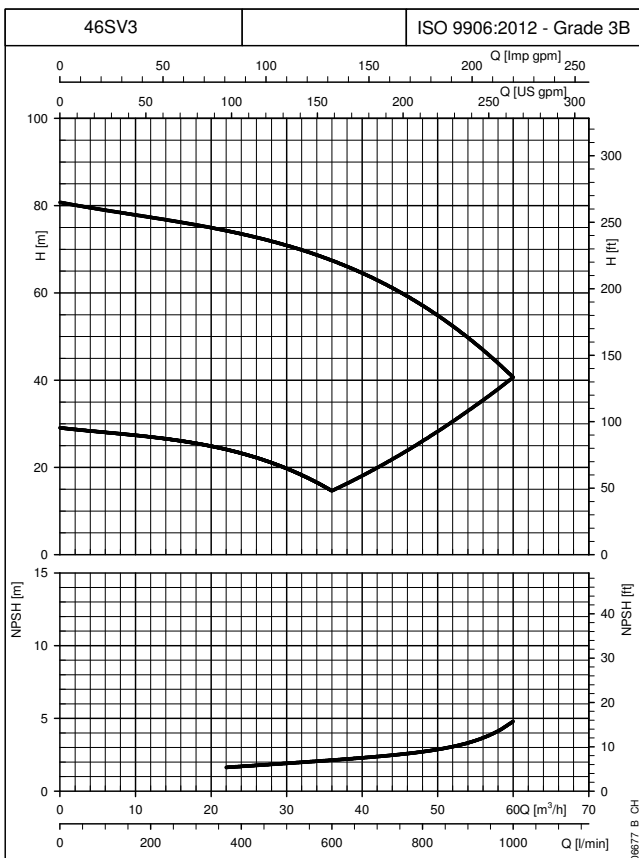
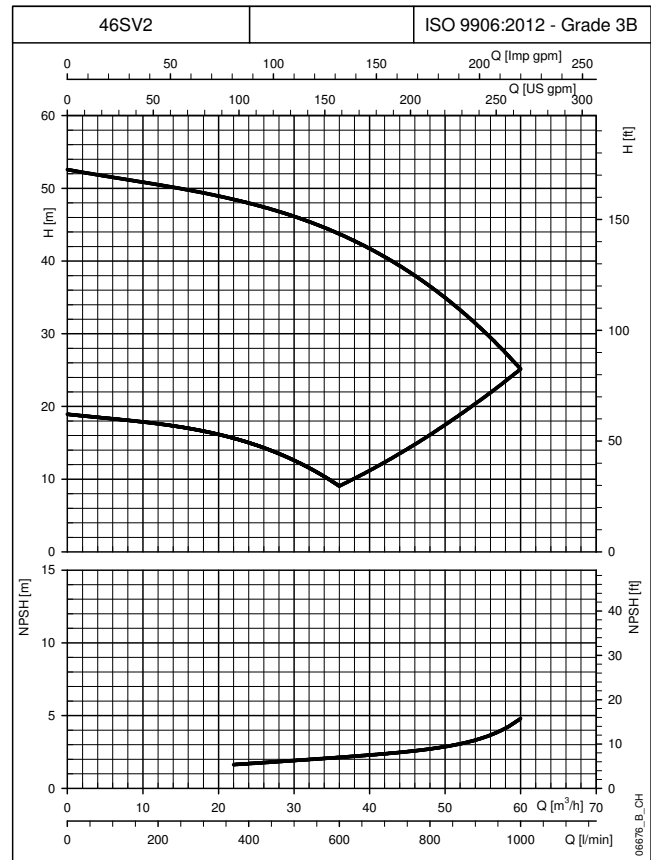
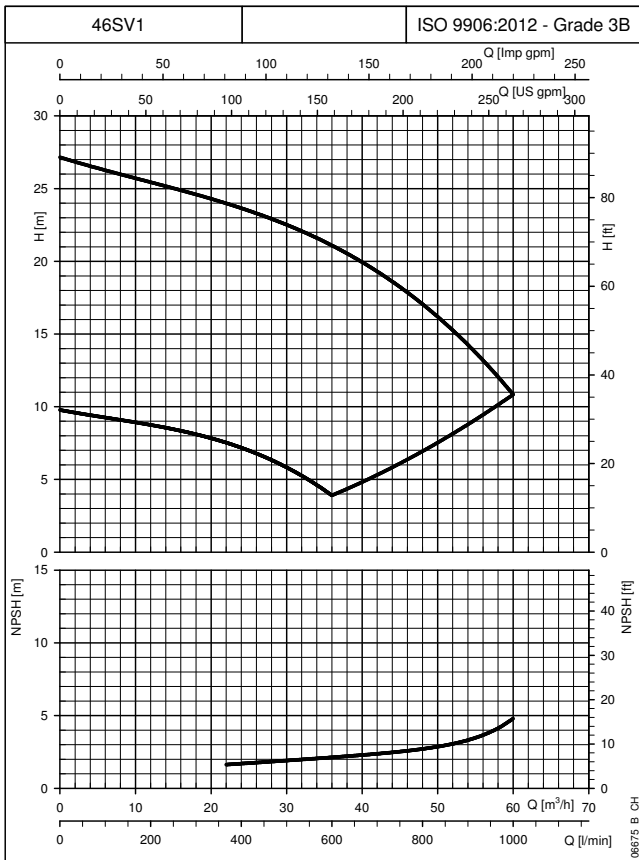

The curves show the performance with one pump running to the minimum and maximum speed. These performances are valid for liquids with density $\rho = 1.0 \text{ Kg/dm}^3$ and kinematic viscosity $\nu = 1 \text{ mm}^2/\text{s}$.

**46SVH SERIES
OPERATING CHARACTERISTICS AT 30..50 Hz**

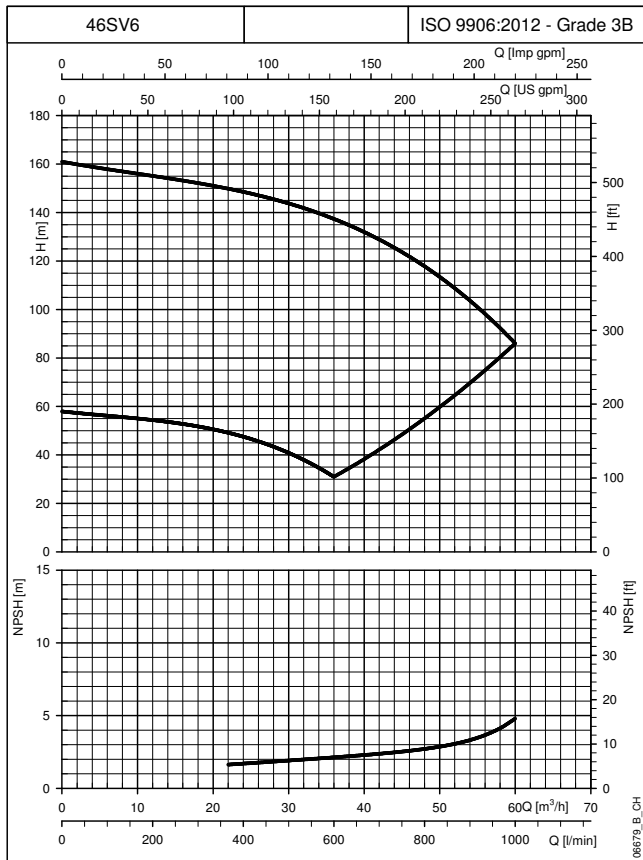

The curves show the performance with one pump running to the minimum and maximum speed.
These performances are valid for liquids with density $\rho = 1.0 \text{ Kg/dm}^3$ and kinematic viscosity $\nu = 1 \text{ mm}^2/\text{s}$.

66SVH SERIES DIMENSIONS AND WEIGHTS AT 50 Hz, 2 POLES

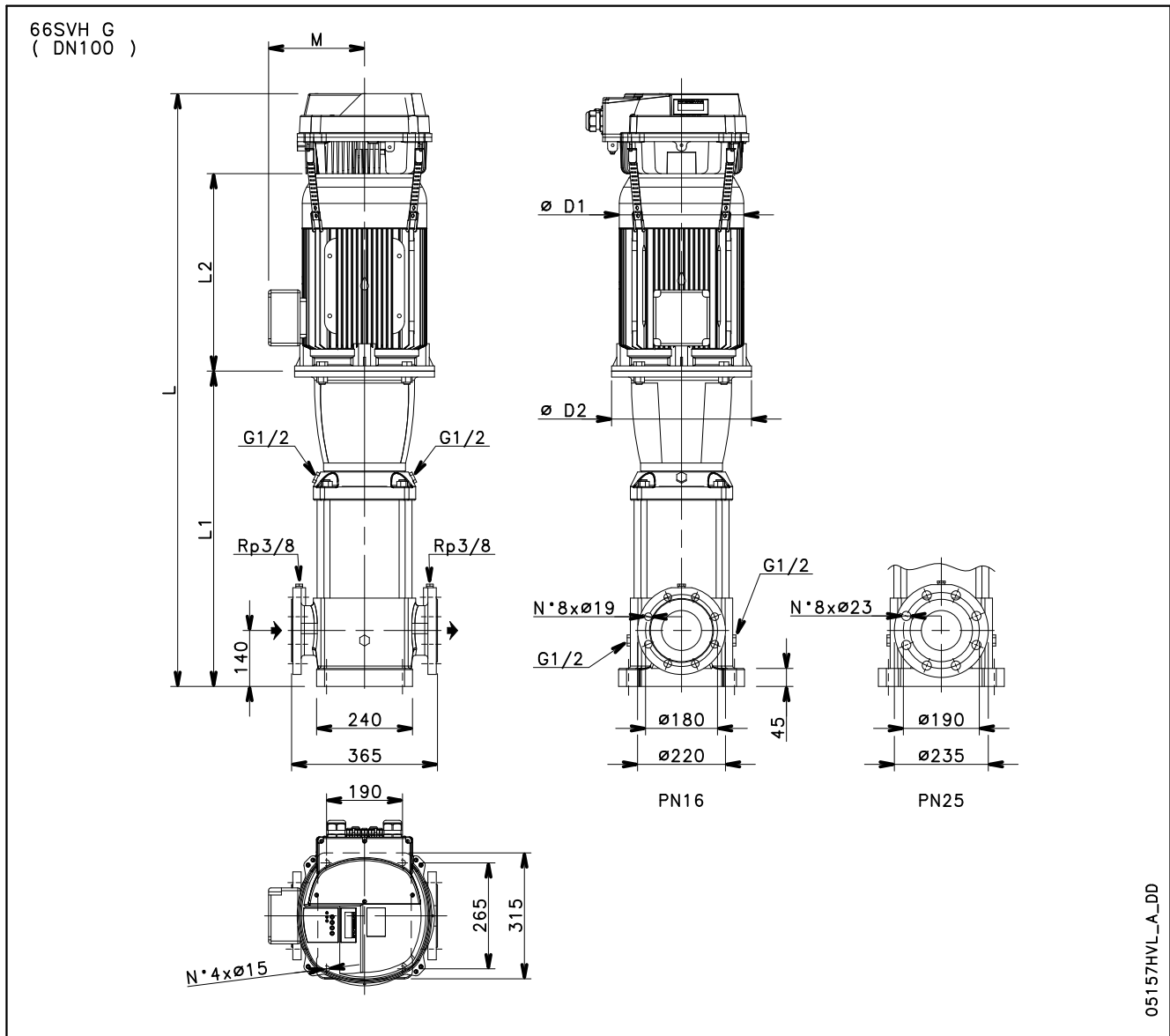

PUMP TYPE	MOTOR		DIMENSIONS (mm)						WEIGHT (kg)					
									L			WEIGHT (kg)		
									/2	/3	/4	/2	/3	/4
	kW	SIZE	L1	L2	D1	D2	M	PN	1~230V	3~230V	3~400V	1~230V	3~230V	3~400V
66SVH1	5,5	132	574	375	214	300	168	16	-	1134	1134	-	120,5	120,5
66SVH2	11	160	699	428	256	350	191	16	-	1327	1312	-	166,6	161,5
66SVH3	18,5	160	789	494	313	350	240	16	-	-	1483	-	-	212,6
66SVH4	22	180	879	494	313	350	240	16	-	-	1573	-	-	229,6

66SVH SERIES OPERATING CHARACTERISTICS AT 30..50 Hz

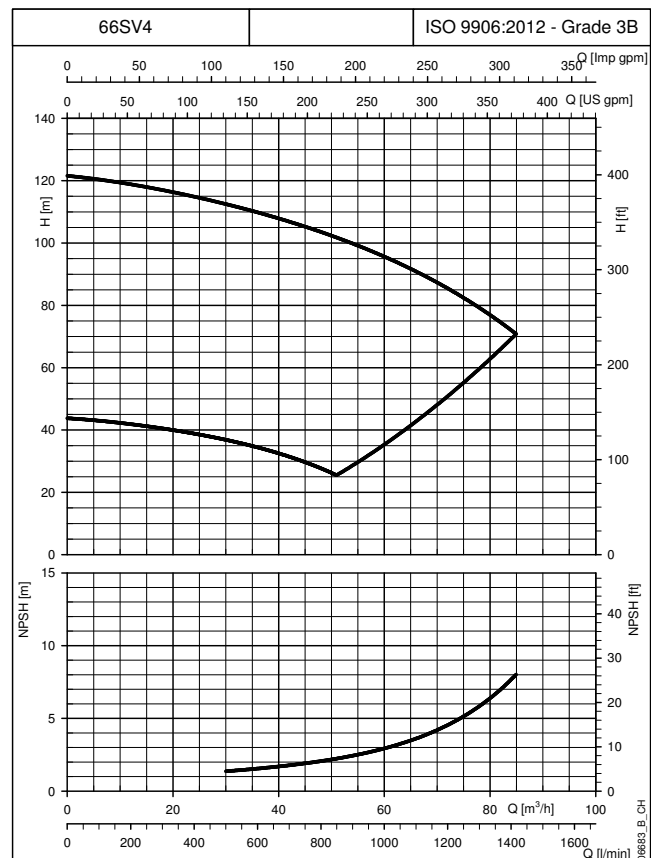
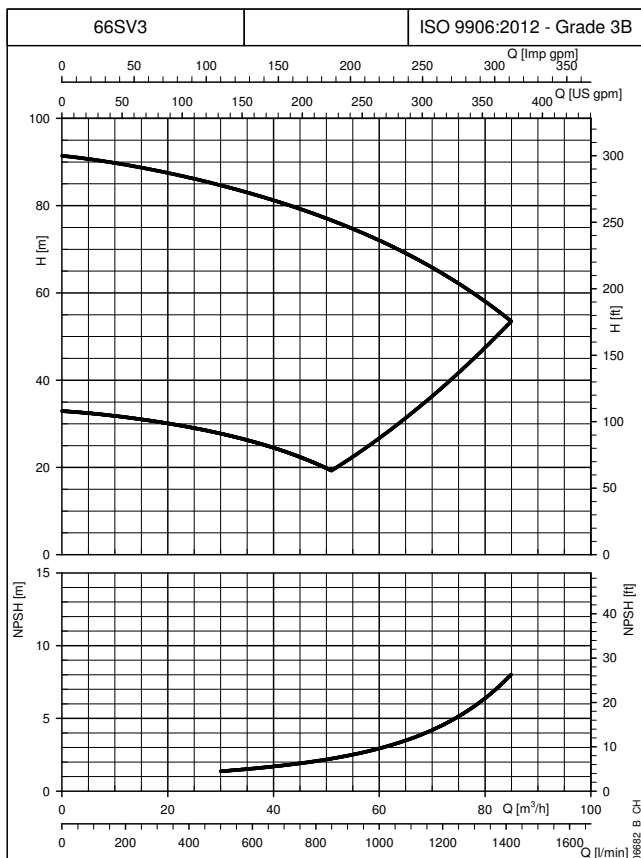
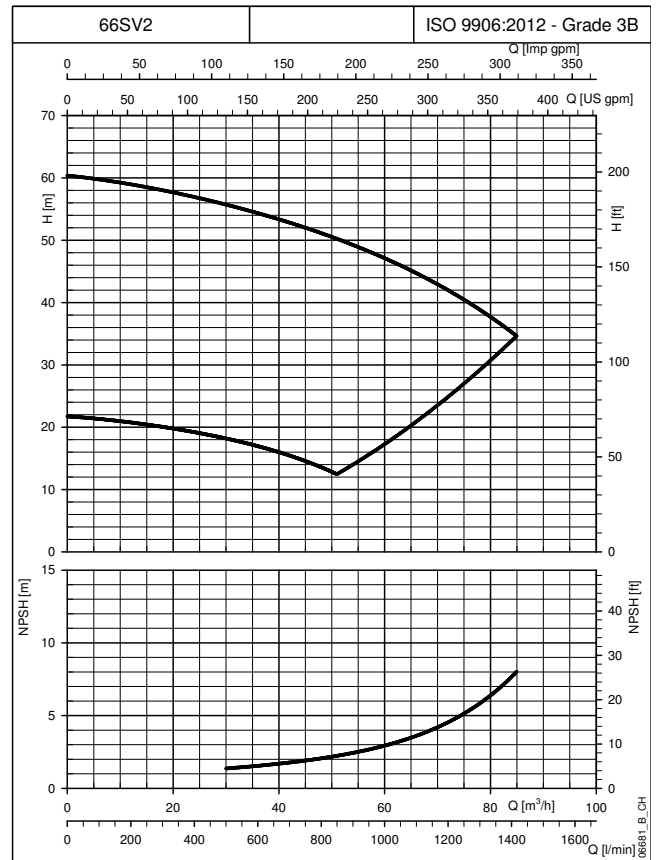
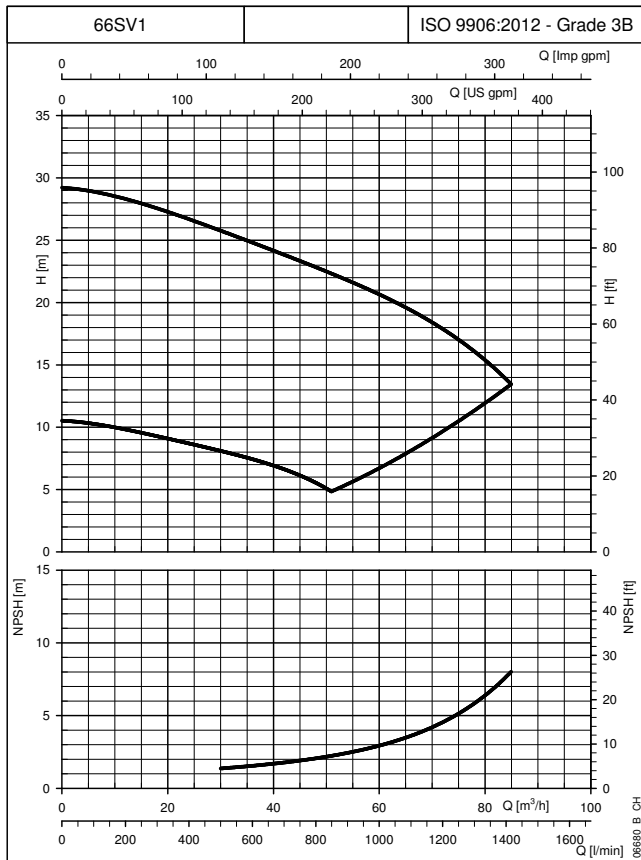

The curves show the performance with one pump running to the minimum and maximum speed. These performances are valid for liquids with density $\rho = 1.0 \text{ Kg/dm}^3$ and kinematic viscosity $\nu = 1 \text{ mm}^2/\text{s}$.

92SVH SERIES
DIMENSIONS AND WEIGHTS AT 50 Hz, 2 POLES

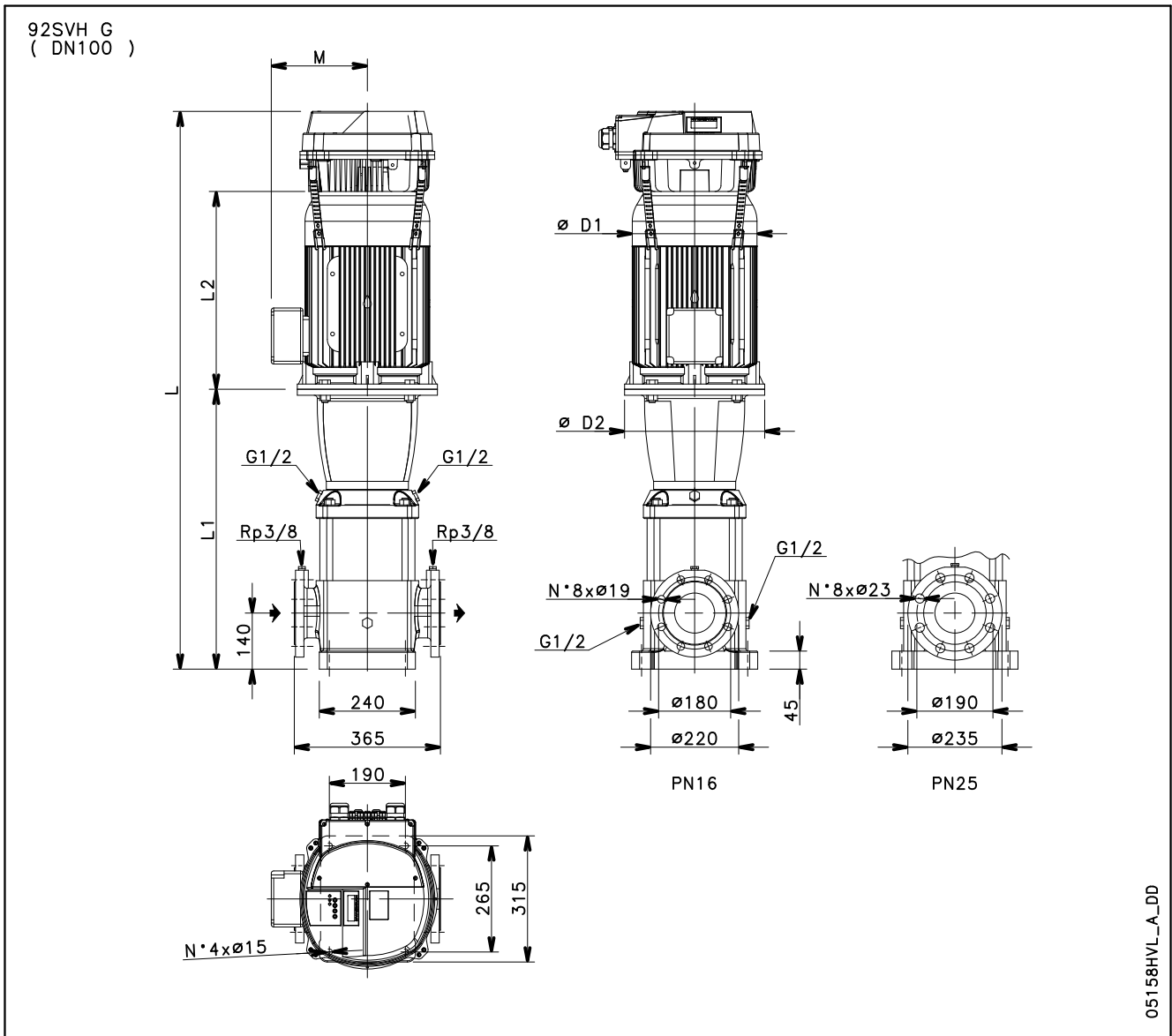

PUMP TYPE	MOTOR		DIMENSIONS (mm)						L			WEIGHT (kg)		
									/2	/3	/4	/2	/3	/4
									1~230V	3~230V	3~400V	1~230V	3~230V	3~400V
92SVH1	7,5	132	574	367	256	300	191	16	-	1141	1126	-	142,6	137,5
92SVH2	15	160	699	494	313	350	240	16	-	-	1393	-	-	197,6
92SVH3	22	180	789	494	313	350	240	16	-	-	1483	-	-	223,6

92SVH SERIES OPERATING CHARACTERISTICS AT 30..50 Hz

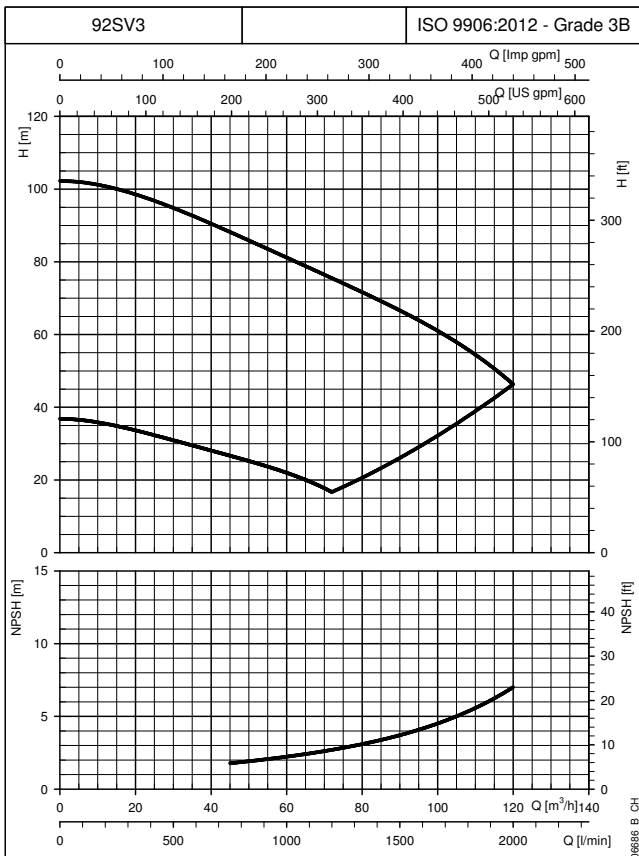
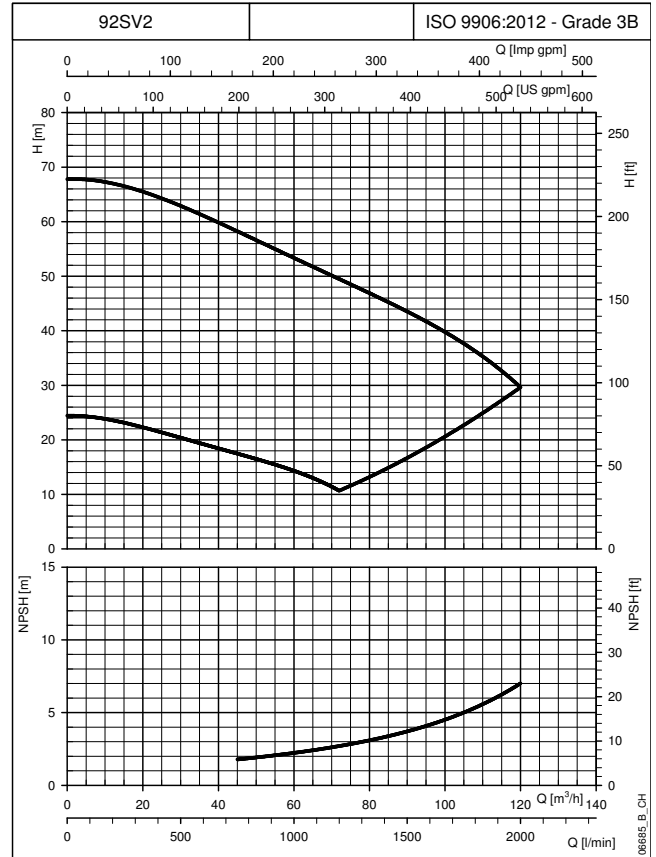
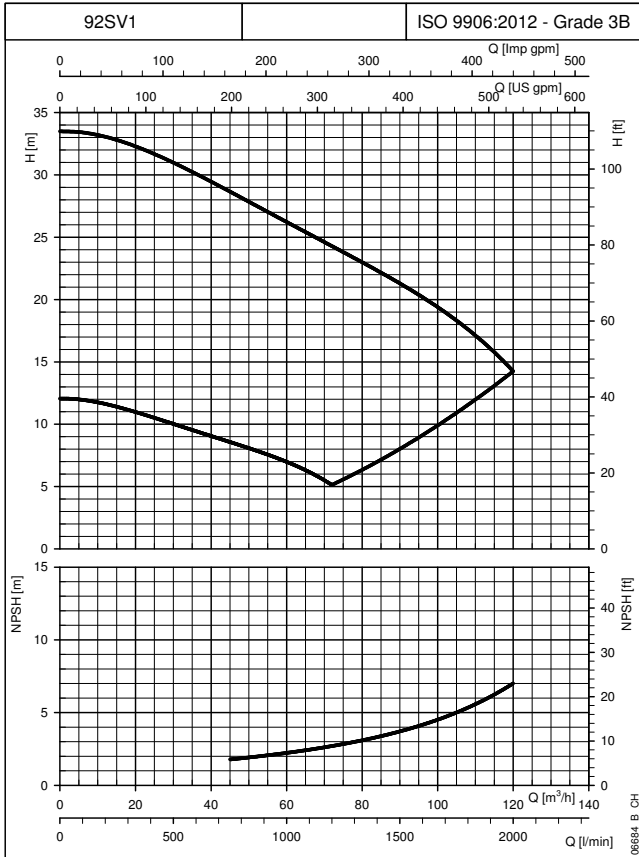

The curves show the performance with one pump running to the minimum and maximum speed. These performances are valid for liquids with density $\rho = 1.0 \text{ Kg/dm}^3$ and kinematic viscosity $\nu = 1 \text{ mm}^2/\text{s}$.

125SVH SERIES DIMENSIONS AND WEIGHTS AT 50 Hz, 2 POLES

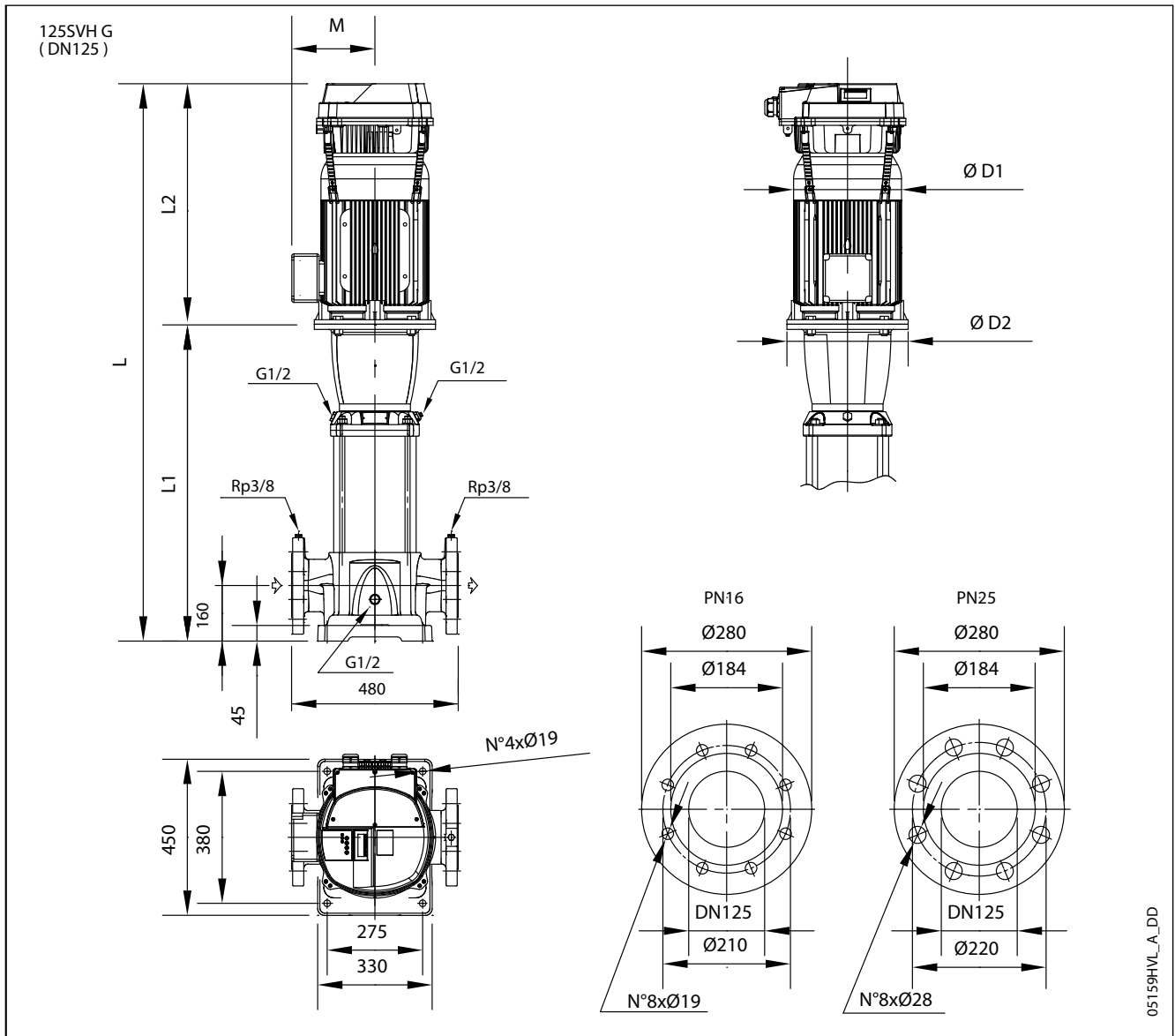

PUMP TYPE	MOTOR		DIMENSIONS (mm)						L			WEIGHT (kg)		
									/2	/3	/4	/2	/3	/4
									1 ~ 230V	3 ~ 230V	3 ~ 400V	1 ~ 230V	3 ~ 230V	3 ~ 400V
125svH1	7,5	132	693	367	256	300	191	16	-	1260	1245	-	187,6	183
125svH2	15	160	787	494	313	350	240	16	-	-	1481	-	-	249
125svH3	22	180	1028	494	313	350	240	16	-	-	1722	-	-	281

125SVH SERIES OPERATING CHARACTERISTICS AT 30..50 Hz

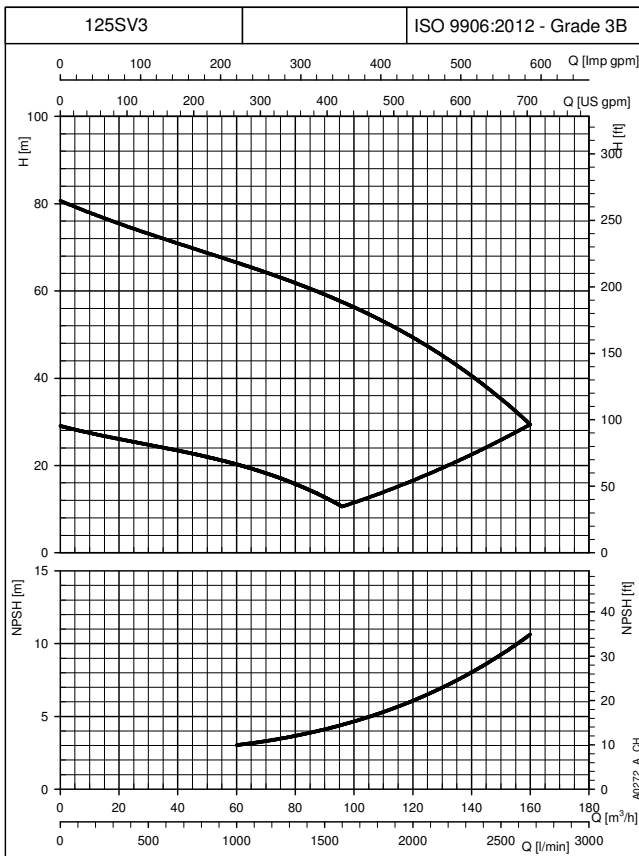
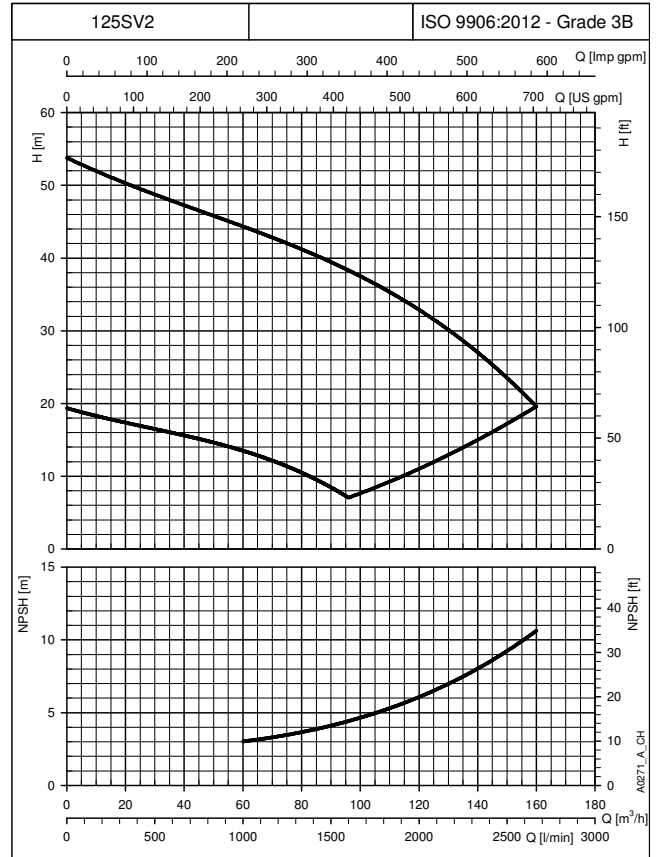
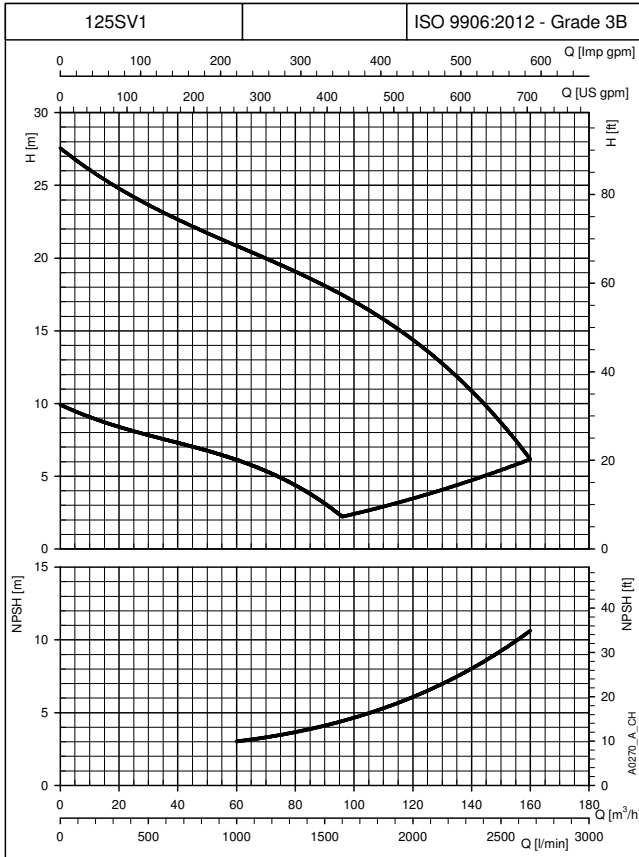

The curves show the performance with one pump running to the minimum and maximum speed. These performances are valid for liquids with density $\rho = 1.0 \text{ Kg/dm}^3$ and kinematic viscosity $\nu = 1 \text{ mm}^2/\text{s}$.

**e-SVE:
VERSION WITH DRIVE
AND PERMANENT
MAGNET MOTOR
(e-SM DRIVE)**

e-SVE SERIES (e-SV SMART)

Background and context

In every sector, from construction and industry to agriculture and building services the need for intelligent, compact and high-efficiency pumping systems is constantly growing.

That's why Lowara has developed the e-SV Smart series: an integrated intelligent pumping system with electronically driven, permanent magnet motor (IE5 efficiency level).

The integrated control system, combined with the high performance, power and efficiency from the motor and hydraulics, guarantees impressively low operating costs. You also benefit from flexibility, precision and its ultra-compact size.

Savings

The electronics and permanent magnet motor are highly efficient and minimize power losses while transferring maximum energy to the hydraulic parts of the pump.

The refined control system with integrated microprocessor adjusts the motor speed, matching the required operating point of the pump or system requirements.

This reduces demand on electricity according to the required working conditions.

This creates economies, especially in systems where pump demand varies over time.

Flexibility

The compact size, low loss and increased control make the e-SV Smart series a good choice in applications and systems where fixed speed pumps are commonly used. The e-SV Smart series is easy to integrate in control and regulation loops thanks to the wide availability of compatible communication protocols, including analog and digital inputs.

The pump is supplied with a pressure sensor.

Ease of use and commissioning

e-SV Smart has an intuitive interface that guides the user through the installation, and a practical area to assist with connections.

The control system is integrated and no additional external electrical panel is required

Application sectors

- Water supply systems in residential buildings
- Air conditioning
- Water treatment plants
- Industrial installations

Identification code

The electrical voltage supply of e-SVE models is identified by the last characters.

Example: 22SVE02F015POM/2

M/2 = 1x208-240 V

T/4 = 3x380-460 V

T/5 = 3x208-240/380-460 V

e-SM system

- Single-phase power supply:
208-240 V +/- 10%, 50/60 Hz
- Three-phase power supply:
 - from 0,37 kW to 1,5 kW:
208-240 / 380-460 V +/- 10%, 50/60 Hz
 - 2,2 kW: 380-460 V +/- 10%, 50/60 Hz
- Power up to 2,2kW
- Protection class IP 55
- Can be linked up to 3 e-SV Smart pumps



Pump

- Flow rate: up to 30 m³/h
- Head: up to 235 m
- Temperature of pumped liquid: up to +120°C
- Maximum operating pressure 25 bar (PN 25)
- The hydraulic performances meet the tolerances specified in ISO 9906:2012.
- Environment temperature: -20° C to +50° C with no performance derating

Motor

- IE5 efficiency level (IEC TS 60034-30-2:2016)
- Synchronous electric motor with permanent magnets, closed structure, air-cooled (TEFC)
- Insulation class 155 (F)
- Overload protection and locked rotor with automatic reset incorporated

Regulations (EU) 2019/1781 e 2021/341

Annex I – point 4

(Product information)

The requirements shall not apply to these variable speed drives, as they are integrated to permanent magnet motors, that aren't covered by the same regulations.

e-SVE SERIES (e-SV SMART)

e-SV Smart series is equipped with an intelligent control that optimizes hydraulic performance while minimizing waste.

Integrated intelligence: The electronic control of the motor enables a 20% increase in performance compared to an equivalent fixed speed pump (area highlighted in figure "Integrated intelligence").

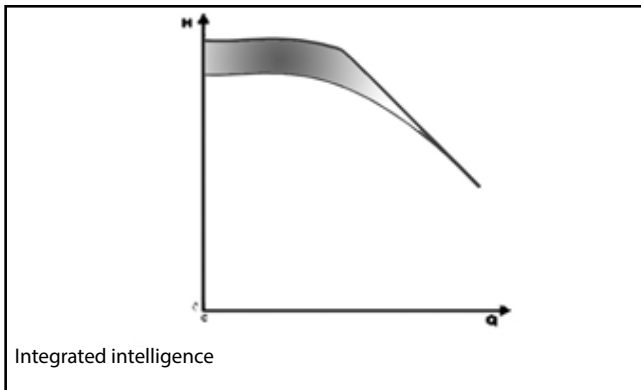

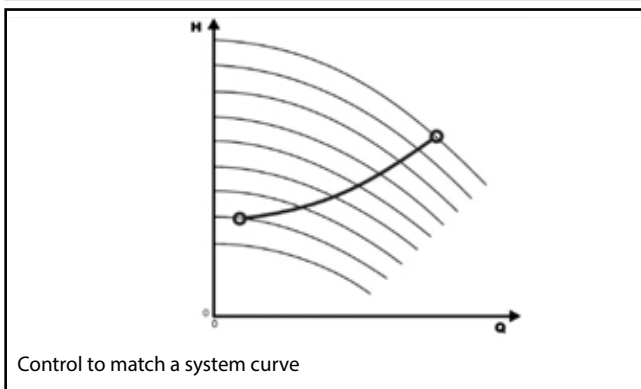
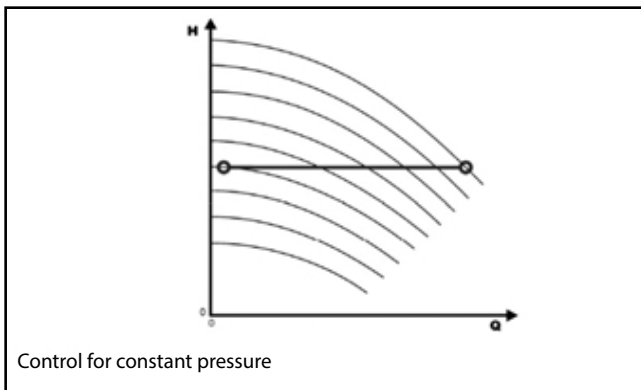

Adjustment: This is possible both at constant pressure and according to the characteristic curve of the system, based on the customer's preferences.

Another option is according to an external signal or at a preset speed.



Intuitive and simple interface: You can control the unit from just three buttons, with an easy to read display for parameters and alarms, designed for complete control of system operation.

- ① Communication LED
- ② Power on LED
- ③ Unit of measure LED
- ④ Speed LED bar
- ⑤ Status LED
- ⑥ Numeric display
- ⑦  Decrease key
- ⑧  On/off and menu key
- ⑨  Increase key

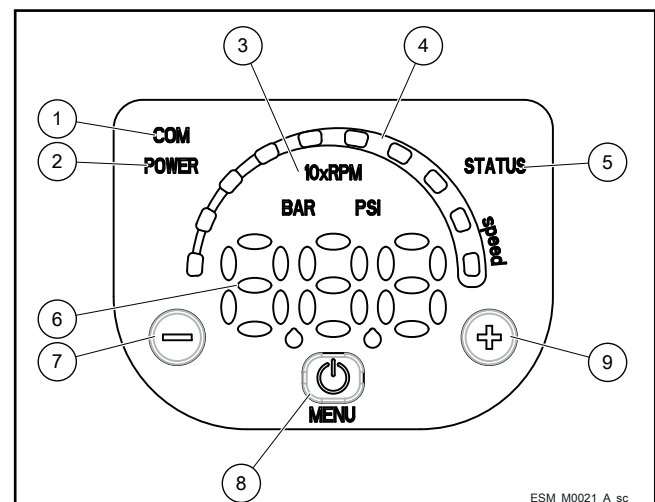

e-SVE SERIES SINGLE PHASE TERMINAL BLOCK

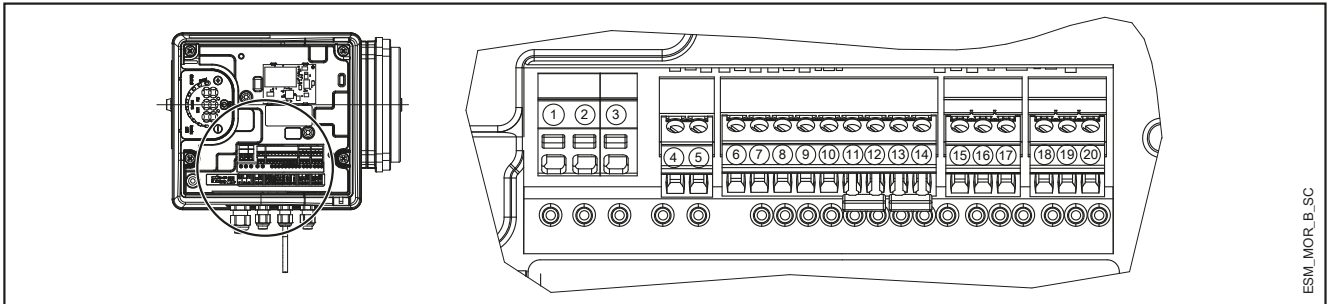

ESM_MOR_B_SC

REF.	ITEM	DESCRIPTION
4	Fault Signal	COM - error status relay
5		NO - error status relay
6	Auxiliary Voltage Supply	Auxiliary voltage supply +15 VDC
7	Analog input 0-10V	Actuator mode 0-10 V input
8		GND for 0-10 V input
9	External Pressure sensor [also Differential]	Power supply external sensor +15 VDC
10		External sensor 4-20 mA input
11	External Start/Stop	External ON/OFF input reference
12		External ON/OFF input
13	External Lack of Water	Low water input
14		Low water reference
15	Communication bus	RS485 port 1: RS485-1N B (-)
16		RS485 port 1: RS485-1P A (+)
17		Electronic GND
18	Communication bus	RS485 port 2: RS485 port 2: RS485-2N B (-) active only with optional module
19		RS485 port 2: RS485 port 2: RS485-2P A (+) active only with optional module
20		Electronic GND

MorsM-en_a_sc

THREE-PHASE TERMINAL BLOCK

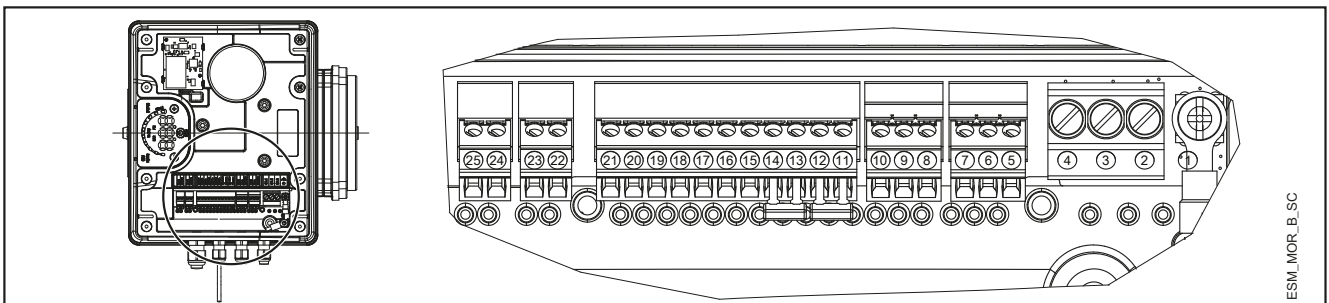

ESM_MOR_B_SC

REF.	ITEM	DESCRIPTION
5	Communication bus	Electronic GND
6		RS485 port 1: RS485-1P A (+)
7	RS485 port 1: RS485-1N B (-)	
8	Communication bus	Electronic GND
9		RS485 port 2: RS485 port 2: RS485-2P A (+) active only with optional module
10	RS485 port 2: RS485 port 2: RS485-2N B (-) active only with optional module	
11	External Lack of Water	Low water reference
12		Low water input
13	External Start/Stop	External ON/OFF input reference
14		External ON/OFF input
15	External Pressure sensor	External sensor 4-20 mA input
16		Power supply external sensor +15 VDC
17	External Pressure sensor [also Differential]	External sensor 4-20 mA input
18		Power supply external sensor +15 VDC
19	Analog input 0-10V	GND for 0-10 V input
20		Actuator mode 0-10 V input
21	Auxiliary Voltage Supply	Auxiliary voltage supply +15 VDC
22	Motor running signal	Normally open contact
23		Common contact
24	Fault Signal	NO - error status relay
25		COM - error status relay

MorsT-en_a_sc

e-SVE SERIES
HOW TO READ SMART PUMP SERIES CURVES

To exploit to the maximum potential of Smart Pumps it's important to properly read working curves:

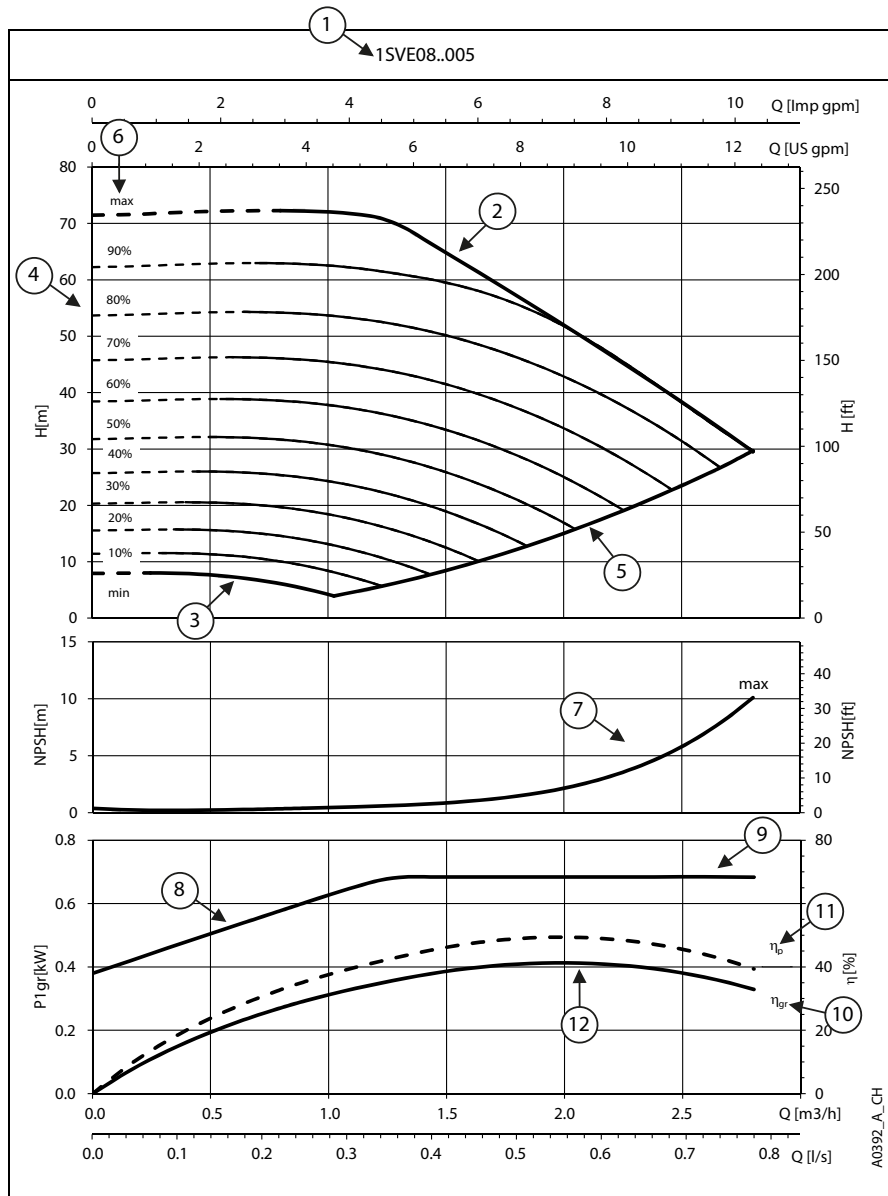

① **Pump model**

② **Maximum speed curve:** equal to 3600 rpm

③ **Minimum speed curve:** it refers to the minimum rpm level the motor can work at, it's calculated depending on the model of pump maximizing for each one the working area and allowing the highest system flexibility.

④ The **area with dotted lines** is where the pump can only operate intermittently for short periods of time.

⑤ Each **intermediate curve** between max and min speed shows the percentage of load the pump+motor+drive system is working at; it's easy to read also from the LED speed bar on the HMI keypad: at 90% there will be 9 led, at 80% there will be 8 and so on.

Example: at 60% there will be 6 lit led's

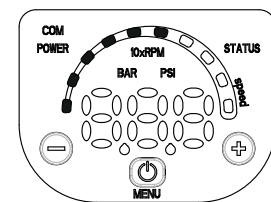

⑥ The **part load percentage** is calculated depending on maximum speed (*max*, 100%) and minimum speed (*min*, equal to 0%, which is the minimum part load step, below it the drive stays powered up but cannot work).

⑦ **NPSH**: is the net positive suction head of pump+motor+drive system working at maximum speed.

⑧ **P1_{gr}** is the power absorption in kW of pump+motor+drive system working at maximum speed.

⑨ **Load control**: the Smart Pump controls and limits power consumption at high flow/low head, in this way the motor stays protected from overload and ensure a longer life of pump+motor+drive system.

⑩ **η_{gr}** is the efficiency of pump+motor+drive system working at maximum speed.

⑪ **η_p** is the efficiency of the hydraulic part, working at maximum speed.

⑫ **Working point**: it's important to make sure the pump is working at the best working point, the one at highest efficiency.

It's easy to find it: it's the highest point of the hp pump efficiency curve; once you found it, you can learn also flow values from x-axis called Q and head values from y-axis called H which allow the system to work at the best working point.

e-SVE SERIES - SINGLE PHASE VERSION HYDRAULIC PERFORMANCES TABLE

PUMP TYPE SVE Single-phase	MOTOR		e-SM SET		Q = DELIVERY							
	P _N kW	TYPE 1x230 V	* P ₁ kW	* I 208-240 V A	l/min 0	6,7	13,3	20,0	26,7	33,3	40,0	46,7
					m ³ /h 0	0,4	0,8	1,2	1,6	2,0	2,4	2,8
H = TOTAL HEAD IN METRES OF COLUMN OF WATER												
1SVE05..003POM	0,37	ESM90R/103 SVE	0,49	2,24	44,7	45,0	45,2	44,6	41,5	35,0	28,1	20,8
1SVE08..005POM	0,55	ESM90R/105 SVE	0,68	3,07	71,5	72,0	72,3	71,2	62,3	52,0	41,2	29,6
1SVE11..007POM	0,75	ESM90R/107 SVE	0,91	4,04	98,3	99,1	99,3	97,7	85,1	70,9	56,0	40,0
1SVE15..011POM	1,1	ESM90R/111 SVE	1,33	5,85	134,1	135,1	135,5	133,8	123,6	103,9	83,3	61,4
1SVE20..015POM	1,5	ESM90R/115 SVE	1,78	7,79	178,9	180,1	180,6	178,5	168,0	141,6	114,0	84,7

PUMP TYPE SVE Single-phase	MOTOR		e-SM SET		Q = DELIVERY							
	P _N kW	TYPE 1x230 V	* P ₁ kW	* I 208-240 V A	l/min 0	13,3	26,7	40,0	53,3	66,7	80,0	86,7
					m ³ /h 0	0,8	1,6	2,4	3,2	4,0	4,8	5,2
H = TOTAL HEAD IN METRES OF COLUMN OF WATER												
3SVE03..003POM	0,37	ESM90R/103 SVE	0,49	2,24	33,4	33,7	33,6	30,7	24,9	19,5	14,0	10,9
3SVE05..005POM	0,55	ESM90R/105 SVE	0,69	3,08	55,7	56,2	55,8	46,3	37,1	28,4	19,5	14,4
3SVE07..007POM	0,75	ESM90R/107 SVE	0,92	4,06	77,9	78,7	77,2	63,4	50,7	38,6	26,0	18,7
3SVE09..011POM	1,1	ESM90R/111 SVE	1,33	5,85	100,2	101,0	100,5	88,8	72,5	56,4	39,9	31,2
3SVE11..015POM	1,5	ESM90R/115 SVE	1,78	7,80	122,5	123,3	122,5	117,9	98,4	78,0	57,2	46,3

PUMP TYPE SVE Single-phase	MOTOR		e-SM SET		Q = DELIVERY							
	P _N kW	TYPE 1x230 V	* P ₁ kW	* I 208-240 V A	l/min 0	23,3	46,7	70,0	93,3	116,7	140,0	166,7
					m ³ /h 0	1,4	2,8	4,2	5,6	7,0	8,4	10,0
H = TOTAL HEAD IN METRES OF COLUMN OF WATER												
5SVE02..003POM	0,37	ESM90R/103 SVE	0,49	2,24	22,4	22,2	21,8	20,0	16,5	13,3	10,2	6,5
5SVE03..005POM	0,55	ESM90R/105 SVE	0,68	3,07	33,5	33,3	32,7	29,8	24,5	19,8	15,2	9,5
5SVE04..007POM	0,75	ESM90R/107 SVE	0,91	4,05	44,7	44,4	43,5	40,5	33,4	27,1	20,8	13,3
5SVE06..011POM	1,1	ESM90R/111 SVE	1,33	5,86	67,1	66,6	65,3	59,5	49,0	39,6	30,4	19,1
5SVE08..015POM	1,5	ESM90R/115 SVE	1,78	7,81	88,8	89,3	87,6	82,6	68,3	55,3	42,6	27,9

PUMP TYPE SVE Single-phase	MOTOR		e-SM SET		Q = DELIVERY							
	P _N kW	TYPE 1x230 V	* P ₁ kW	* I 208-240 V A	l/min 0	40,0	80,0	120,0	160,0	200,0	240,0	283,3
					m ³ /h 0	2,4	4,8	7,2	9,6	12,0	14,4	17,0
H = TOTAL HEAD IN METRES OF COLUMN OF WATER												
10SVE01..005POM	0,55	ESM90R/105 SVE	0,68	3,07	17,3	17,3	16,9	16,2	13,6	10,4	7,1	3,3
10SVE02..007POM	0,75	ESM90R/107 SVE	0,92	4,09	24,2	23,9	23,1	21,7	19,3	14,6	9,7	3,6
10SVE02..011POM	1,1	ESM90R/111 SVE	1,33	5,85	34,8	34,5	33,7	32,3	27,7	22,4	17,1	11,0
10SVE03..015POM	1,5	ESM90R/115 SVE	1,78	7,81	52,7	52,2	51,0	46,1	38,1	30,8	23,5	15,1

PUMP TYPE SVE Single-phase	MOTOR		e-SM SET		Q = DELIVERY							
	P _N kW	TYPE 1x230 V	* P ₁ kW	* I 208-240 V A	l/min 0	70,0	140,0	210,0	280,0	350,0	420,0	483,3
					m ³ /h 0	4,2	8,4	12,6	16,8	21,0	25,2	29,0
H = TOTAL HEAD IN METRES OF COLUMN OF WATER												
15SVE01..007POM	0,75	ESM90R/107 SVE	0,92	4,10	14,2	13,9	13,3	12,3	9,8	6,4	2,8	
15SVE01..011POM	1,1	ESM90R/111 SVE	1,33	5,85	20,5	20,1	19,4	18,4	14,8	10,9	7,0	3,2
15SVE02..015POM	1,5	ESM90R/115 SVE	1,76	7,71	29,6	29,1	28,3	26,8	22,2	16,4	10,1	3,8

PUMP TYPE SVE Single-phase	MOTOR		e-SM SET		Q = DELIVERY							
	P _N kW	TYPE 1x230 V	* P ₁ kW	* I 208-240 V A	l/min 0	70,0	140,0	210,0	280,0	350,0	420,0	500,0
					m ³ /h 0	4,2	8,4	12,6	16,8	21,0	25,2	30,0
H = TOTAL HEAD IN METRES OF COLUMN OF WATER												
22SVE01..007POM	0,75	ESM90R/107 SVE	0,89	3,95	14,4	14,4	14,1	12,5	9,5	6,3	2,9	
22SVE01..011POM	1,1	ESM90R/111 SVE	1,34	5,87	20,7	20,8	20,5	18,7	15,1	11,5	7,8	3,2
22SVE02..015POM	1,5	ESM90R/115 SVE	1,72	7,56	31,4	31,0	30,3	26,7	21,7	16,7	11,0	2,8

* Maximum value in specified range: P₁ = input power; I = input current.

1-22sve-esm-2p50-en_a_th

e-SVE SERIES - THREE PHASE VERSION HYDRAULIC PERFORMANCES TABLE

PUMP TYPE SVE Three-phase	MOTOR		e-SM SET		Q = DELIVERY								
	PN kW	TYPE	* P1 kW	* I	* I	l/min 0	6,7	13,3	20,0	26,7	33,3	40,0	46,7
				208-240 V A	380-460 V A	m3/h 0	0,4	0,8	1,2	1,6	2,0	2,4	2,8
1SVE05..03T..	0,37	ESM90R/303 SVE	0,49	2,14	1,45	44,7	45,0	45,2	44,6	41,5	34,9	28,0	20,8
1SVE08..05T..	0,55	ESM90R/305 SVE	0,69	2,81	1,90	71,5	72,0	72,3	71,2	62,4	52,1	41,2	29,7
1SVE11..07T..	0,75	ESM90R/307 SVE	0,91	3,55	2,40	98,3	99,1	99,3	97,7	85,0	70,9	56,0	40,1
1SVE15..11T..	1,1	ESM90R/311 SVE	1,37	4,94	3,45	134,1	135,1	135,5	133,8	123,6	104,0	83,3	61,4
1SVE20..15T..	1,5	ESM90R/315 SVE	1,82	6,34	4,41	178,9	180,1	180,6	178,4	168,1	141,7	114,0	84,7
1SVE26..22T04	2,2	ESM90R/322 SVE	2,53	-	5,85	232,5	234,0	235,0	231,6	222,2	204,4	170,0	130,7

PUMP TYPE SVE Three-phase	MOTOR		e-SM SET		Q = DELIVERY								
	PN kW	TYPE	* P1 kW	* I	* I	l/min 0	13,3	26,7	40,0	53,3	66,7	80,0	86,7
				208-240 V A	380-460 V A	m3/h 0	0,8	1,6	2,4	3,2	4,0	4,8	5,2
3SVE03..03T..	0,37	ESM90R/303 SVE	0,49	2,14	1,47	33,4	33,8	33,6	30,7	24,9	19,5	14,0	10,9
3SVE05..05T..	0,55	ESM90R/305 SVE	0,70	2,81	1,92	55,7	56,2	55,8	46,3	37,1	28,4	19,4	14,4
3SVE07..07T..	0,75	ESM90R/307 SVE	0,93	3,55	2,43	77,9	78,7	77,2	63,3	50,6	38,6	26,0	18,7
3SVE09..11T..	1,1	ESM90R/311 SVE	1,37	4,96	3,45	100,2	101,0	100,5	88,8	72,5	56,4	39,9	31,2
3SVE11..15T..	1,5	ESM90R/315 SVE	1,82	6,35	4,42	122,5	123,3	122,5	117,9	98,4	77,9	57,2	46,4
3SVE17..22T04	2,2	ESM90R/322 SVE	2,54	-	5,87	189,8	191,6	190,4	183,4	151,3	119,6	87,4	70,6

PUMP TYPE SVE Three-phase	MOTOR		e-SM SET		Q = DELIVERY								
	PN kW	TYPE	* P1 kW	* I	* I	l/min 0	23,3	46,7	70,0	93,3	116,7	140,0	166,7
				208-240 V A	380-460 V A	m3/h 0	1,4	2,8	4,2	5,6	7,0	8,4	10,0
5SVE02..03T..	0,37	ESM90R/303 SVE	0,50	2,13	1,48	22,4	22,2	21,8	20,0	16,5	13,3	10,2	6,5
5SVE03..05T..	0,55	ESM90R/305 SVE	0,69	2,80	1,92	33,5	33,3	32,7	29,8	24,5	19,8	15,2	9,5
5SVE04..07T..	0,75	ESM90R/307 SVE	0,92	3,55	2,42	44,7	44,4	43,5	40,5	33,4	27,0	20,8	13,3
5SVE06..11T..	1,1	ESM90R/311 SVE	1,38	4,96	3,46	67,1	66,6	65,3	59,5	49,0	39,6	30,3	19,1
5SVE08..15T..	1,5	ESM90R/315 SVE	1,83	6,38	4,43	88,8	89,2	87,6	82,7	68,4	55,3	42,7	28,0
5SVE12..22T04	2,2	ESM90R/322 SVE	2,55	-	5,88	133,2	133,7	131,6	121,6	100,4	81,0	62,2	40,3

PUMP TYPE SVE Three-phase	MOTOR		e-SM SET		Q = DELIVERY								
	PN kW	TYPE	* P1 kW	* I	* I	l/min 0	40,0	80,0	120,0	160,0	200,0	240,0	283,3
				208-240 V A	380-460 V A	m3/h 0	2,4	4,8	7,2	9,6	12,0	14,4	17,0
10SVE01..05T..	0,55	ESM90R/305 SVE	0,69	2,81	1,90	17,3	17,3	16,9	16,2	13,6	10,4	7,1	3,3
10SVE02..07T..	0,75	ESM90R/307 SVE	0,94	3,52	2,46	24,2	23,9	23,1	21,7	19,3	14,6	9,7	3,6
10SVE02..11T..	1,1	ESM90R/311 SVE	1,37	4,94	3,45	34,8	34,5	33,7	32,3	27,7	22,4	17,1	11,0
10SVE03..15T..	1,5	ESM90R/315 SVE	1,83	6,38	4,43	52,7	52,2	51,0	46,1	38,1	30,8	23,5	15,1
10SVE04..22T04	2,2	ESM90R/322 SVE	2,54	-	5,86	70,3	69,7	68,1	65,8	57,8	47,5	37,4	25,9

PUMP TYPE SVE Three-phase	MOTOR		e-SM SET		Q = DELIVERY								
	PN kW	TYPE	* P1 kW	* I	* I	l/min 0	70,0	140,0	210,0	280,0	350,0	420,0	483,3
				208-240 V A	380-460 V A	m3/h 0	4,2	8,4	12,6	16,8	21,0	25,2	29,0
15SVE01..07T..	0,75	ESM90R/307 SVE	0,92	4,10	2,48	14,2	13,9	13,3	12,3	9,8	6,4	2,8	0,0
15SVE01..11T..	1,1	ESM90R/311 SVE	1,33	5,85	3,45	20,5	20,1	19,4	18,4	14,8	10,9	7,0	3,2
15SVE02..15T..	1,5	ESM90R/315 SVE	1,76	7,71	4,34	29,6	29,1	28,3	26,8	22,2	16,4	10,1	3,8
15SVE02..22T04	2,2	ESM90R/322 SVE	2,54	-	5,87	42,7	42,0	41,1	39,7	33,4	26,8	20,1	13,5

PUMP TYPE SVE Three-phase	MOTOR		e-SM SET		Q = DELIVERY								
	PN kW	TYPE	* P1 kW	* I	* I	l/min 0	70,0	140,0	210,0	280,0	350,0	420,0	500,0
				208-240 V A	380-460 V A	m3/h 0	4,2	8,4	12,6	16,8	21,0	25,2	30,0
22SVE01..07T..	0,75	ESM90R/307 SVE	0,91	3,31	2,38	14,4	14,4	14,1	12,5	9,5	6,3	2,9	0,0
22SVE01..11T..	1,1	ESM90R/311 SVE	1,38	5,00	3,47	20,7	20,8	20,5	18,7	15,1	11,5	7,8	3,2
22SVE02..15T..	1,5	ESM90R/315 SVE	1,76	6,18	4,31	31,4	31,0	30,3	26,7	21,7	16,7	11,0	2,8
22SVE02..22T04	2,2	ESM90R/322 SVE	2,56	-	5,91	45,2	44,7	44,0	39,3	33,0	27,3	21,4	13,6

* Maximum value in specified range: P1 = input power; I = input current.

1-22sve-esm-2p50T-en_a_th

e-SVE SERIES ELECTRICAL DATA TABLE

In the range 3000-3600 rpm the nominal motor power is guaranteed. Above 3600 rpm it isn't possible work and the motor is automatically limited; below 3000 rpm it works partially load.

SINGLE PHASE VERSION

P _N kW	MOTOR TYPE	IEC SIZE*	Construction Design	SPEED (RPM)** min ⁻¹	INPUT CURRENT I (A) 208-240 V	DATA RELATED TO THE VOLTAGE OF 230V					IES	
						In A	cosφ	Tn Nm	η % 4/4 3/4 2/4			
0,37	ESM90R/103 SVE	90R	V18/B14	3000	2,28-1,99	2,08	0,95	1,18	81,3	79,1	74,3	2
				3600	2,30-2,02	2,10		0,98	80,6	77,5	72,0	
0,55	ESM90R/105 SVE	90R		3000	3,27-2,85	2,96	0,97	1,75	83,3	82,2	78,8	2
				3600	3,27-2,85	2,96		1,46	83,3	81,5	77,5	
0,75	ESM90R/107 SVE	90R		3000	4,43-3,84	4,00	0,98	2,39	83,3	83,3	81,5	2
				3600	4,38-3,79	3,94		1,99	84,5	83,5	80,6	
1,10	ESM90R/111 SVE	90R		3000	6,26-5,35	5,64	0,99	3,50	85,7	85,1	82,7	2
				3600	6,20-5,32	5,63		2,92	85,9	84,6	81,4	
1,50	ESM90R/115 SVE	90R		3000	8,57-7,32	7,69	0,99	4,77	85,6	85,7	84,7	2
				3600	8,42-7,25	7,62		3,98	86,3	85,9	84,0	

* R = Reduced size of motor casing as compared to shaft extension and flange.

eSV_Smart-motm_en_a_te

** The indicated rotational speed are representing the upper and lower limits of the rated power operational speed range.

THREE PHASE VERSION

P _N kW	MOTOR TYPE	IEC SIZE*	Construction Design	SPEED (RPM)** min ⁻¹	INPUT CURRENT I (A) 208-240/380-460 V	DATA RELATED TO THE VOLTAGE OF 400V					IES	
						In A	cosφ	Tn Nm	η % 4/4 3/4 2/4			
0,37	ESM90R/303 SVE	90R	V18/B14	3000	2,01-1,85/1,41-1,28	1,42	0,48	1,18	78,6	75,6	70,1	2
				3600	2,13-1,83/1,43-1,33	1,36		0,98	83,1	80,7	76,1	
0,55	ESM90R/305 SVE	90R		3000	2,81-2,57/1,89-1,69	1,88	0,52	1,75	81,1	79,3	75,5	2
				3600	2,90-2,52/1,90-1,73	1,80		1,46	85,4	83,8	80,6	
0,75	ESM90R/307 SVE	90R		3000	3,70-3,37/2,44-2,17	2,41	0,55	2,39	81,9	81,2	78,6	2
				3600	3,74-3,28/2,43-2,20	2,31		1,99	86,1	85,5	83,1	
1,10	ESM90R/311 SVE	90R		3000	5,12-4,73/3,41-3,01	3,35	0,57	3,50	82,8	81,3	77,7	2
				3600	5,15-4,69/3,45-3,06	3,32		2,92	83,5	81,6	77,6	
1,50	ESM90R/315 SVE	90R		3000	6,73-6,17/4,49-3,95	4,39	0,59	4,77	83,1	82,8	80,6	2
				3600	6,69-6,08/4,48-3,97	4,32		3,98	84,6	83,6	80,8	
2,20	ESM90R/322 SVE	90R		3000	- /6,03-5,32	5,81	0,62	7,00	87,6	87,4	85,9	2
				3600	- /5,93-5,24	5,74		5,84	88,9	88,2	86,3	

* R = Reduced size of motor casing as compared to shaft extension and flange.

eSV_Smart-mott_en_a_te

** The indicated rotational speed are representing the upper and lower limits of the rated power operational speed range.

Note. **IES** refers to the efficiency class for frequency converter + motor systems (known as power transmission systems-PDS) with power between 0.12 kW and 1000 kW and between 100 V and 1000 V, according to the standard **EN 50598-2:2014**.

1, 3, 5SVE..F SERIES - SINGLE PHASE VERSION DIMENSIONS AND WEIGHTS

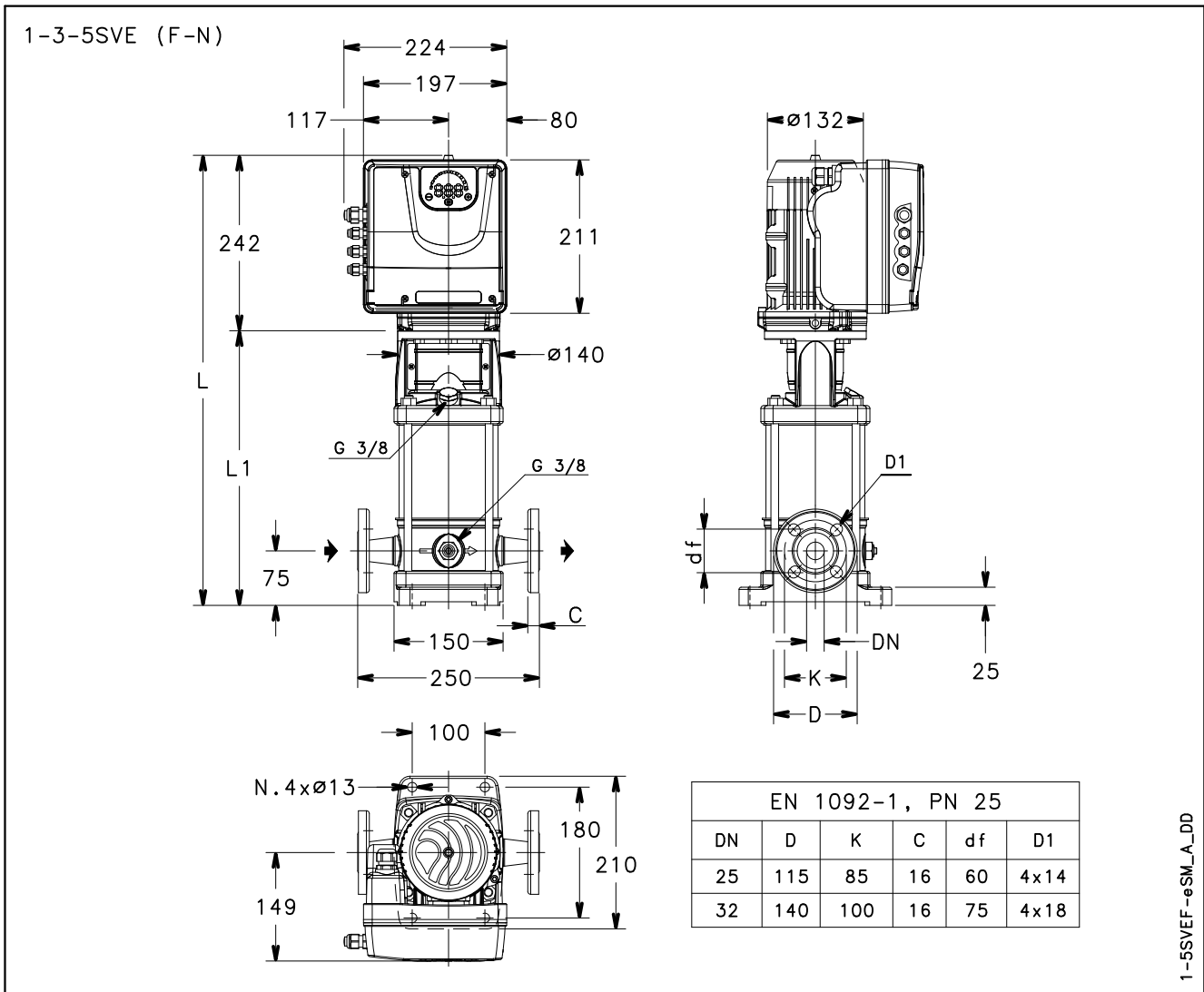

PUMP TYPE SVE F (SINGLE-PHASE)	MOTOR		DIMENSIONS (mm)			WEIGHT (kg)	
	kW	SIZE	L	L1	DN	PUMP	ELECTRIC PUMP
1SVE05F003P0M	0,37	90	580	338	25	10,1	17,6
1SVE08F005P0M	0,55	90	640	398	25	11,2	18,7
1SVE11F007P0M	0,75	90	700	458	25	12,4	19,9
1SVE15F011P0M	1,1	90	780	538	25	14,2	23,2
1SVE20F015P0M	1,5	90	880	638	25	16,2	25,2
3SVE03F003P0M	0,37	90	540	298	25	9,1	16,6
3SVE05F005P0M	0,55	90	580	338	25	9,9	17,4
3SVE07F007P0M	0,75	90	620	378	25	11,2	18,7
3SVE09F011P0M	1,1	90	660	418	25	12	21
3SVE11F015P0M	1,5	90	700	458	25	12,8	21,8
5SVE02F003P0M	0,37	90	530	288	32	9,1	16,6
5SVE03F005P0M	0,55	90	555	313	32	9,6	17,1
5SVE04F007P0M	0,75	90	580	338	32	10,1	17,6
5SVE06F011P0M	1,1	90	630	388	32	11,3	20,3
5SVE08F015P0M	1,5	90	680	438	32	12,4	21,4

1-5svef-esm-2p50-en_a_dd

1, 3, 5SVE..F SERIES - THREE PHASE VERSION DIMENSIONS AND WEIGHTS

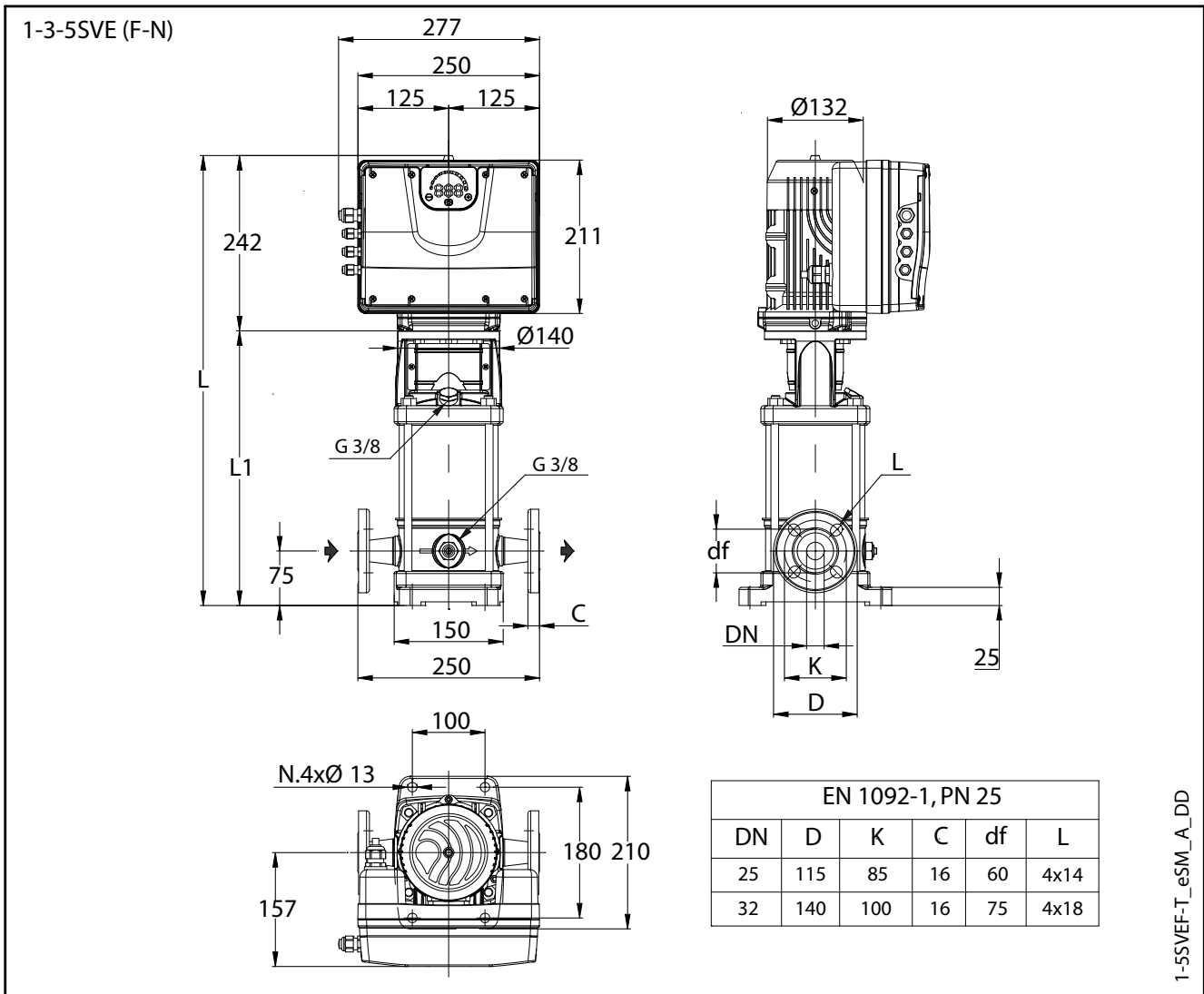

PUMP TYPE SVE F (THREE-PHASE)	MOTOR		DIMENSIONS (mm)			WEIGHT (kg)	
	kW	SIZE	L	L1	DN	PUMP	ELECTRIC
1SVE05F003POT	0,37	90	580	338	25	10,1	23,2
1SVE08F005POT	0,55	90	640	398	25	11,2	24,3
1SVE11F007POT	0,75	90	700	458	25	12,4	25,5
1SVE15F011POT	1,1	90	780	538	25	14,2	28,7
1SVE20F015POT	1,5	90	880	638	25	16,2	30,7
1SVE26F022POT	2,2	90	1000	758	25	18,6	34,6
3SVE03F003POT	0,37	90	540	298	25	9,1	22,2
3SVE05F005POT	0,55	90	580	338	25	9,9	23
3SVE07F007POT	0,75	90	620	378	25	11,2	24,3
3SVE09F011POT	1,1	90	660	418	25	12	26,5
3SVE11F015POT	1,5	90	700	458	25	12,8	27,3
3SVE17F022POT	2,2	90	820	578	25	15,2	31,2
5SVE02F003POT	0,37	90	530	288	32	9,1	22,2
5SVE03F005POT	0,55	90	555	313	32	9,6	22,7
5SVE04F007POT	0,75	90	580	338	32	10,1	23,2
5SVE06F011POT	1,1	90	630	388	32	11,3	25,8
5SVE08F015POT	1,5	90	680	438	32	12,4	26,9
5SVE12F022POT	2,2	90	780	538	32	12,4	28,4

1, 3, 5SVE..T SERIES - SINGLE PHASE VERSION DIMENSIONS AND WEIGHTS

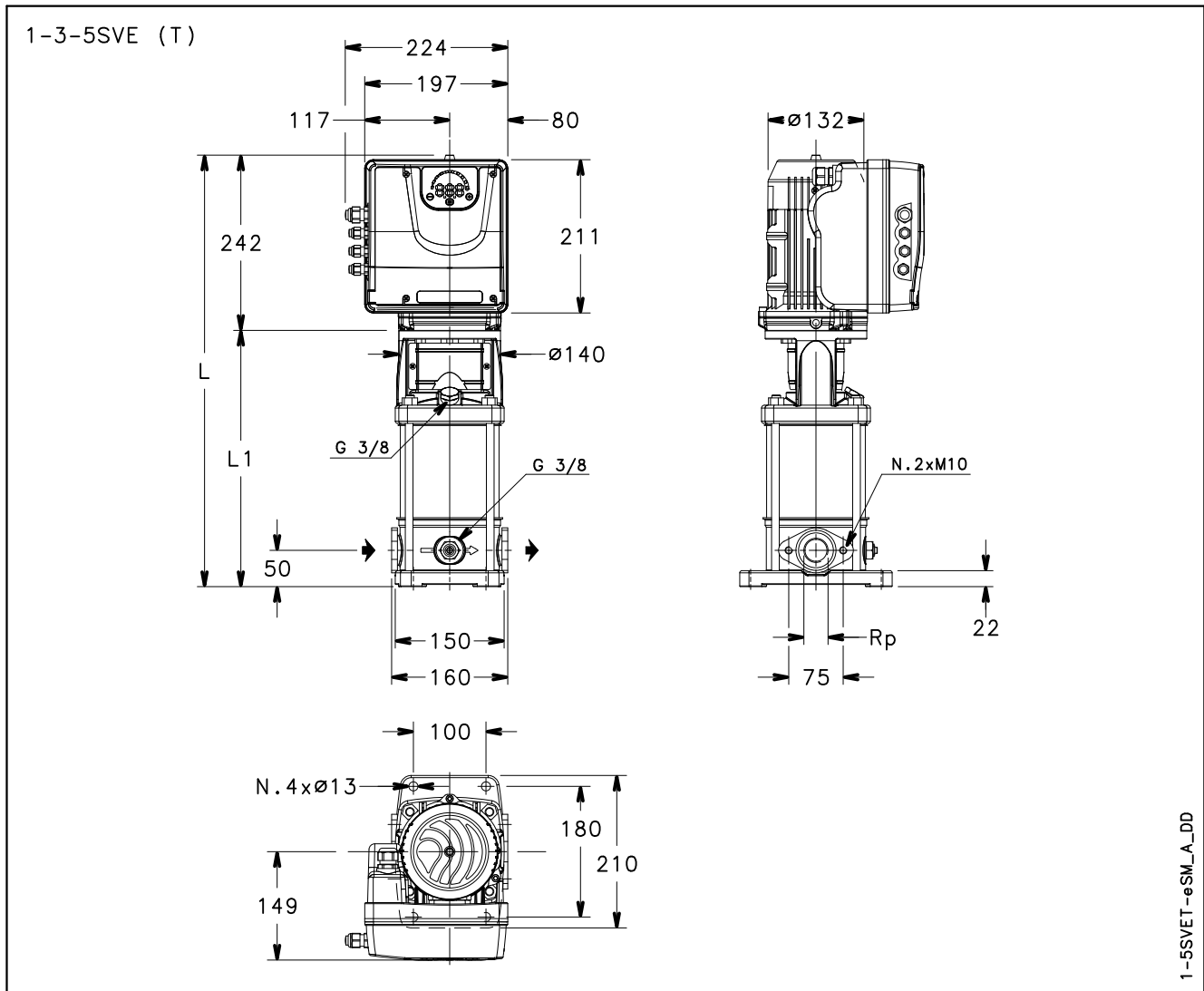

PUMP TYPE SVE T (SINGLE-PHASE)	MOTOR		DIMENSIONS (mm)			WEIGHT (kg)	
	kW	SIZE	L	L1	Rp	PUMP	ELECTRIC PUMP
1SVE05T003P0M	0,37	90	555	313	1	9,6	17,1
1SVE08T005P0M	0,55	90	615	373	1	10,7	18,2
1SVE11T007P0M	0,75	90	675	433	1	11,9	19,4
1SVE15T011P0M	1,1	90	755	513	1	13,7	22,7
3SVE03T003P0M	0,37	90	515	273	1	8,6	16,1
3SVE05T005P0M	0,55	90	555	313	1	9,4	16,9
3SVE07T007P0M	0,75	90	595	353	1	10,7	18,2
3SVE09T011P0M	1,1	90	635	393	1	11,5	20,5
3SVE11T015P0M	1,5	90	675	433	1	12,3	21,3
5SVE02T003P0M	0,37	90	505	263	1 1/4	8,2	15,7
5SVE03T005P0M	0,55	90	530	288	1 1/4	8,7	16,2
5SVE04T007P0M	0,75	90	555	313	1 1/4	9,2	16,7
5SVE06T011P0M	1,1	90	605	363	1 1/4	10,4	19,4
5SVE08T015P0M	1,5	90	655	413	1 1/4	11,5	20,5

1-5sveT-esm-2p50-en_a_dd

1, 3, 5SVE..T SERIES - THREE PHASE VERSION DIMENSIONS AND WEIGHTS

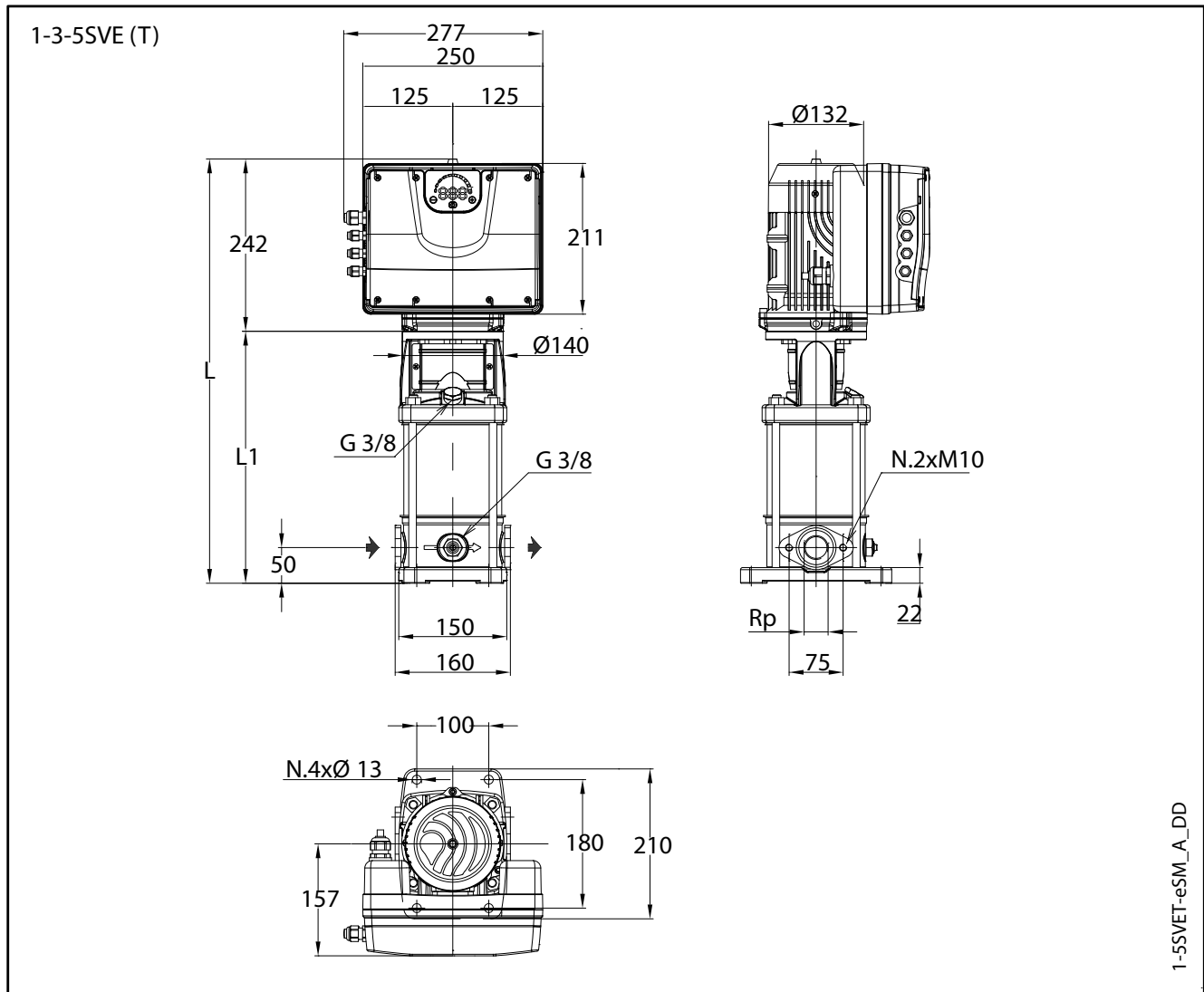

1-5SVE-T-esm_A_DD

PUMP TYPE SVE T (THREE-PHASE)	MOTOR		DIMENSIONS (mm)			WEIGHT (kg)	
	kw	SIZE	L	L1	Rp	PUMP	ELECTRIC PUMP
1SVE05T003POT	0,37	90	555	313	1	9,6	22,7
1SVE08T005POT	0,55	90	615	373	1	10,7	23,8
1SVE11T007POT	0,75	90	675	433	1	11,9	25
1SVE15T011POT	1,1	90	755	513	1	14,1	28,6
3SVE03T003POT	0,37	90	515	273	1	8,6	21,7
3SVE05T005POT	0,55	90	555	313	1	9,4	22,5
3SVE07T007POT	0,75	90	595	353	1	10,7	23,8
3SVE09T011POT	1,1	90	635	393	1	11,5	26
3SVE11T015POT	1,5	90	675	433	1	12,3	26,8
5SVE02T003POT	0,37	90	505	263	1 1/4	8,2	21,3
5SVE03T005POT	0,55	90	530	288	1 1/4	8,7	21,8
5SVE04T007POT	0,75	90	555	313	1 1/4	9,2	22,3
5SVE06T011POT	1,1	90	605	363	1 1/4	10,4	24,9
5SVE08T015POT	1,5	90	655	413	1 1/4	11,5	26
5SVE12T022POT	2,2	90	755	513	1 1/4	13,7	29,7

1-5sveT-esm-2p50T-en_a_td

1, 3, 5SVE..R SERIES - SINGLE PHASE VERSION DIMENSIONS AND WEIGHTS

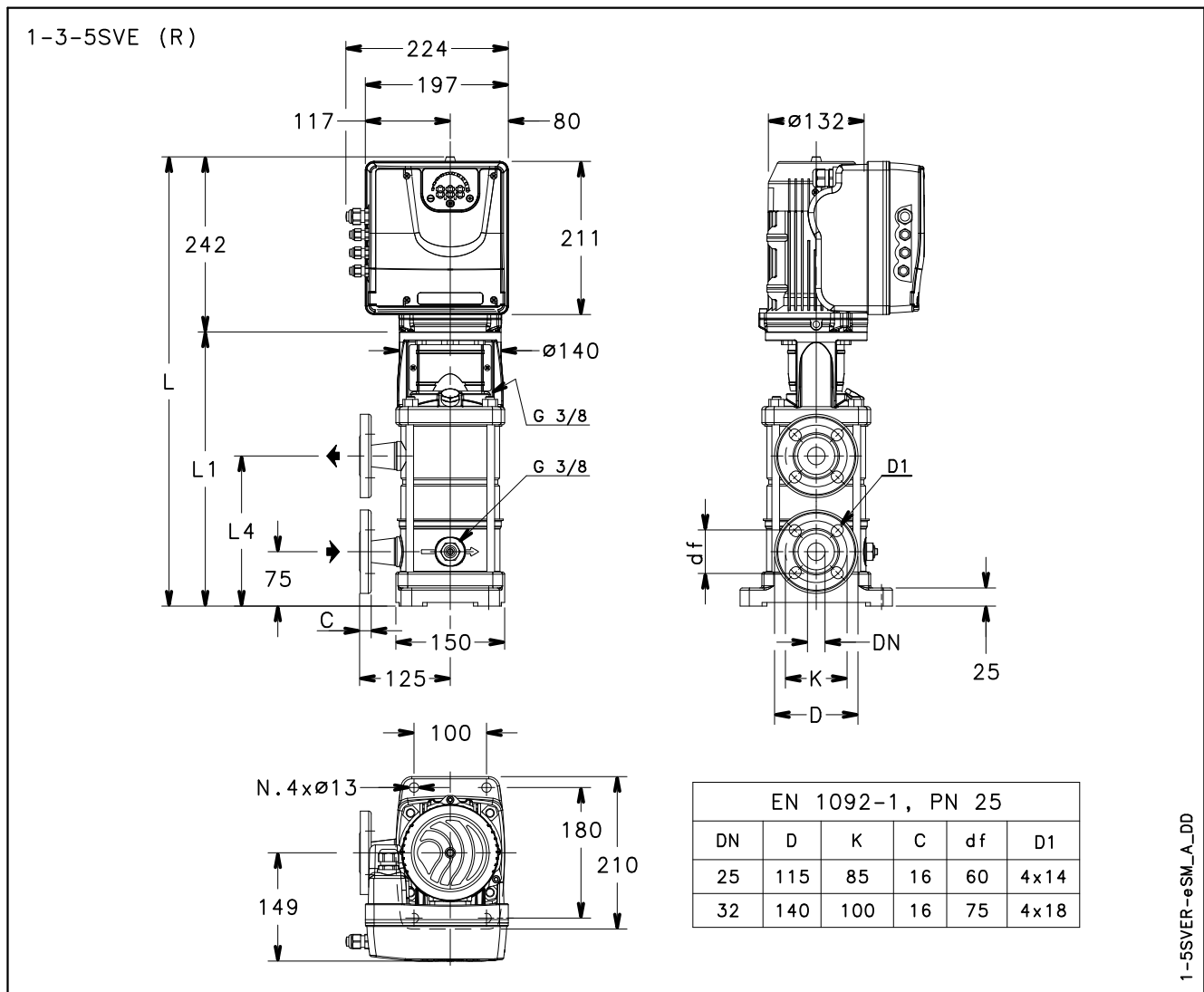

PUMP TYPE SVE R (SINGLE-PHASE)	MOTOR		DIMENSIONS (mm)				WEIGHT (kg)	
	kW	SIZE	L	L1	L4	DN	PUMP	ELECTRIC PUMP
1SVE08R005P0M	0,55	90	640	398	227	25	11,6	19,1
1SVE11R007P0M	0,75	90	700	458	287	25	12,8	20,3
1SVE15R011P0M	1,1	90	780	538	367	25	14,6	23,6
1SVE20R015P0M	1,5	90	880	638	467	25	16,6	25,7
3SVE07R007P0M	0,75	90	620	378	207	25	11,6	19,1
3SVE09R011P0M	1,1	90	660	418	247	25	12,4	21,4
3SVE11R015P0M	1,5	90	700	458	287	25	13,2	22,2
5SVE08R015P0M	1,5	90	680	438	267	32	13	22

1-5sveR-esm-2p50-en_a_td

1, 3, 5SVE..R SERIES - THREE PHASE VERSION DIMENSIONS AND WEIGHTS

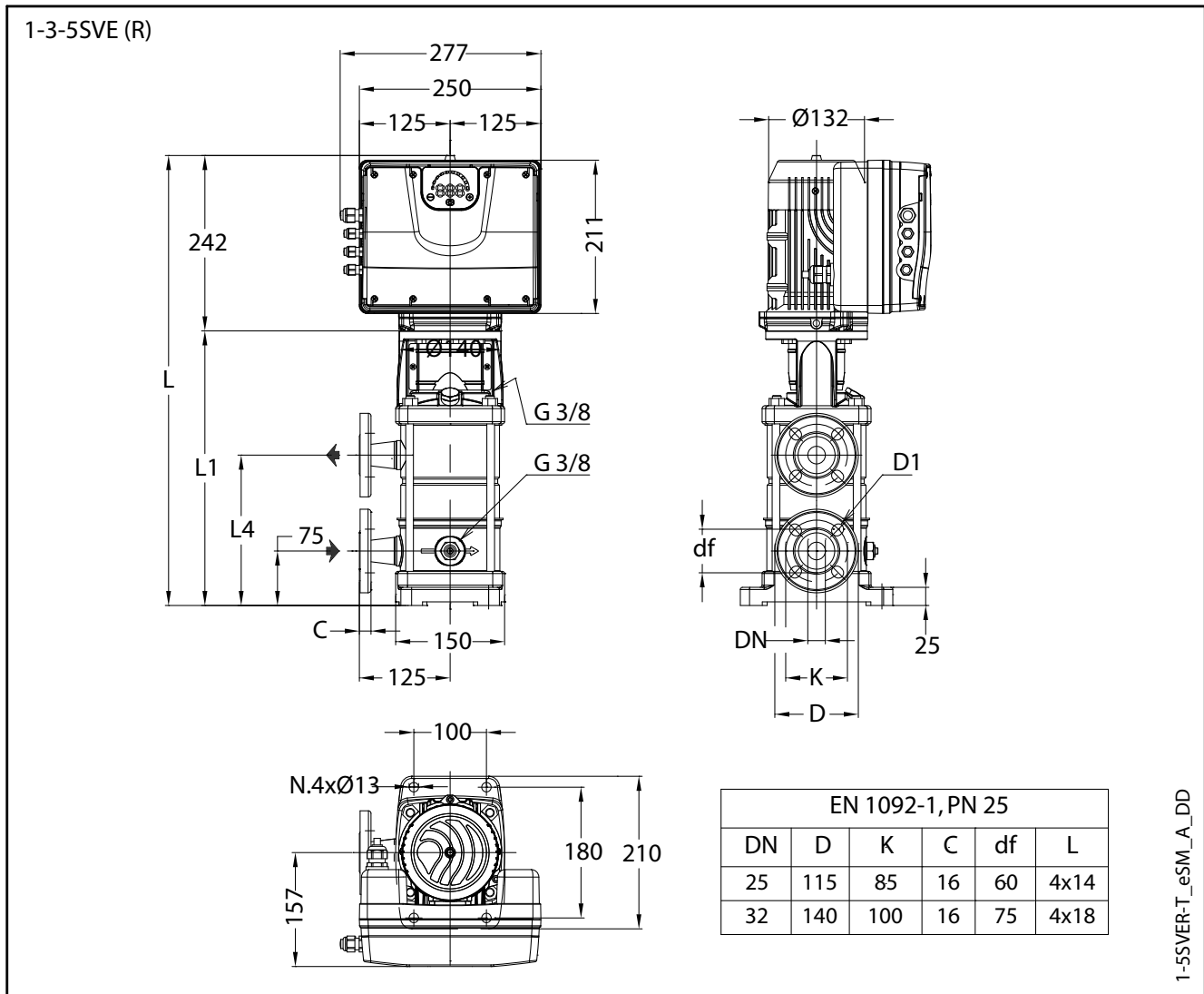

PUMP TYPE SVE R (THREE-PHASE)	MOTOR		DIMENSIONS (mm)				WEIGHT (kg)	
	kW	SIZE	L	L1	L4	DN	PUMP	ELECTRIC PUMP
1SVE08R005POT	0,55	90	640	398	227	25	11,6	24,7
1SVE11R007POT	0,75	90	700	458	287	25	12,8	25,9
1SVE15R011POT	1,1	90	780	538	367	25	14,6	29,1
1SVE20R015POT	1,5	90	880	638	467	25	16,6	31,1
1SVE26R022POT	2,20	90	1000	758	467	25	20,2	36,2
3SVE07R007POT	0,75	90	620	378	207	25	11,6	24,7
3SVE09R011POT	1,1	90	660	418	247	25	12,4	26,9
3SVE11R015POT	1,5	90	700	458	287	25	13,2	27,7
3SVE17R022POT	2,2	90	820	578	287	25	15,6	31,6
5SVE08R015POT	1,5	90	680	438	267	32	13	27,5
5SVE12R022POT	2,2	90	780	538	267	32	17,4	33,4

1SVE SERIES OPERATING CHARACTERISTICS

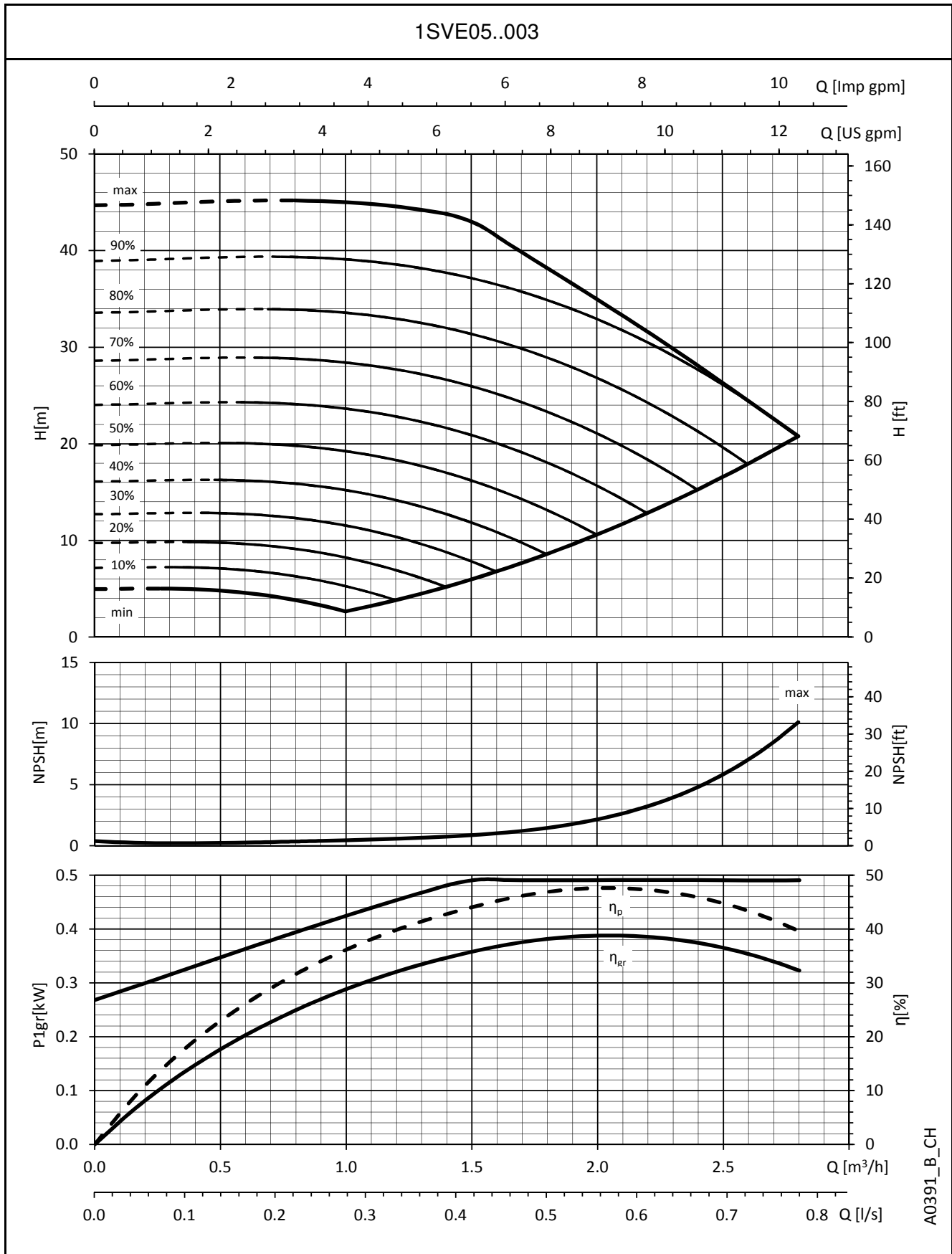

A0391_B_CH

The performances are valid for liquid with density $\rho = 1.0 \text{ Kg/dm}^3$ and kinematic viscosity $\nu = 1 \text{ mm}^2/\text{sec}$.

1SVE SERIES OPERATING CHARACTERISTICS

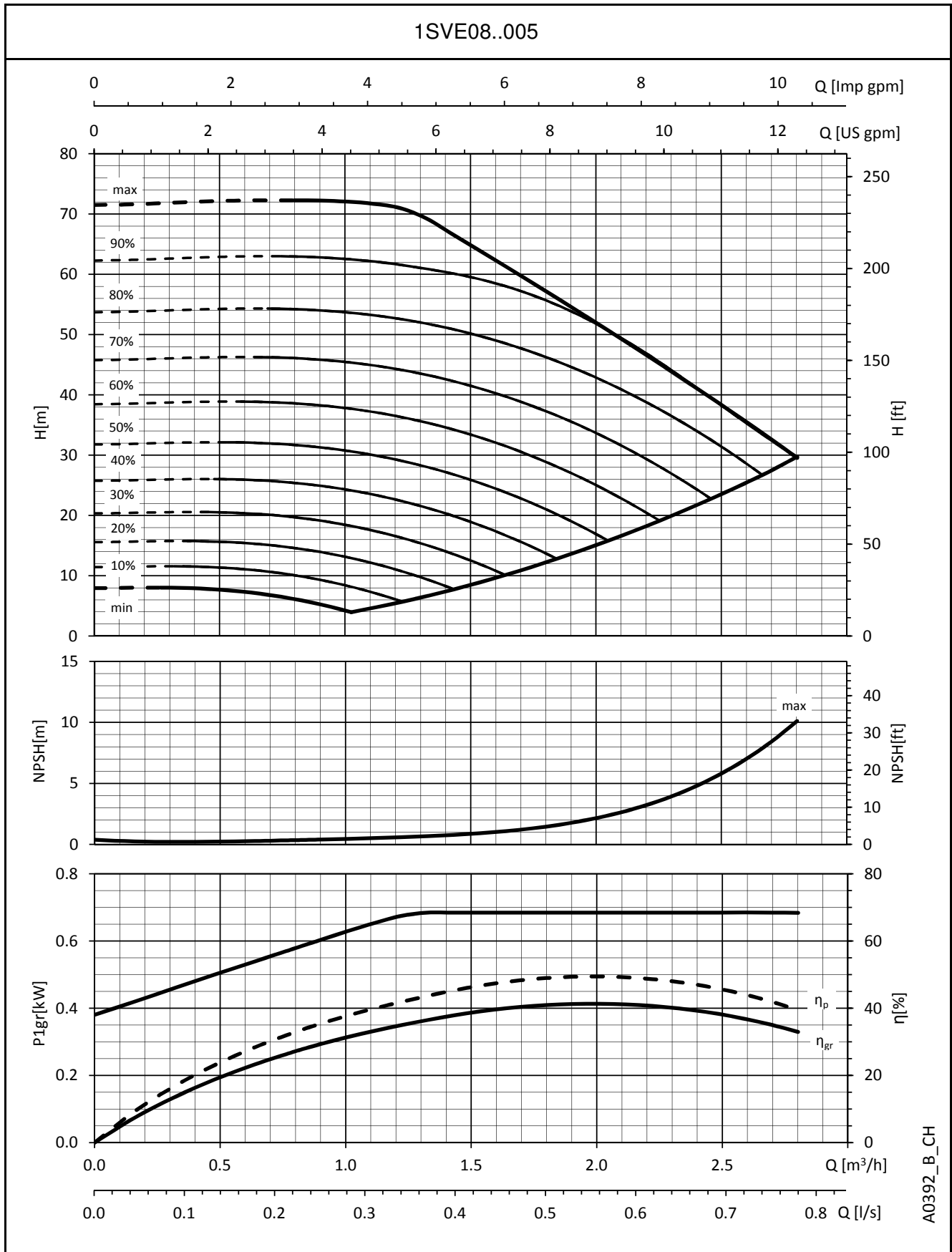

A0392_B_CH

The performances are valid for liquid with density $\rho = 1.0 \text{ Kg/dm}^3$ and kinematic viscosity $\nu = 1 \text{ mm}^2/\text{sec}$.

1SVE SERIES OPERATING CHARACTERISTICS

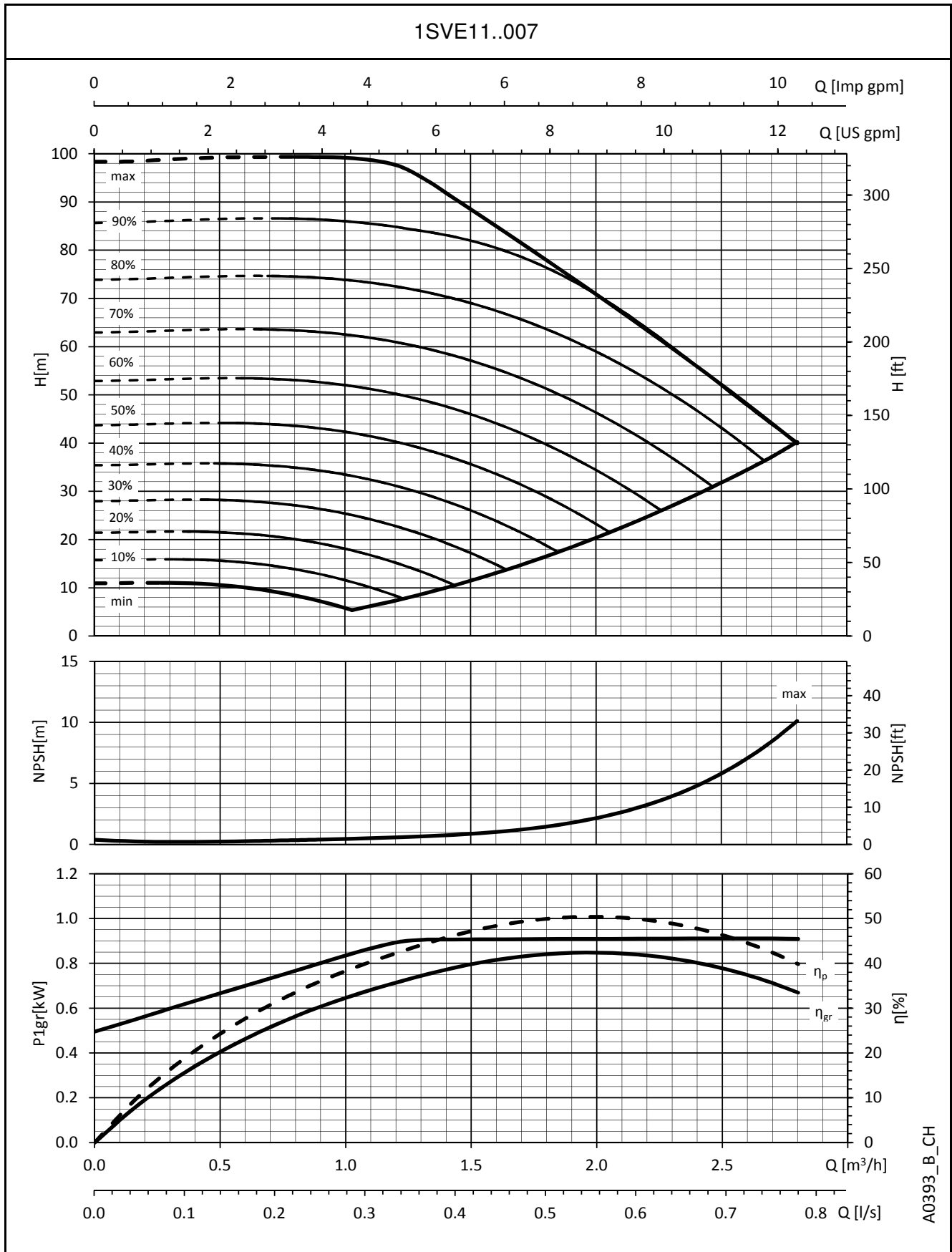

A0393_B_CH

The performances are valid for liquid with density $\rho = 1.0 \text{ Kg/dm}^3$ and kinematic viscosity $\nu = 1 \text{ mm}^2/\text{sec}$.

1SVE SERIES OPERATING CHARACTERISTICS

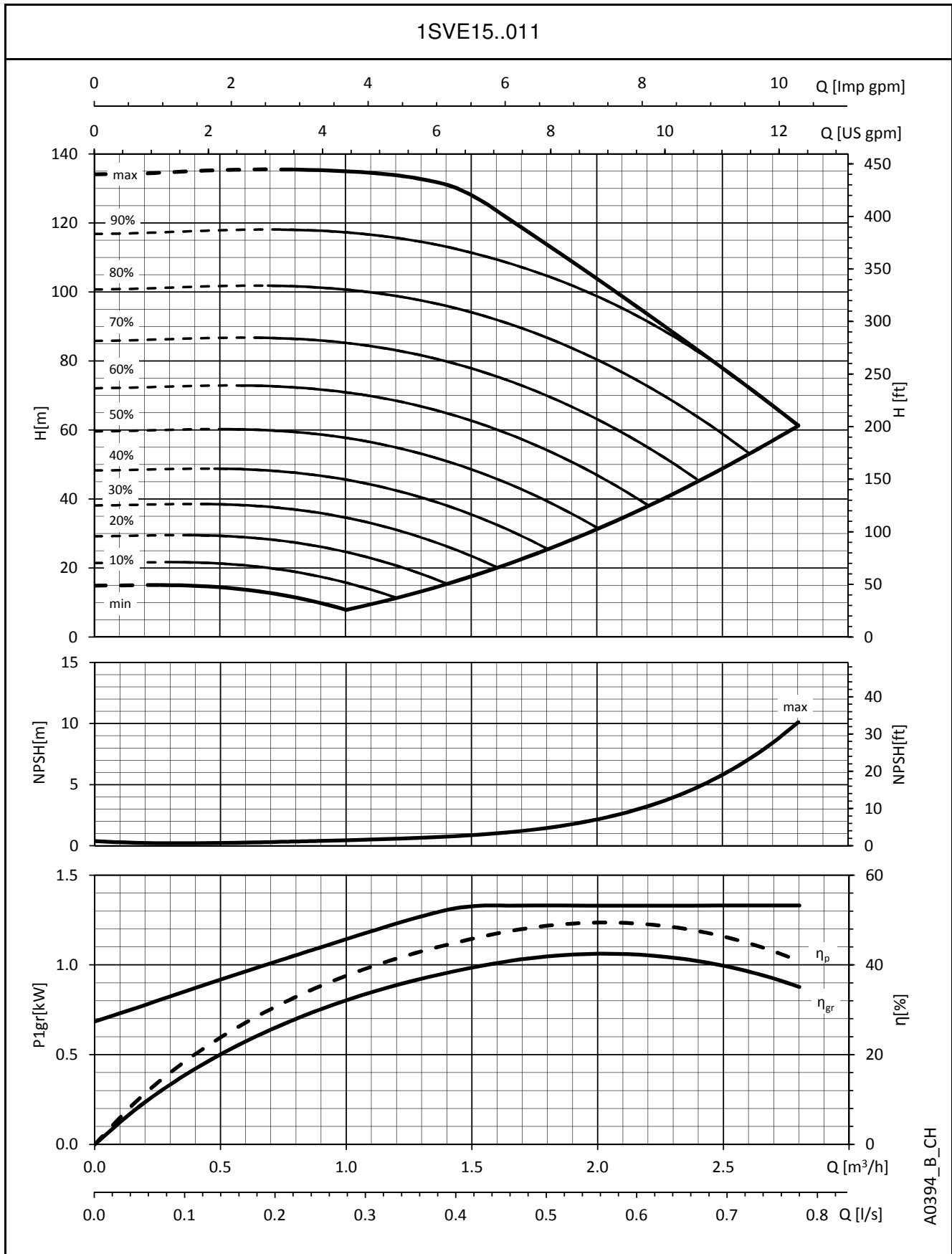

A0394_B_CH

The performances are valid for liquid with density $\rho = 1.0 \text{ Kg/dm}^3$ and kinematic viscosity $\nu = 1 \text{ mm}^2/\text{sec}$.

1SVE SERIES OPERATING CHARACTERISTICS

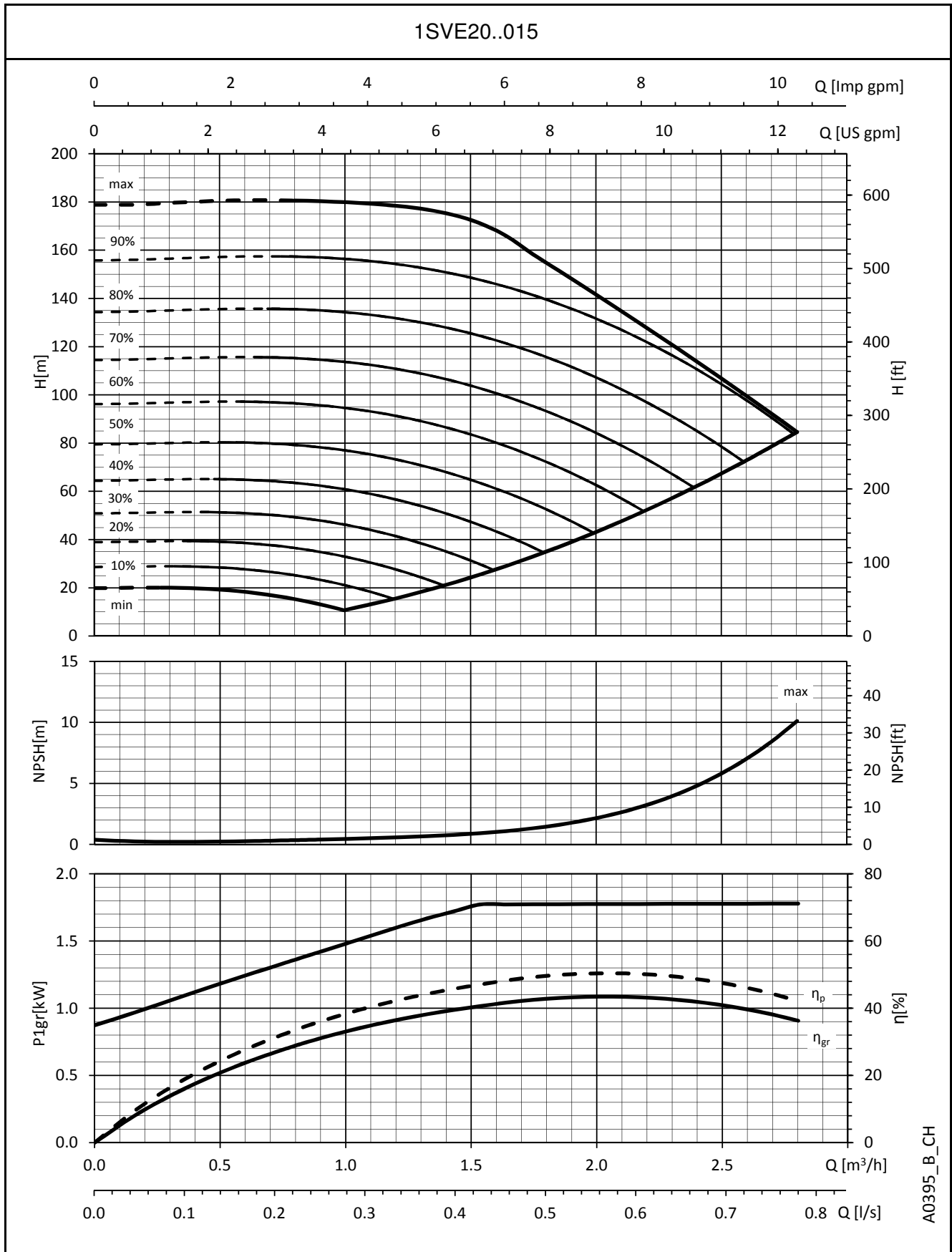

A0395_B_CH

The performances are valid for liquid with density $\rho = 1.0 \text{ Kg/dm}^3$ and kinematic viscosity $\nu = 1 \text{ mm}^2/\text{sec}$.

1SVE SERIES OPERATING CHARACTERISTICS

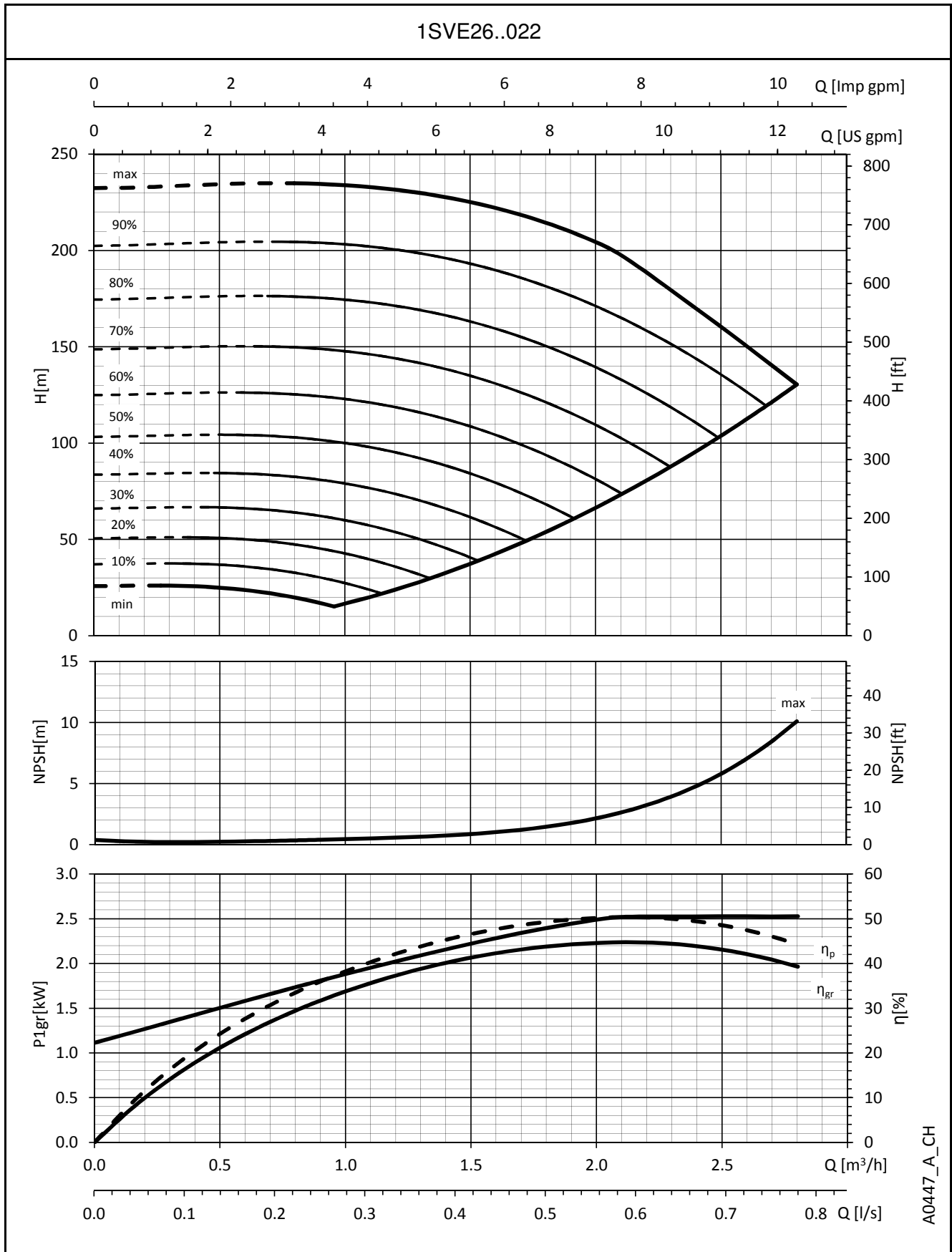

A0447_A_CH

The performances are valid for liquid with density $\rho = 1.0 \text{ Kg/dm}^3$ and kinematic viscosity $\nu = 1 \text{ mm}^2/\text{sec}$.

3SVE SERIES OPERATING CHARACTERISTICS

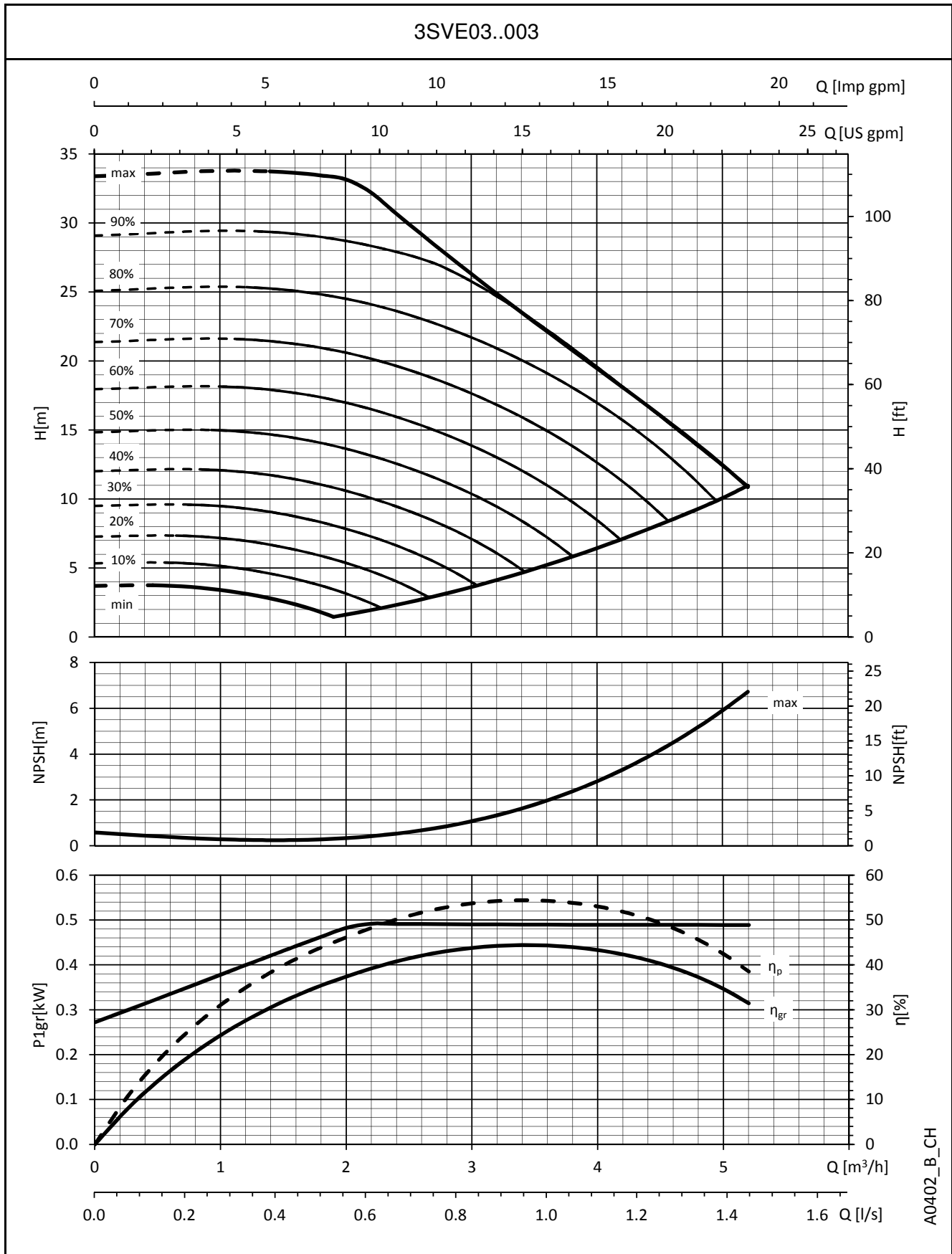

A0402_B_CH

The performances are valid for liquid with density $\rho = 1.0 \text{ Kg/dm}^3$ and kinematic viscosity $\nu = 1 \text{ mm}^2/\text{sec}$.

3SVE SERIES OPERATING CHARACTERISTICS

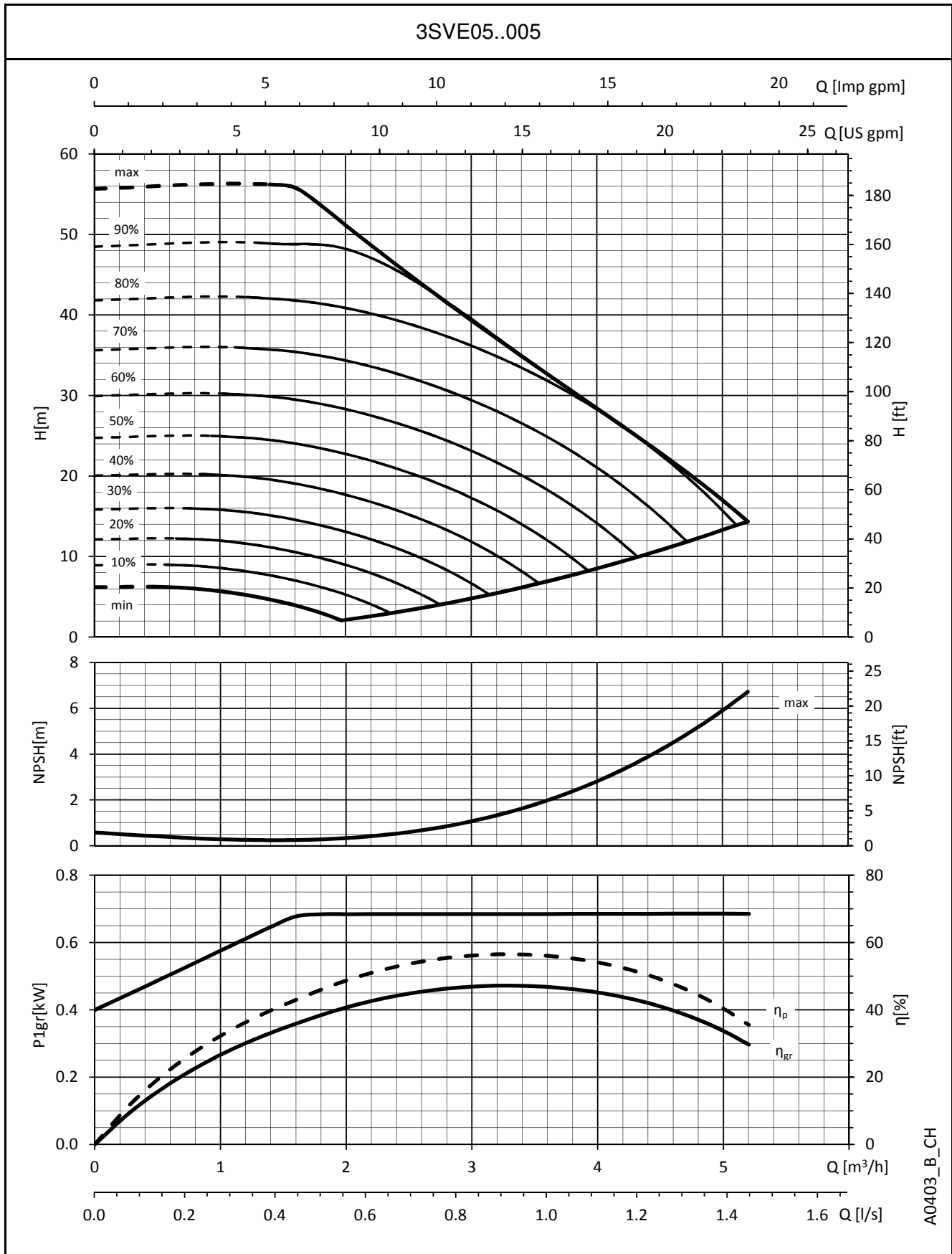

A0403_B_CH

The performances are valid for liquid with density $\rho = 1.0 \text{ Kg/dm}^3$ and kinematic viscosity $\nu = 1 \text{ mm}^2/\text{sec}$.

3SVE SERIES OPERATING CHARACTERISTICS

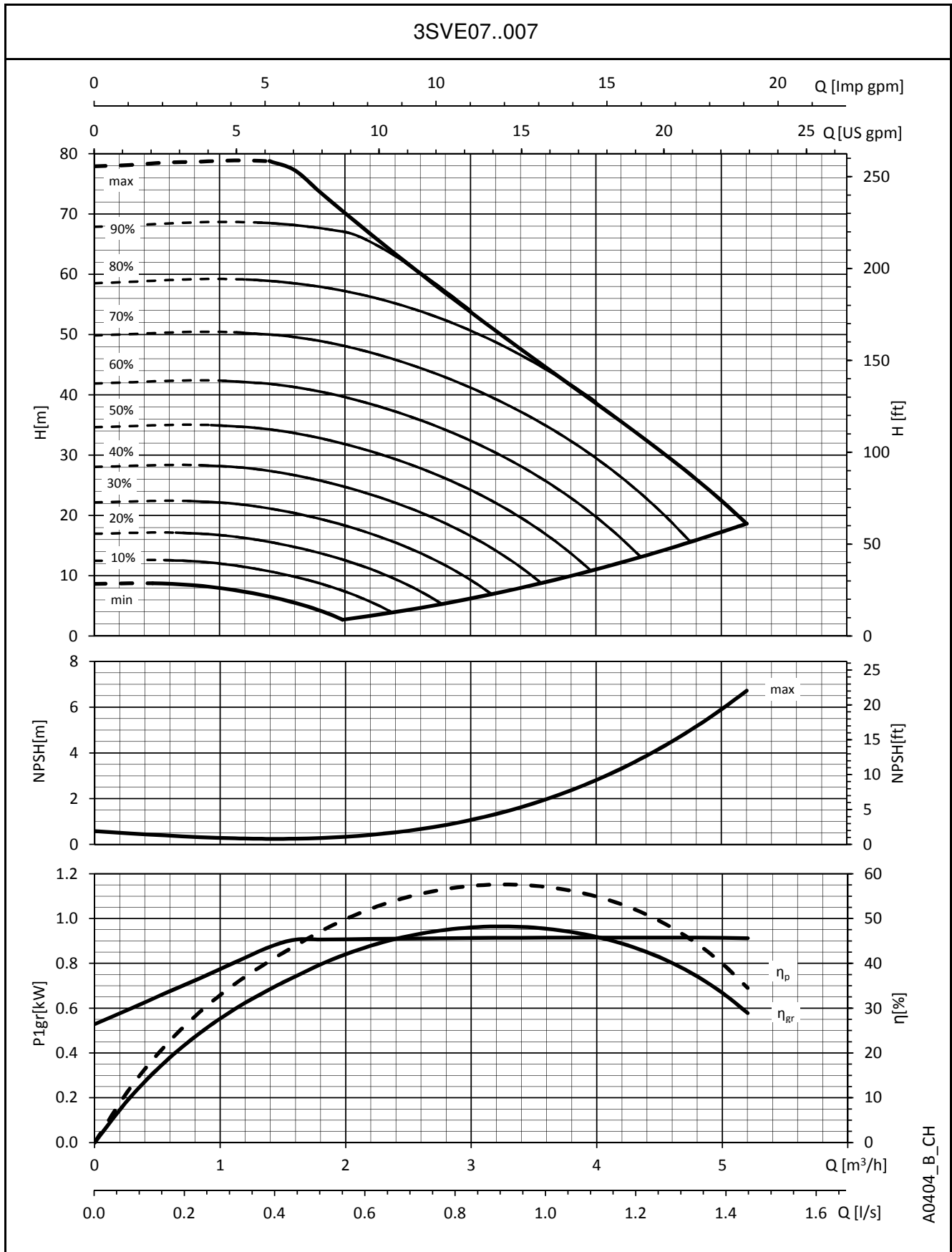

A0404_B_CH

The performances are valid for liquid with density $\rho = 1.0 \text{ Kg/dm}^3$ and kinematic viscosity $\nu = 1 \text{ mm}^2/\text{sec}$.

3SVE SERIES OPERATING CHARACTERISTICS

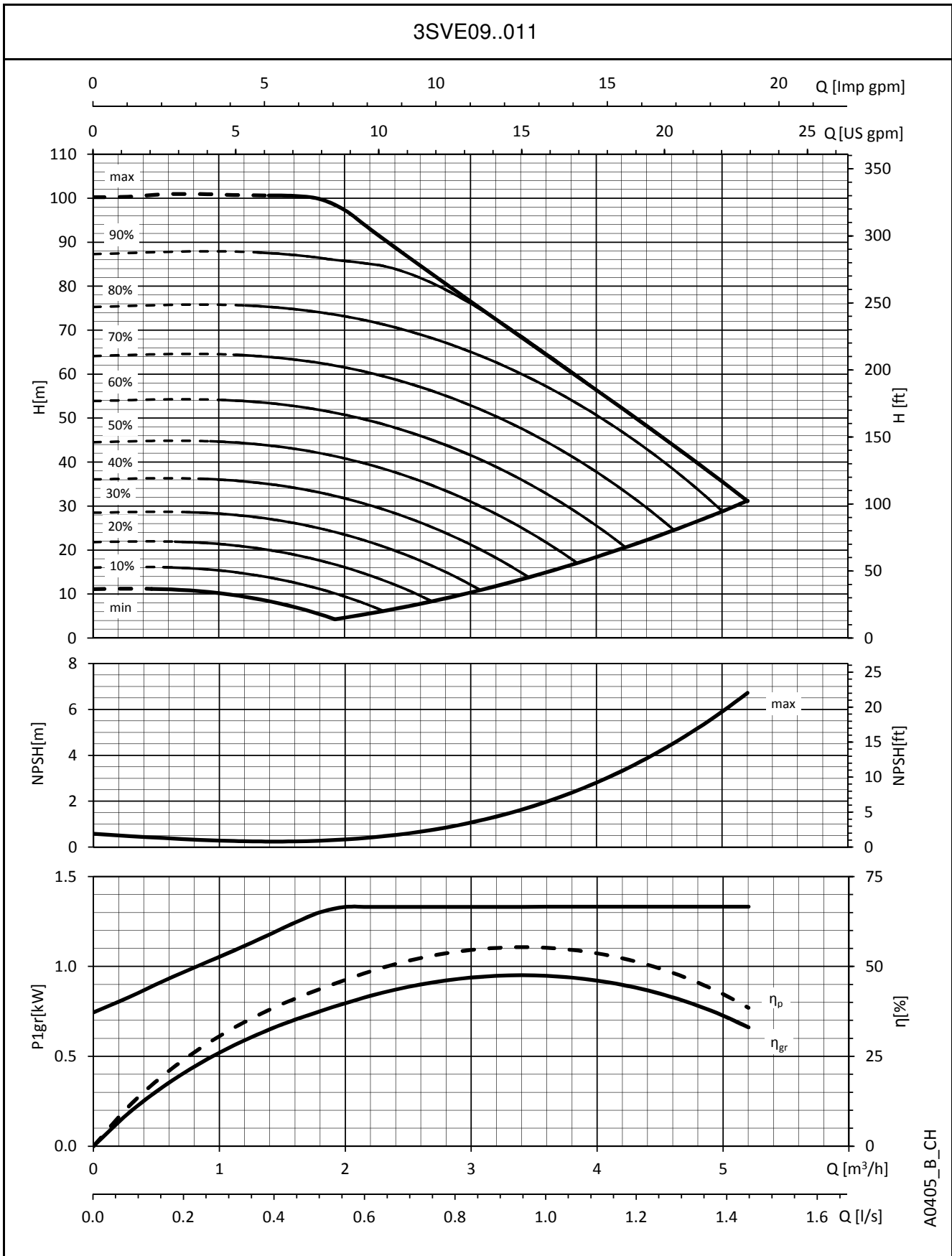

A0405_B_CH

The performances are valid for liquid with density $\rho = 1.0 \text{ Kg/dm}^3$ and kinematic viscosity $\nu = 1 \text{ mm}^2/\text{sec}$.

3SVE SERIES OPERATING CHARACTERISTICS

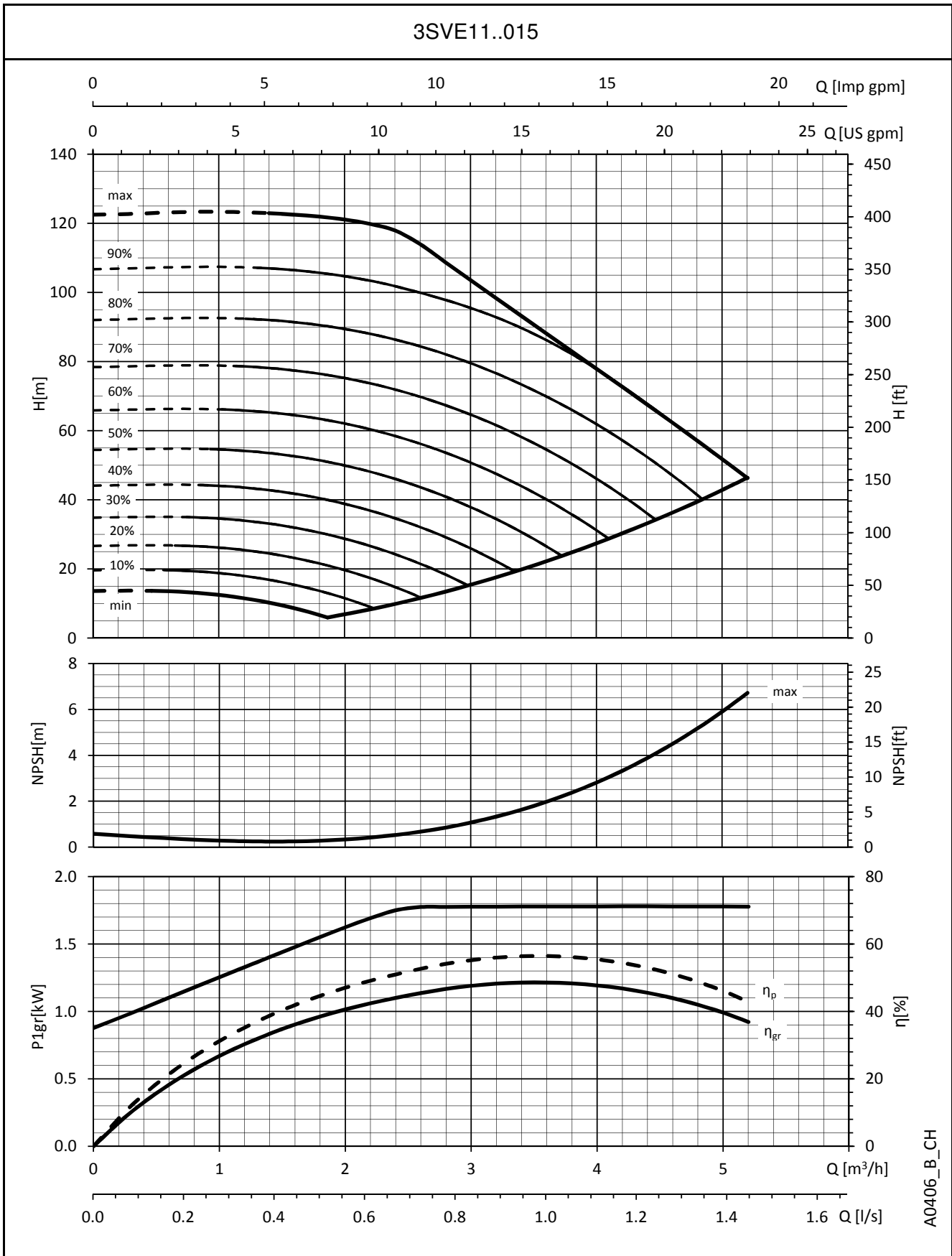

A0406_B_CH

The performances are valid for liquid with density $\rho = 1.0 \text{ Kg/dm}^3$ and kinematic viscosity $\nu = 1 \text{ mm}^2/\text{sec}$.

3SVE SERIES OPERATING CHARACTERISTICS

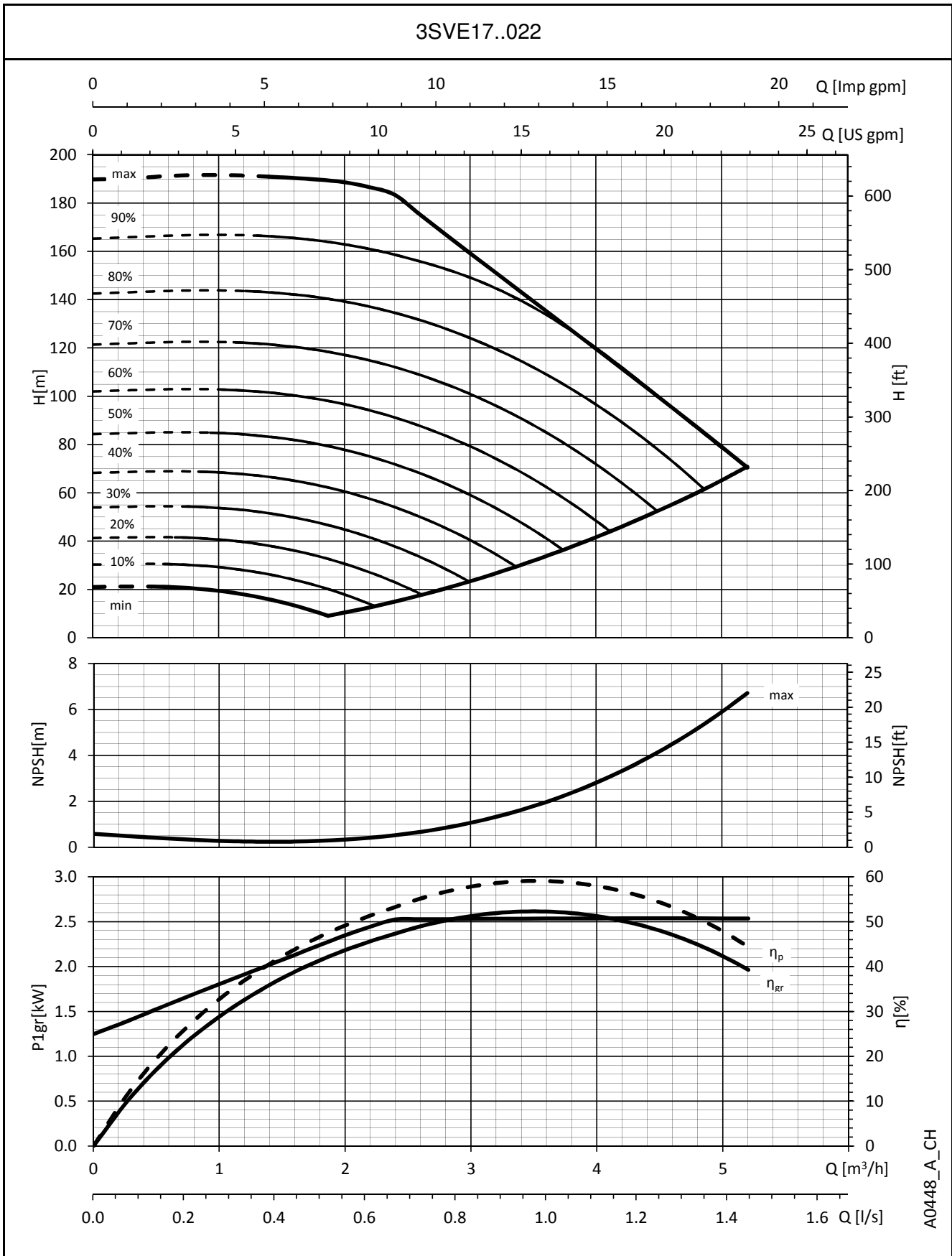

A0448_A_CH

The performances are valid for liquid with density $\rho = 1.0 \text{ Kg/dm}^3$ and kinematic viscosity $\nu = 1 \text{ mm}^2/\text{sec}$.

**5SVE SERIES
OPERATING CHARACTERISTICS**

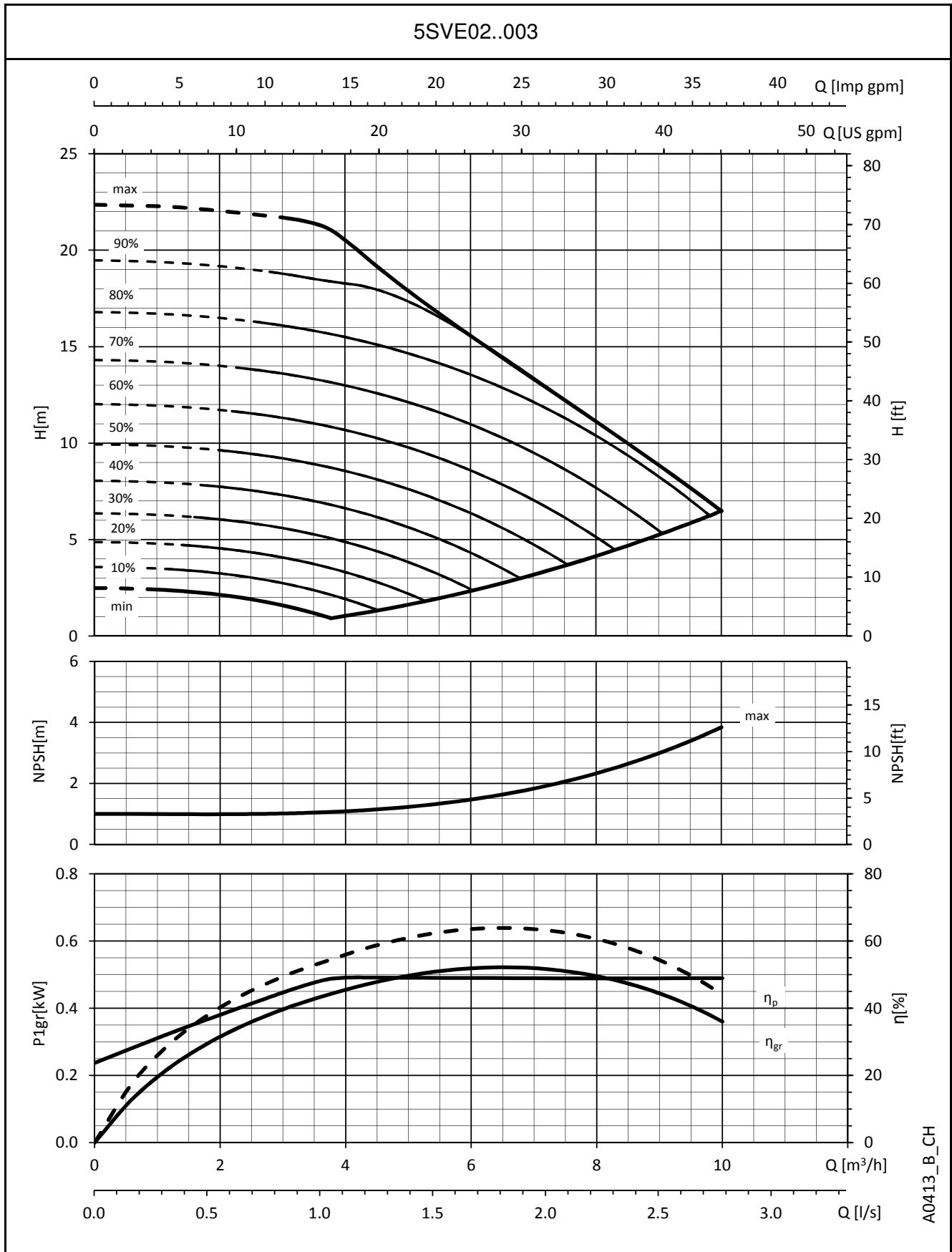

The performances are valid for liquid with density $\rho = 1.0 \text{ Kg/dm}^3$ and kinematic viscosity $\nu = 1 \text{ mm}^2/\text{sec}$.

**5SVE SERIES
OPERATING CHARACTERISTICS**

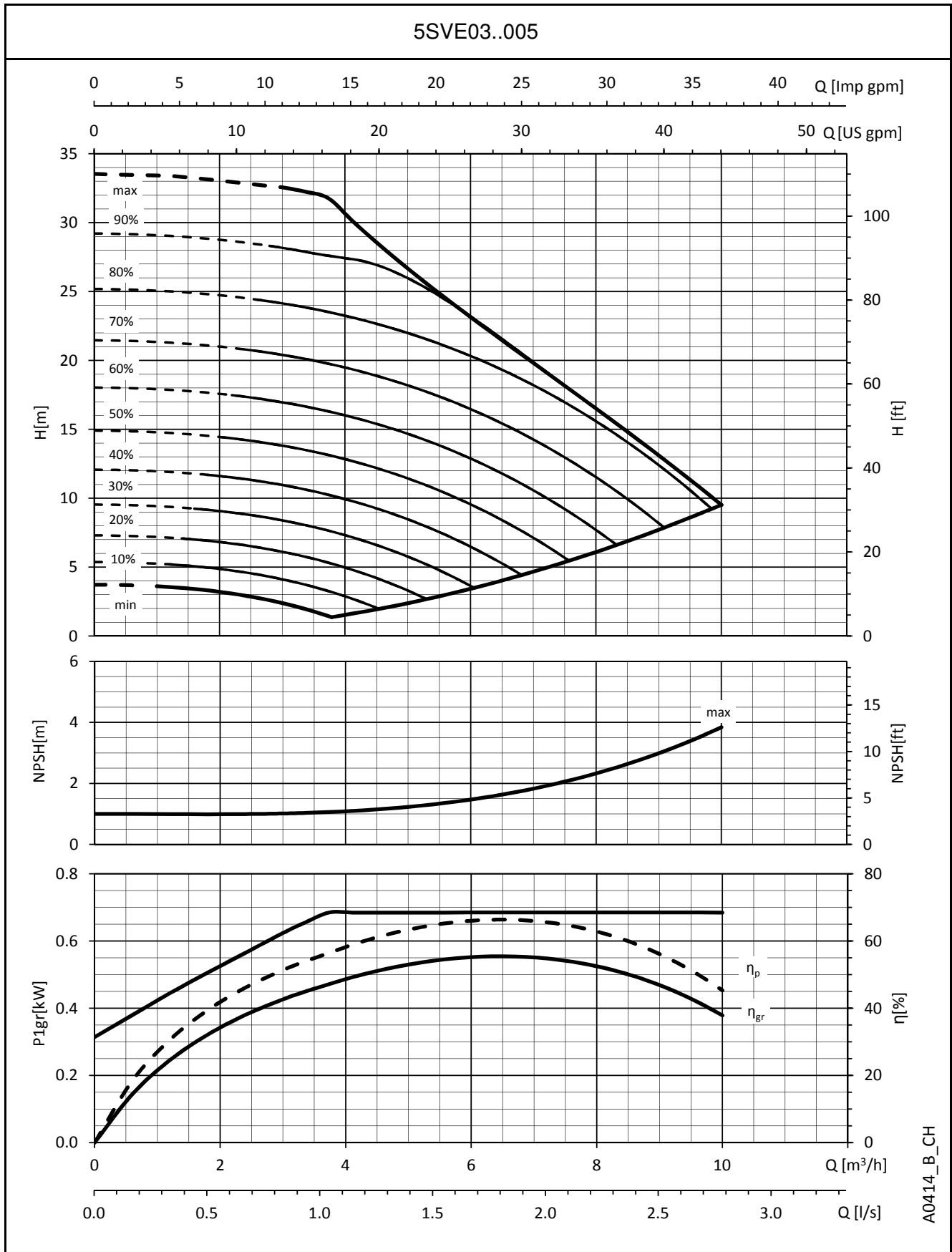

A0414_B_CH

The performances are valid for liquid with density $\rho = 1.0 \text{ Kg/dm}^3$ and kinematic viscosity $\nu = 1 \text{ mm}^2/\text{sec}$.

**5SVE SERIES
OPERATING CHARACTERISTICS**

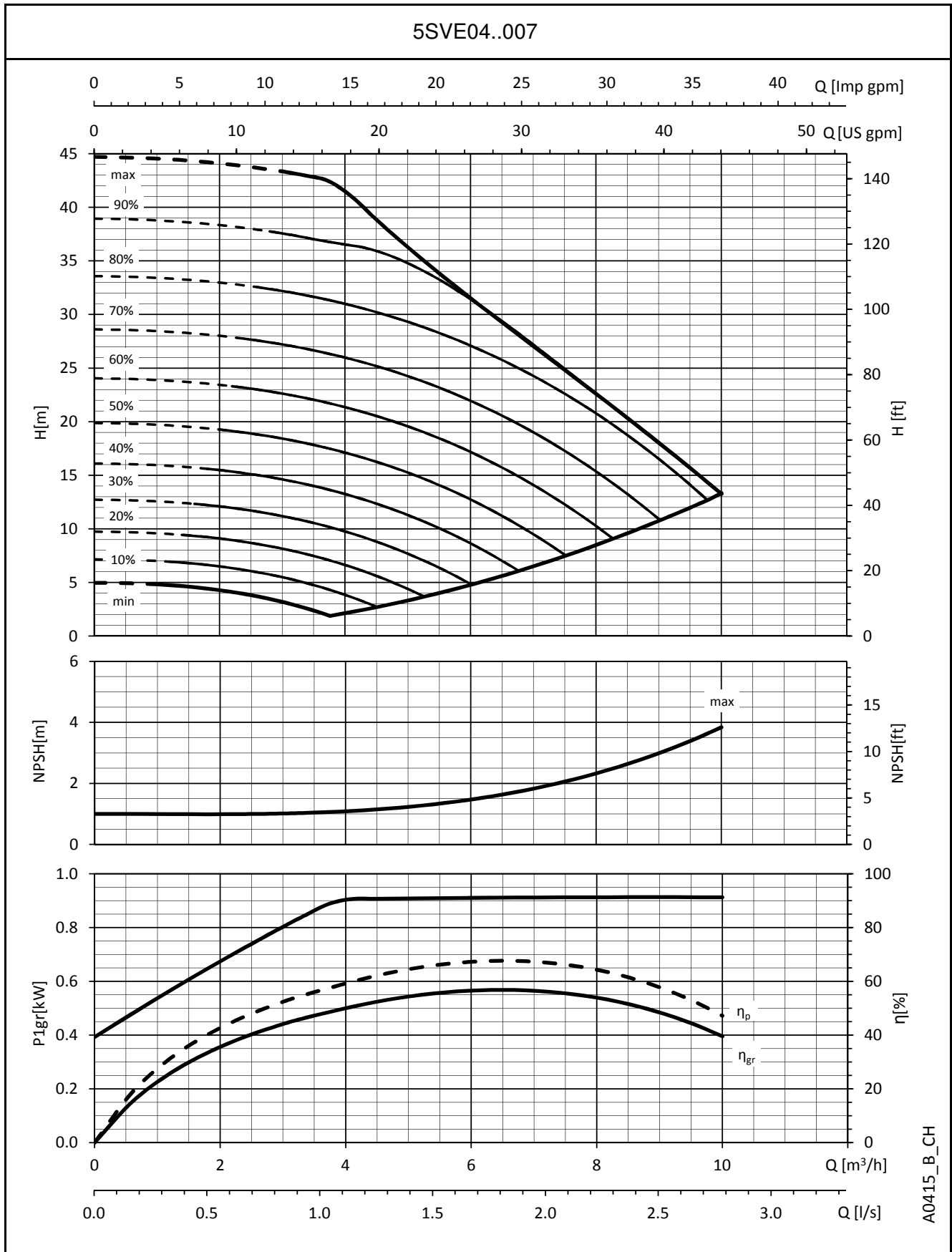

A0415_B_CH

The performances are valid for liquid with density $\rho = 1.0 \text{ Kg/dm}^3$ and kinematic viscosity $\nu = 1 \text{ mm}^2/\text{sec}$.

**5SVE SERIES
OPERATING CHARACTERISTICS**

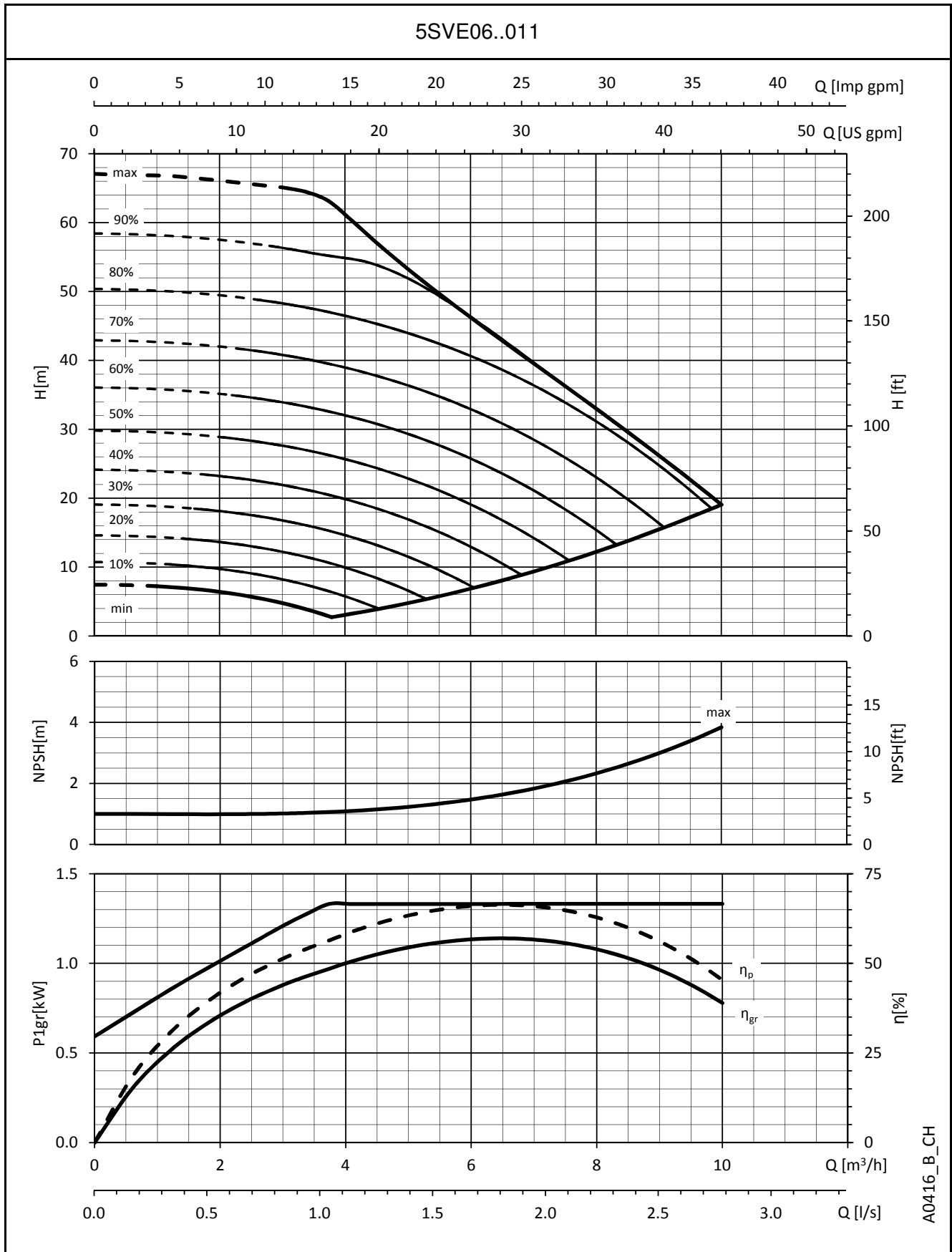

The performances are valid for liquid with density $\rho = 1.0 \text{ Kg/dm}^3$ and kinematic viscosity $\nu = 1 \text{ mm}^2/\text{sec}$.

**5SVE SERIES
OPERATING CHARACTERISTICS**

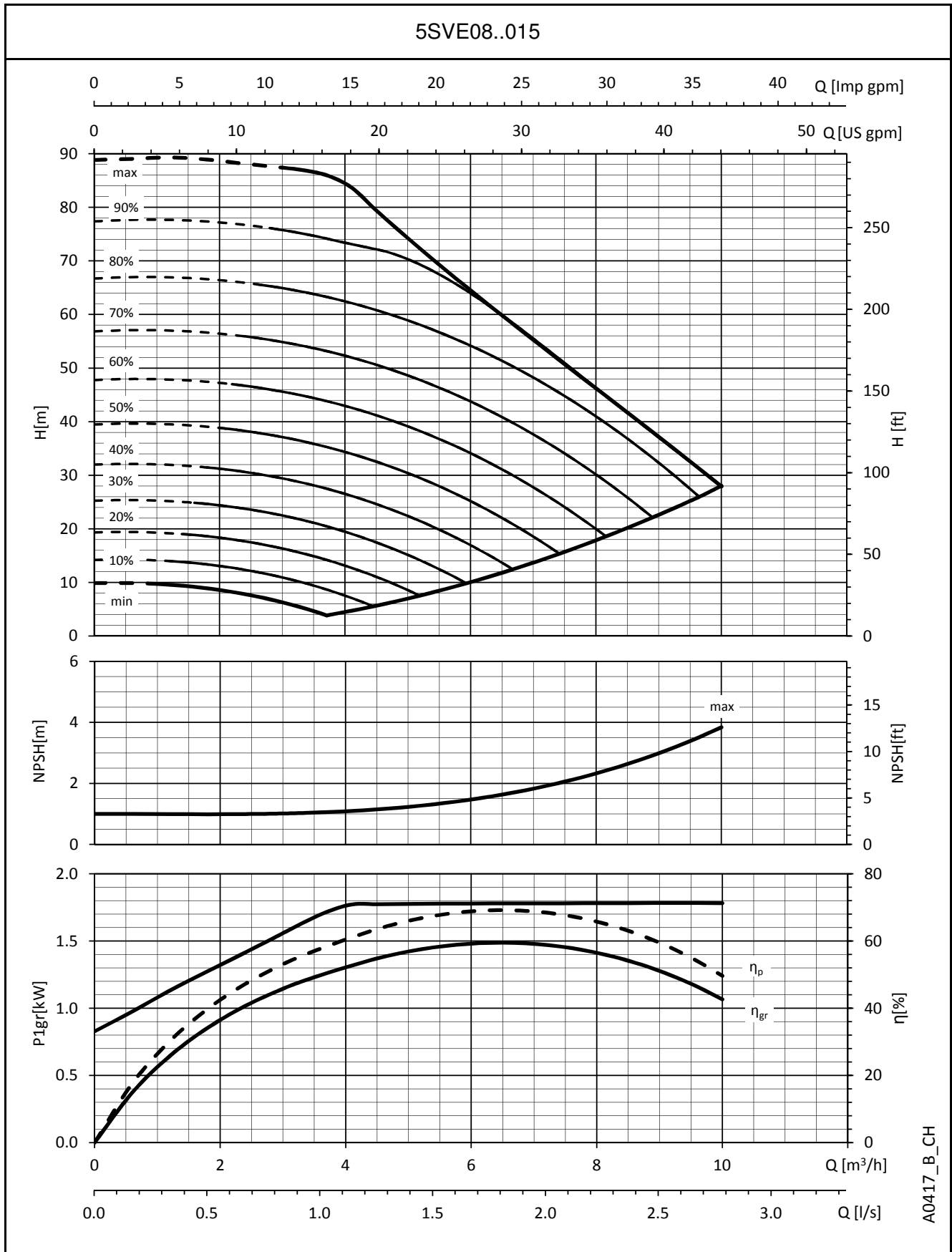

A0417_B_CH

The performances are valid for liquid with density $\rho = 1.0 \text{ Kg/dm}^3$ and kinematic viscosity $\nu = 1 \text{ mm}^2/\text{sec}$.

**5SVE SERIES
OPERATING CHARACTERISTICS**

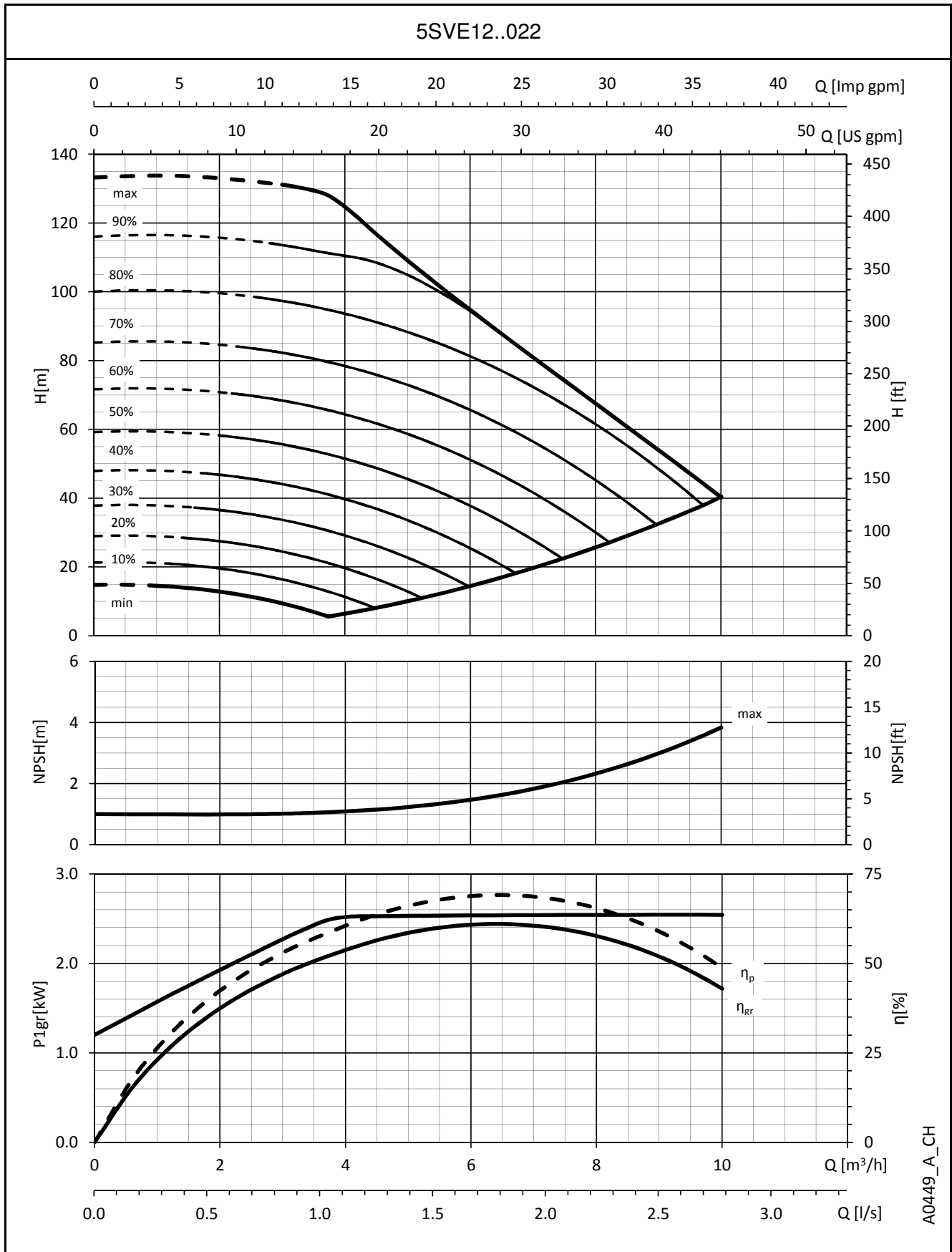

The performances are valid for liquid with density $\rho = 1.0 \text{ Kg/dm}^3$ and kinematic viscosity $\nu = 1 \text{ mm}^2/\text{sec}$.

10, 15, 22SVE..F SERIES - SINGLE PHASE VERSION DIMENSIONS AND WEIGHTS

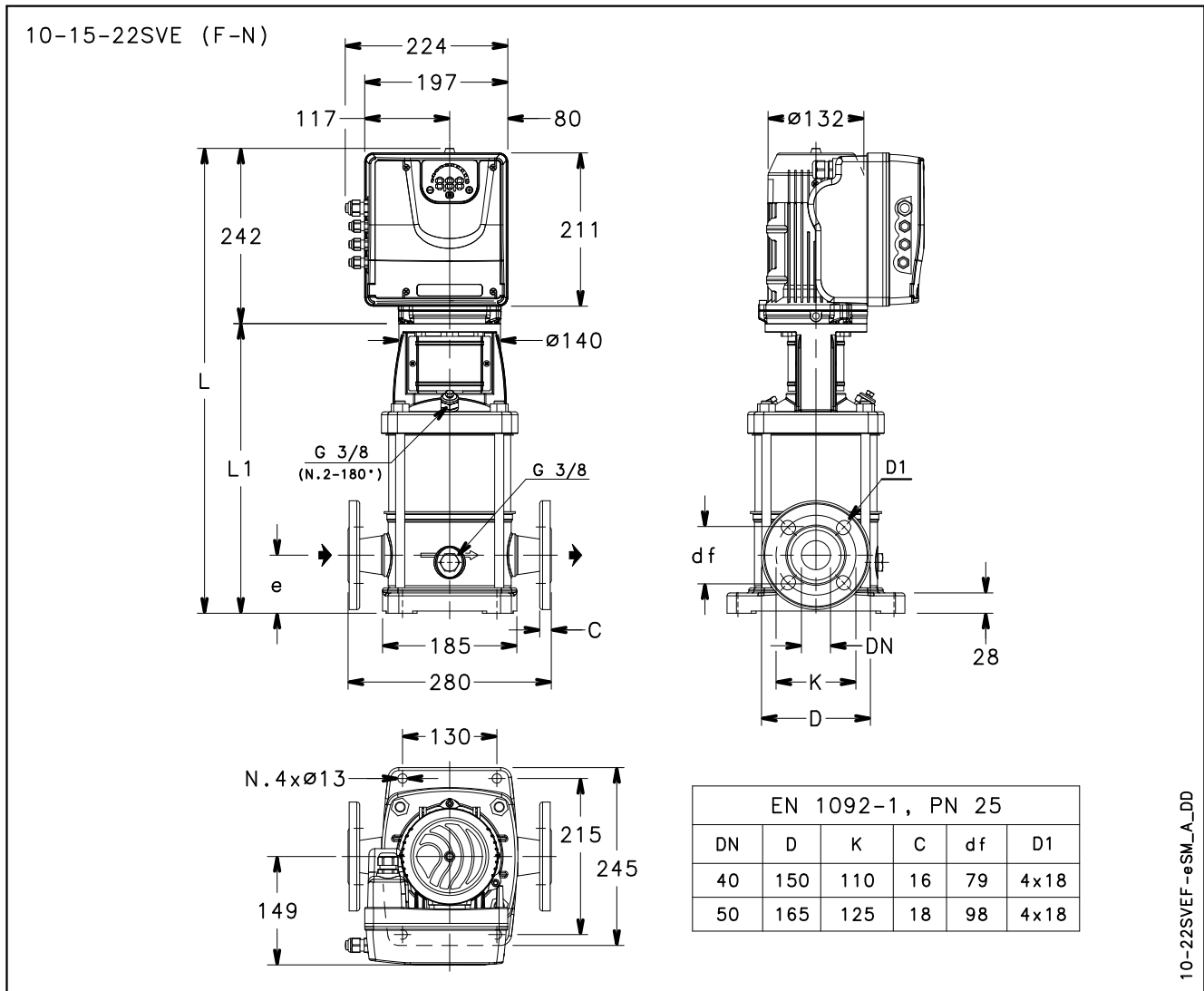

PUMP TYPE SVE F (SINGLE-PHASE)	MOTOR		DIMENSIONS (mm)				WEIGHT (kg)	
	kW	SIZE	L	L1	e	DN	PUMP	ELECTRIC PUMP
10SVE01F005POM	0,55	90	609	367	80	40	14,6	22,1
10SVE02F007POM	0,75	90	609	367	80	40	15,5	23,0
10SVE02F011POM	1,1	90	609	367	80	40	15,5	24,4
10SVE03F015POM	1,5	90	641	399	80	40	16,5	25,4
15SVE01F007POM	0,75	90	661	419	90	50	15,4	22,9
15SVE01F011POM	1,1	90	661	419	90	50	15,4	24,3
15SVE02F015POM	1,5	90	661	419	90	50	16,8	25,7
22SVE01F007POM	0,75	90	661	419	90	50	15,4	22,9
22SVE01F011POM	1,1	90	661	419	90	50	15,4	24,3
22SVE02F015POM	1,5	90	661	419	90	50	16,8	25,7

10-22svef-esm-2p50-en_a_td

10, 15, 22SVE..F SERIES - THREE PHASE VERSION DIMENSIONS AND WEIGHTS

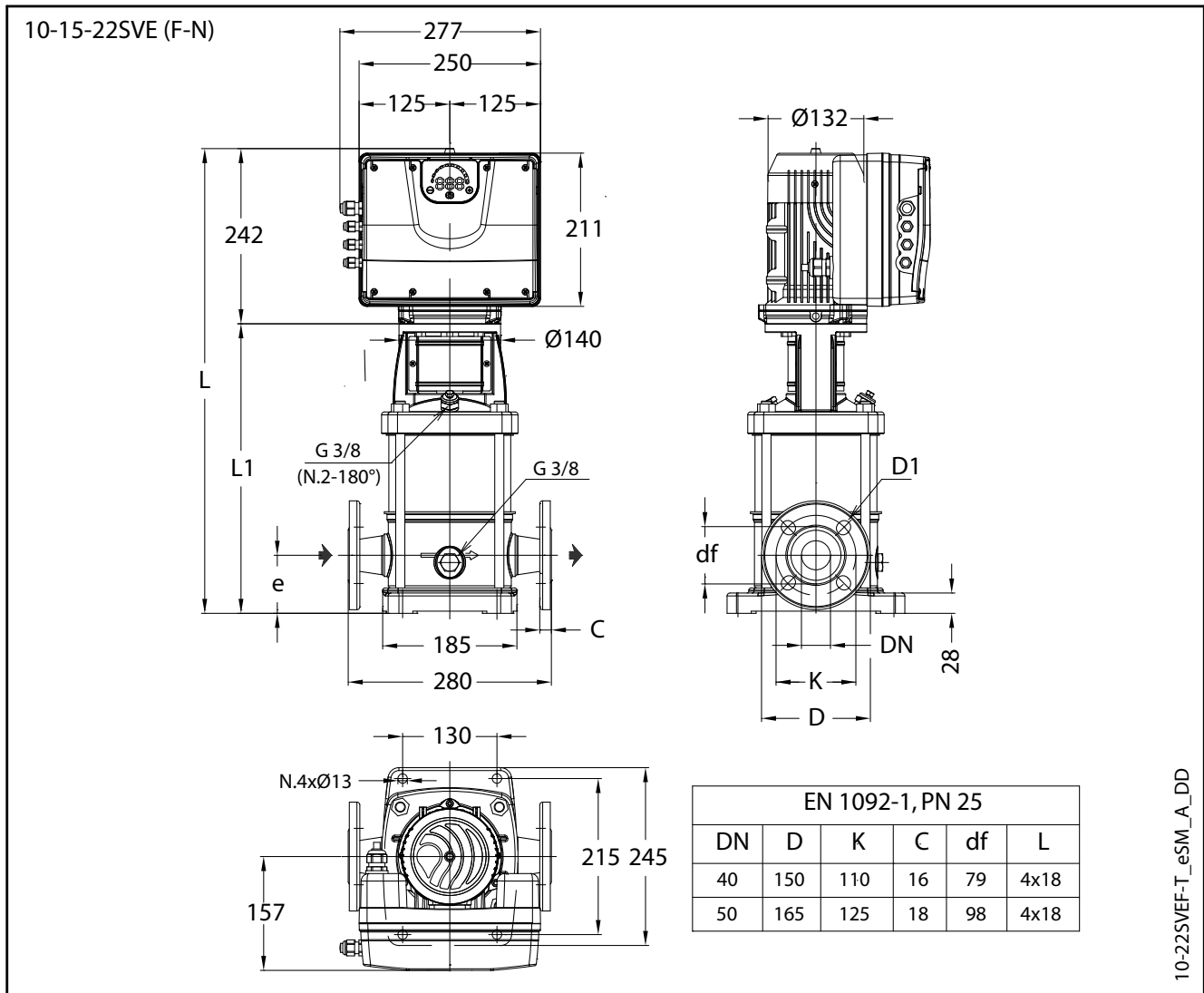

PUMP TYPE SVE F (THREE-PHASE)	MOTOR		DIMENSIONS (mm)				WEIGHT (kg)	
	kW	SIZE	L	L1	e	DN	PUMP	ELECTRIC PUMP
10SVE01F005POT	0,55	90	609	367	80	40	14,6	27,7
10SVE02F007POT	0,75	90	609	367	80	40	15,5	28,6
10SVE02F011POT	1,1	90	609	367	80	40	15,5	30
10SVE03F015POT	1,5	90	641	399	80	40	16,5	31,0
10SVE04F022POT	2,2	90	673	431	80	40	17,5	33,5
15SVE01F007POT	0,75	90	661	419	90	50	15,4	28,5
15SVE01F011POT	1,1	90	661	419	90	50	15,4	29,9
15SVE02F015POT	1,5	90	661	419	90	50	16,8	31,3
15SVE02F022POT	2,2	90	661	419	90	50	18,2	34,2
22SVE01F007POT	0,75	90	661	419	90	50	15,4	28,5
22SVE01F011POT	1,1	90	661	419	90	50	15,4	29,9
22SVE02F015POT	1,5	90	661	419	90	50	16,8	31,3
22SVE02F022POT	2,2	90	661	419	90	50	16,8	32,8

10-22svef-esm-2p50T-en_a_td

10, 15, 22SVE..T SERIES - SINGLE PHASE VERSION DIMENSIONS AND WEIGHTS

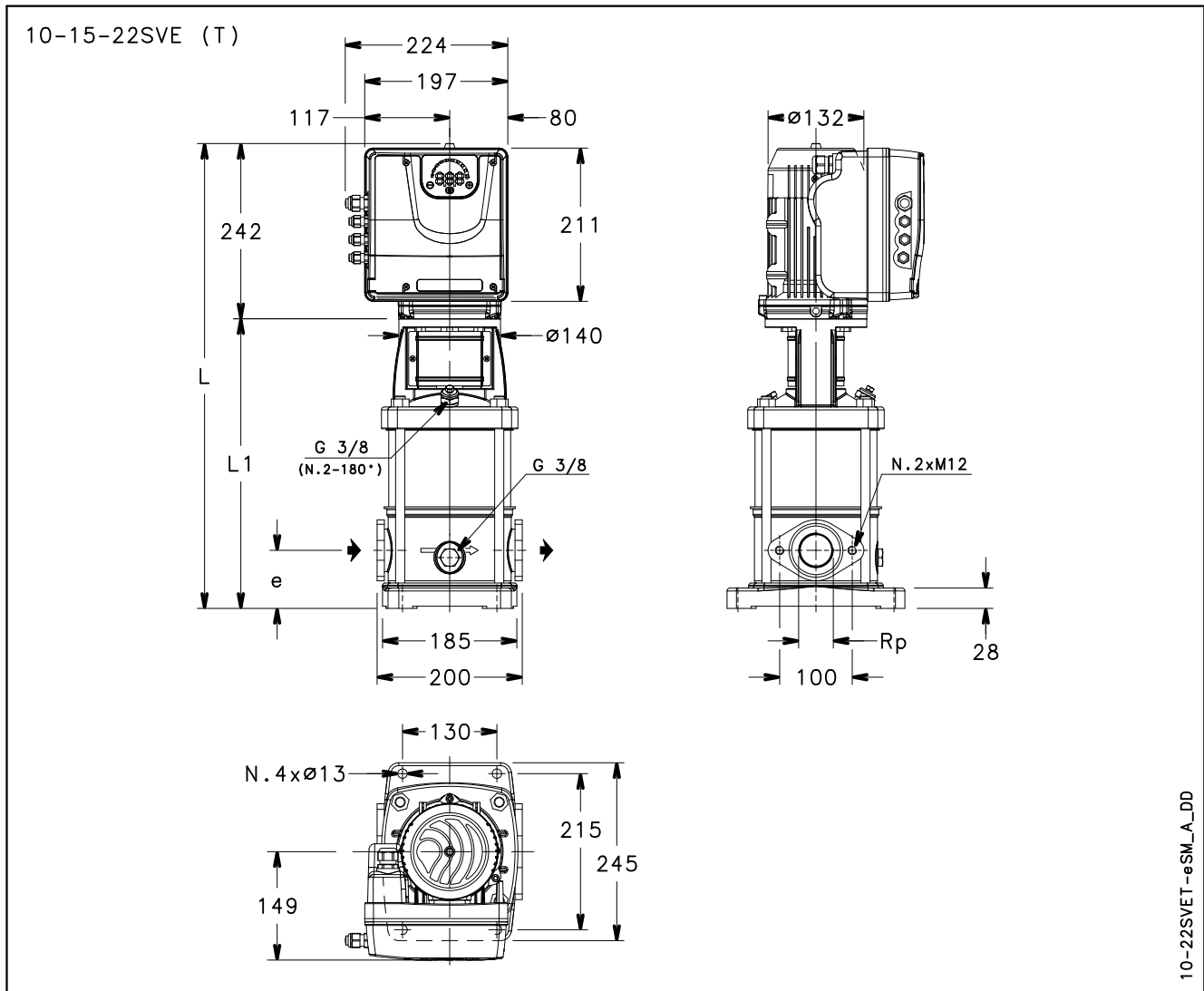

PUMP TYPE SVE T (SINGLE-PHASE)	MOTOR		DIMENSIONS (mm)				WEIGHT (kg)	
	kW	SIZE	L	L1	e	Rp	PUMP	ELECTRIC PUMP
10SVE01T005P0M	0,55	90	609	367	80	1 1/2	14,1	21,6
10SVE02T007P0M	0,75	90	609	367	80	1 1/2	15	22,5
10SVE02T011P0M	1,1	90	609	367	80	1 1/2	15	23,9
10SVE03T015P0M	1,5	90	641	399	80	1 1/2	16	24,9
15SVE01T007P0M	0,75	90	651	409	90	2	14,1	21,6
15SVE01T011P0M	1,1	90	651	409	90	2	14,1	23
15SVE02T015P0M	1,5	90	651	409	90	2	15,5	24,4
22SVE01T007P0M	0,75	90	651	409	90	2	14,1	21,6
22SVE01T011P0M	1,1	90	651	409	90	2	14,1	23
22SVE02T015P0M	1,5	90	651	409	90	2	15,5	24,4

10-22sveT-esm-2p50-en_a_td

10, 15, 22SVE..T SERIES - THREE PHASE VERSION DIMENSIONS AND WEIGHTS

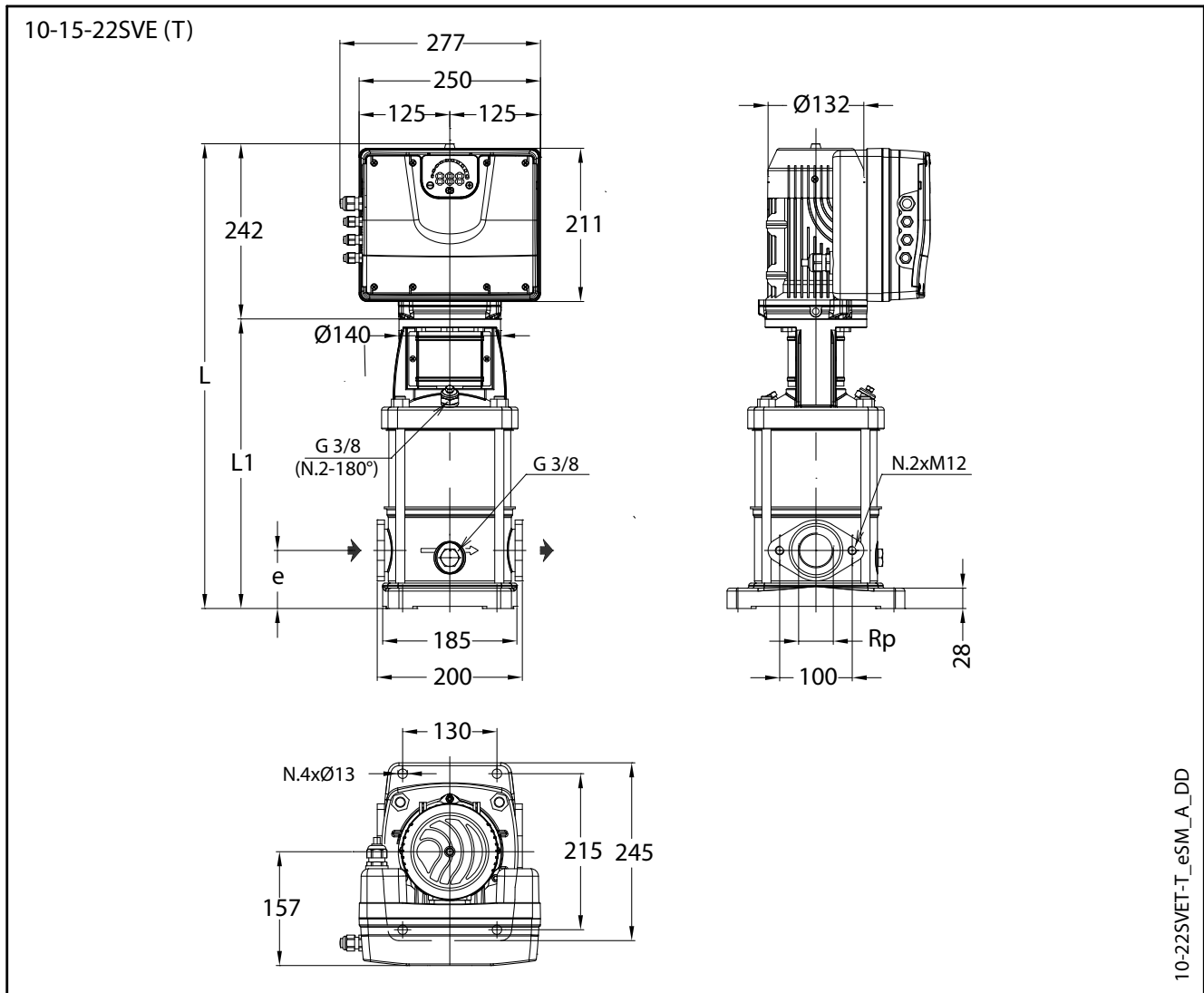

PUMP TYPE SVE T (THREE-PHASE)	MOTOR		DIMENSIONS (mm)				WEIGHT (kg)	
	kW	SIZE	L	L1	e	Rp	PUMP	ELECTRIC PUMP
10SVE01T005POT	0,55	90	609	367	80	1 1/2	14,1	27,1
10SVE02T007POT	0,75	90	609	367	80	1 1/2	15	28
10SVE02T011POT	1,1	90	609	367	80	1 1/2	15	29,4
10SVE03T015POT	1,5	90	641	399	80	1 1/2	16	30,4
10SVE04T022POT	2,2	90	673	431	80	1 1/2	17	32
15SVE01T007POT	0,75	90	651	409	90	2	14,1	27,1
15SVE01T011POT	1,1	90	651	409	90	2	14,1	28,5
15SVE02T015POT	1,5	90	651	409	90	2	15,5	29,9
15SVE02T022POT	2,2	90	651	409	90	2	15,5	31,5
22SVE01T007POT	0,75	90	651	409	90	2	14,1	27,1
22SVE01T011POT	1,1	90	651	409	90	2	14,1	28,5
22SVE02T015POT	1,5	90	651	409	90	2	15,5	29,9
22SVE02T022POT	2,2	90	651	409	90	2	15,5	31,5

10-22sveT-esm-2p50-en_a_td

10SVE SERIES OPERATING CHARACTERISTICS

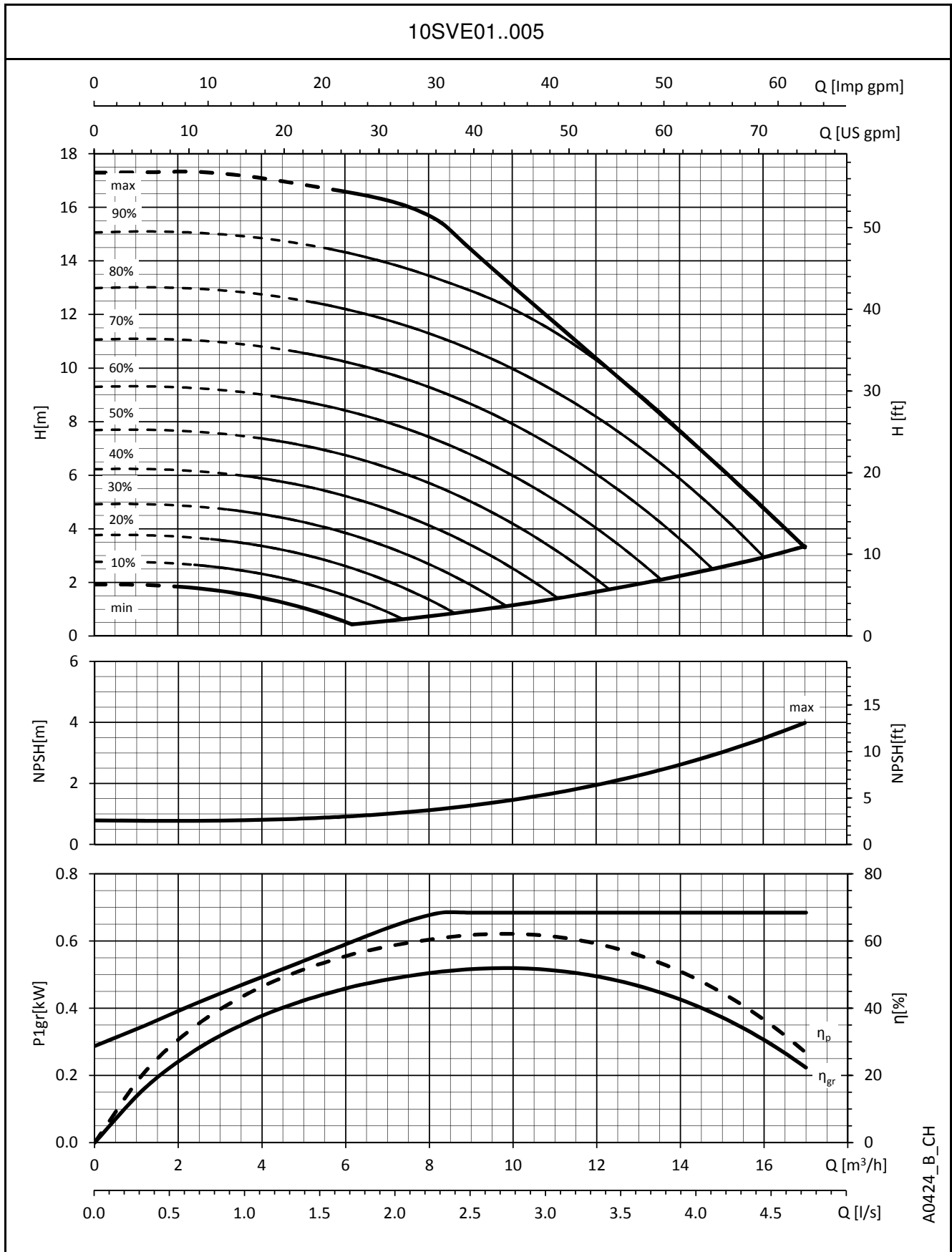

A0424_B_CH

The performances are valid for liquid with density $\rho = 1.0 \text{ Kg/dm}^3$ and kinematic viscosity $\nu = 1 \text{ mm}^2/\text{sec}$.

10SVE SERIES OPERATING CHARACTERISTICS

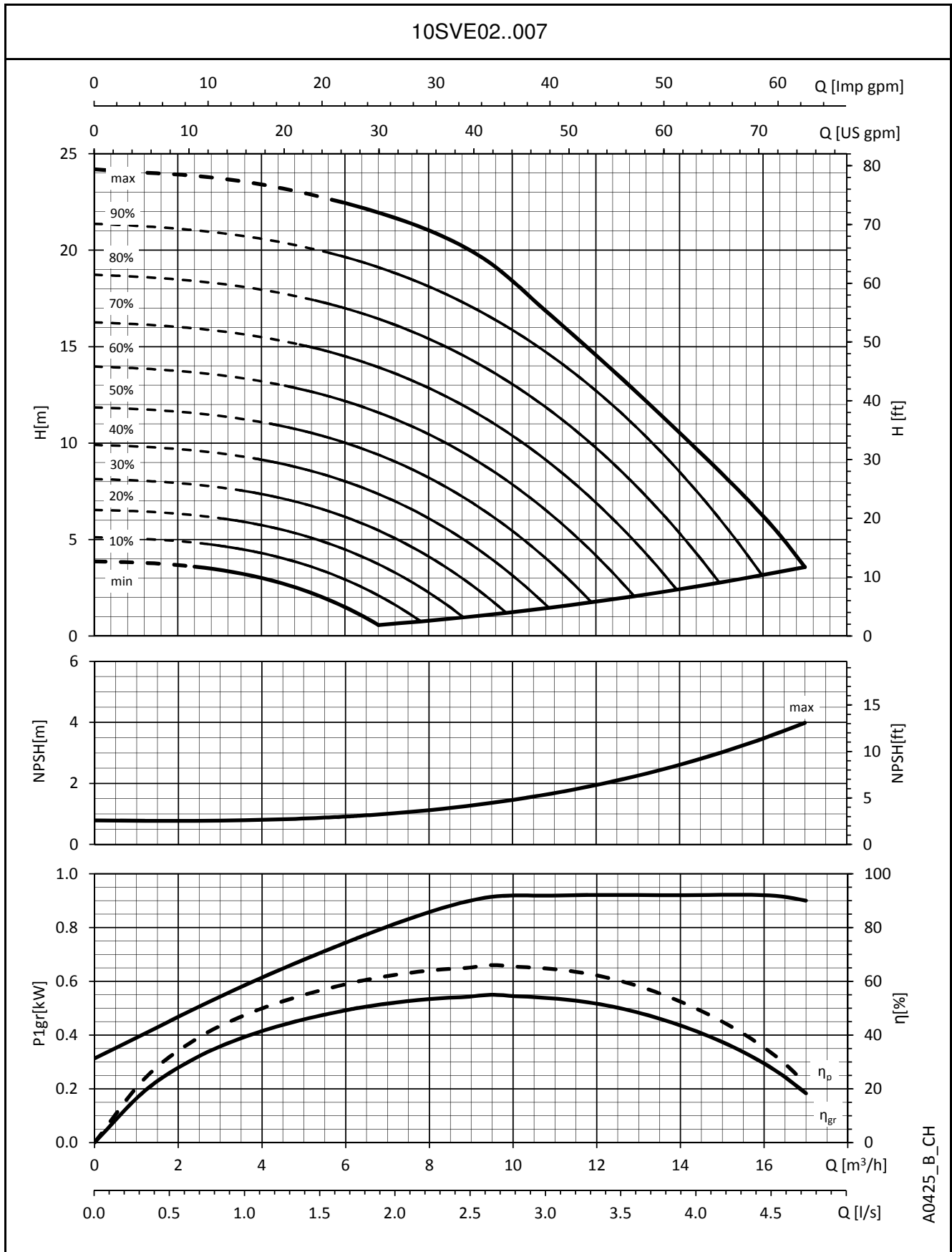

A0425_B_CH

The performances are valid for liquid with density $\rho = 1.0 \text{ Kg/dm}^3$ and kinematic viscosity $\nu = 1 \text{ mm}^2/\text{sec}$.

10SVE SERIES OPERATING CHARACTERISTICS

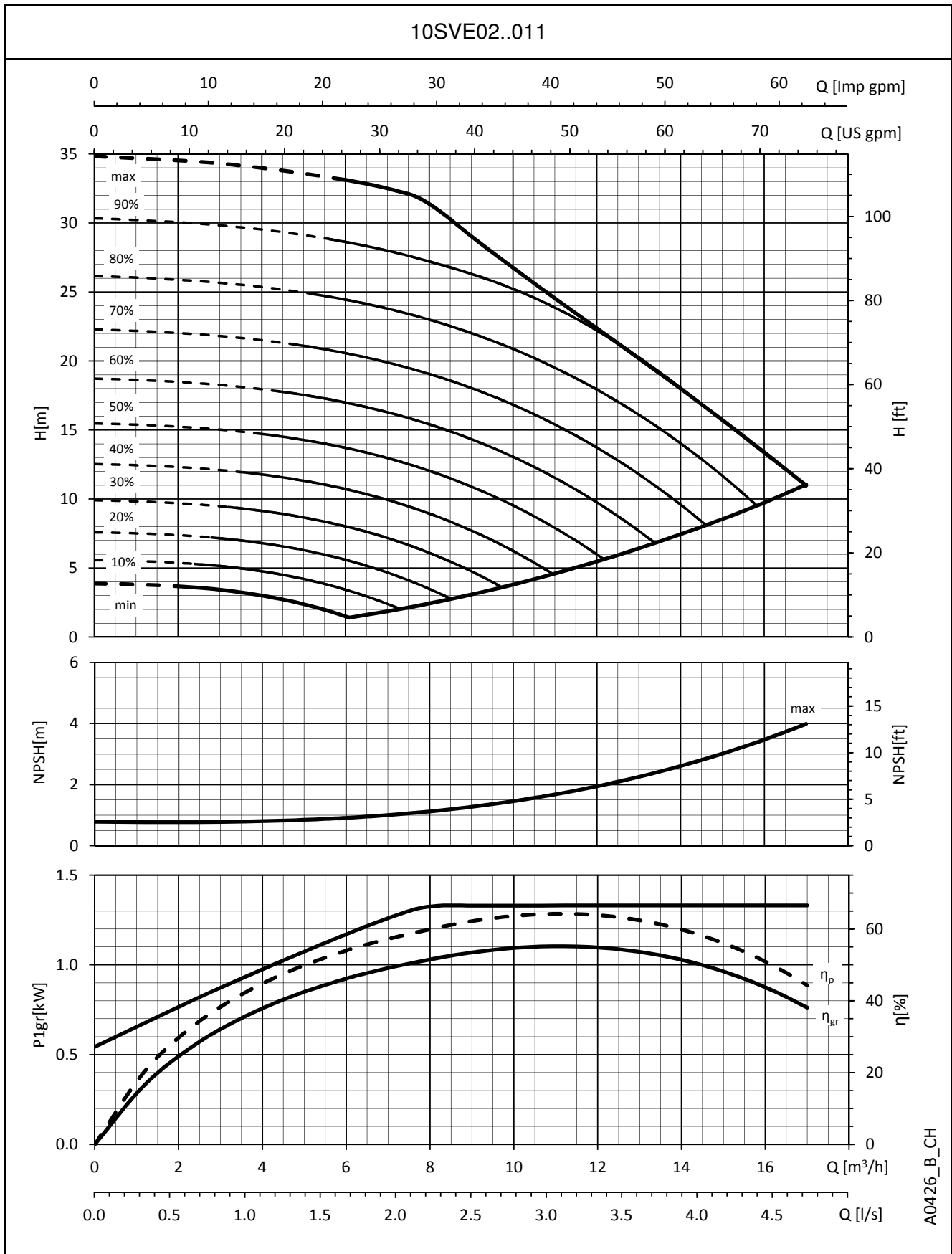

A0426_B_CH

The performances are valid for liquid with density $\rho = 1.0 \text{ Kg/dm}^3$ and kinematic viscosity $\nu = 1 \text{ mm}^2/\text{sec}$.

10SVE SERIES OPERATING CHARACTERISTICS

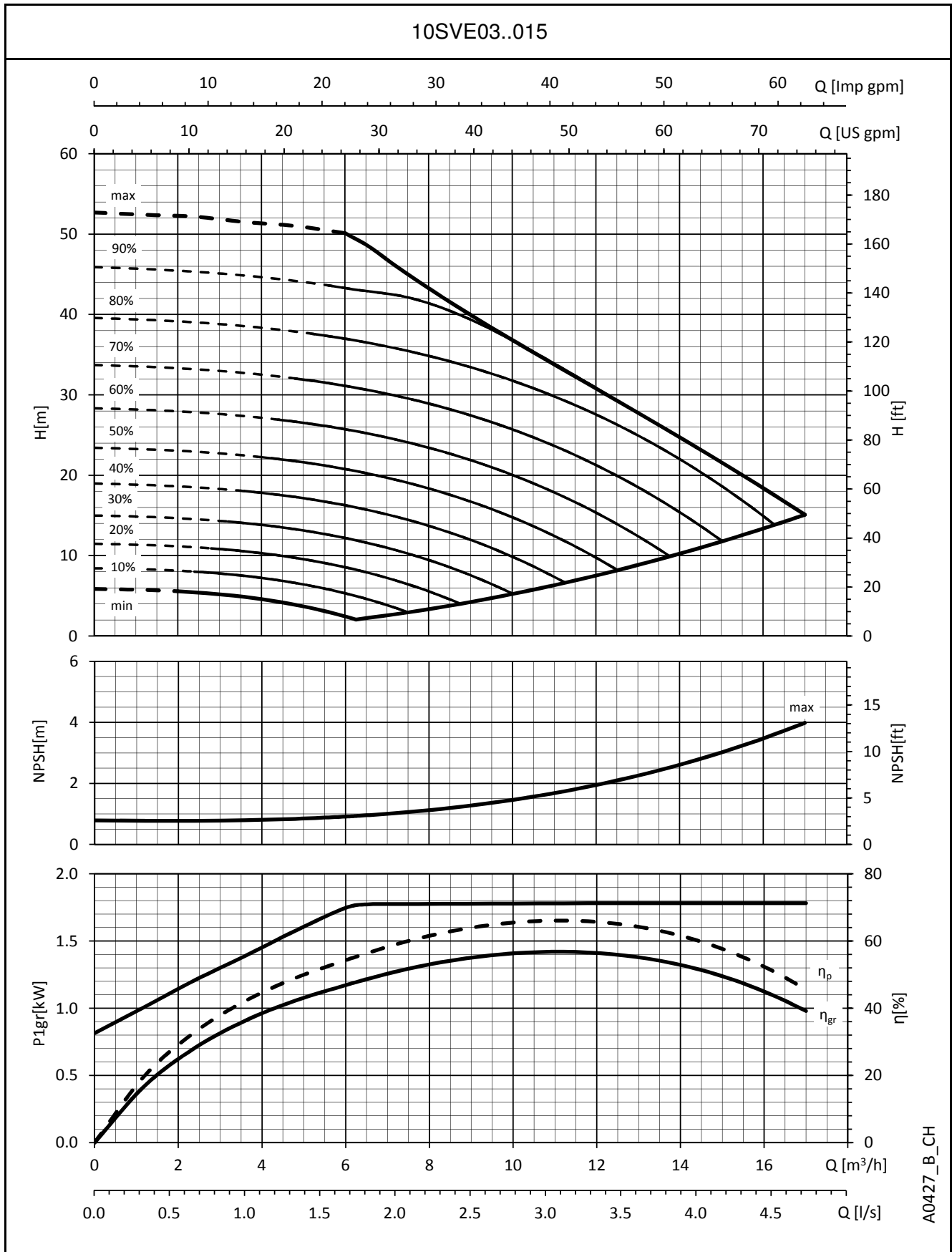

A0427_B_CH

The performances are valid for liquid with density $\rho = 1.0 \text{ Kg/dm}^3$ and kinematic viscosity $\nu = 1 \text{ mm}^2/\text{sec}$.

10SVE SERIES OPERATING CHARACTERISTICS

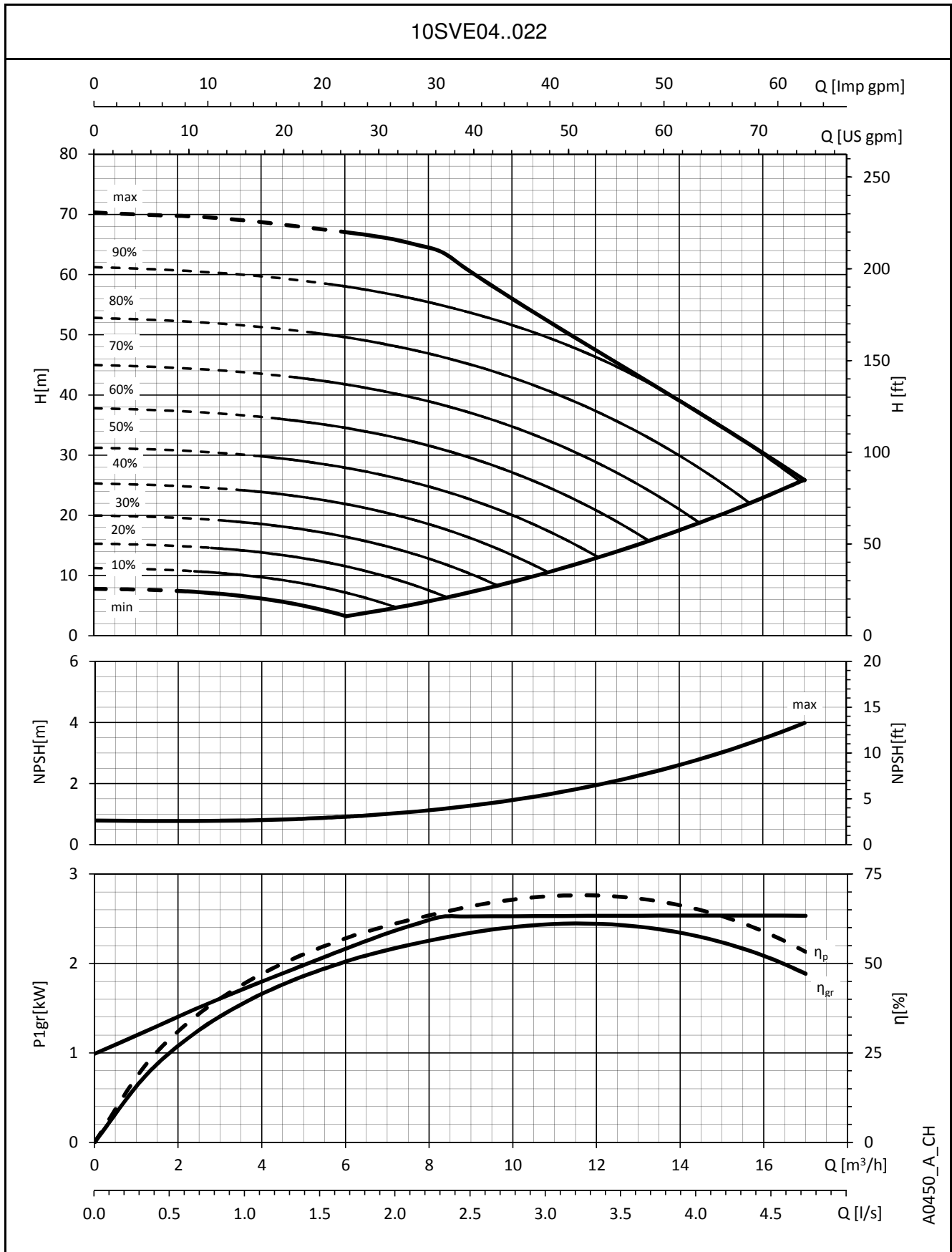

A0450_A_CH

The performances are valid for liquid with density $\rho = 1.0 \text{ Kg/dm}^3$ and kinematic viscosity $\nu = 1 \text{ mm}^2/\text{sec}$.

15SVE SERIES OPERATING CHARACTERISTICS

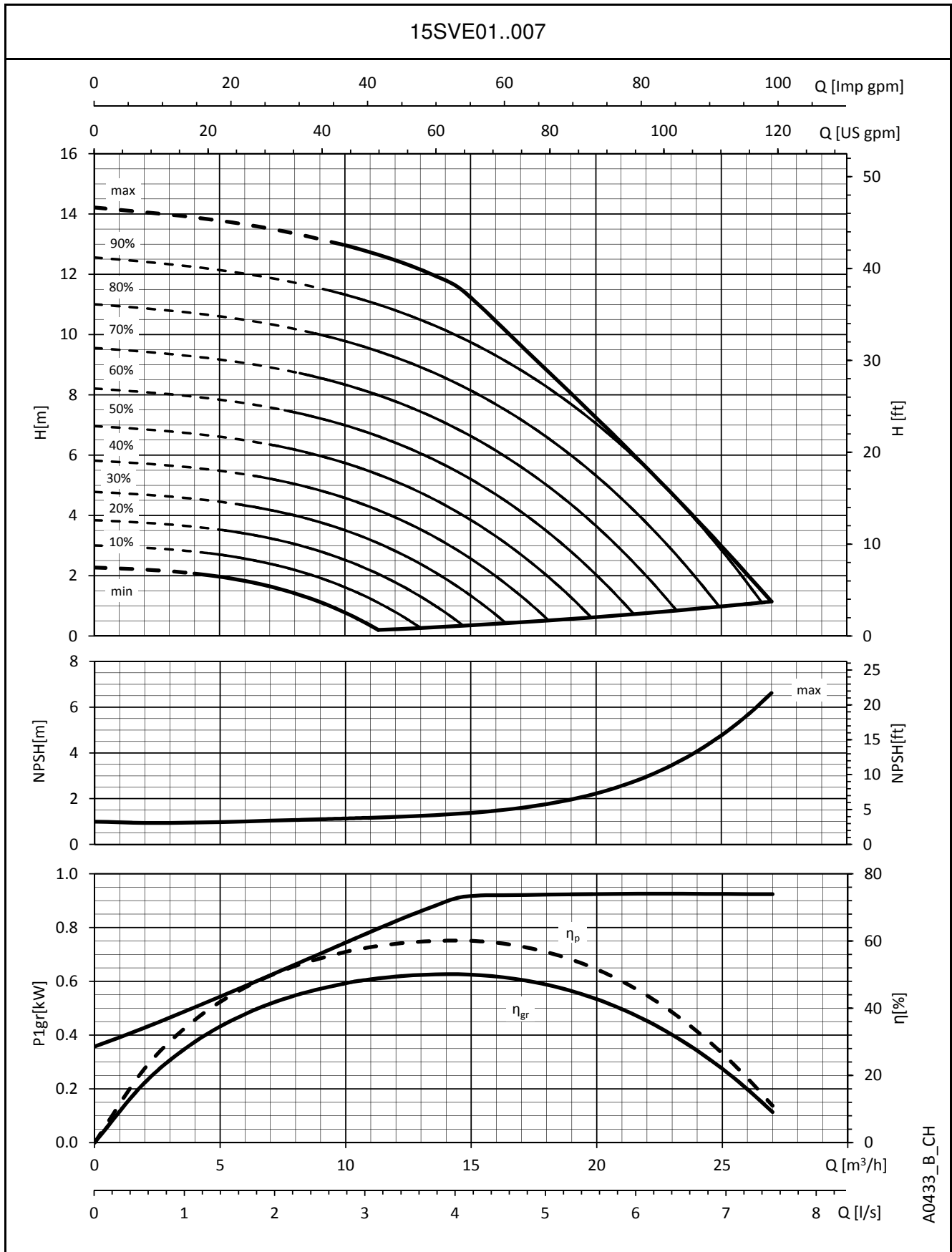

A0433_B_CH

The performances are valid for liquid with density $\rho = 1.0 \text{ Kg/dm}^3$ and kinematic viscosity $\nu = 1 \text{ mm}^2/\text{sec}$.

15SVE SERIES OPERATING CHARACTERISTICS

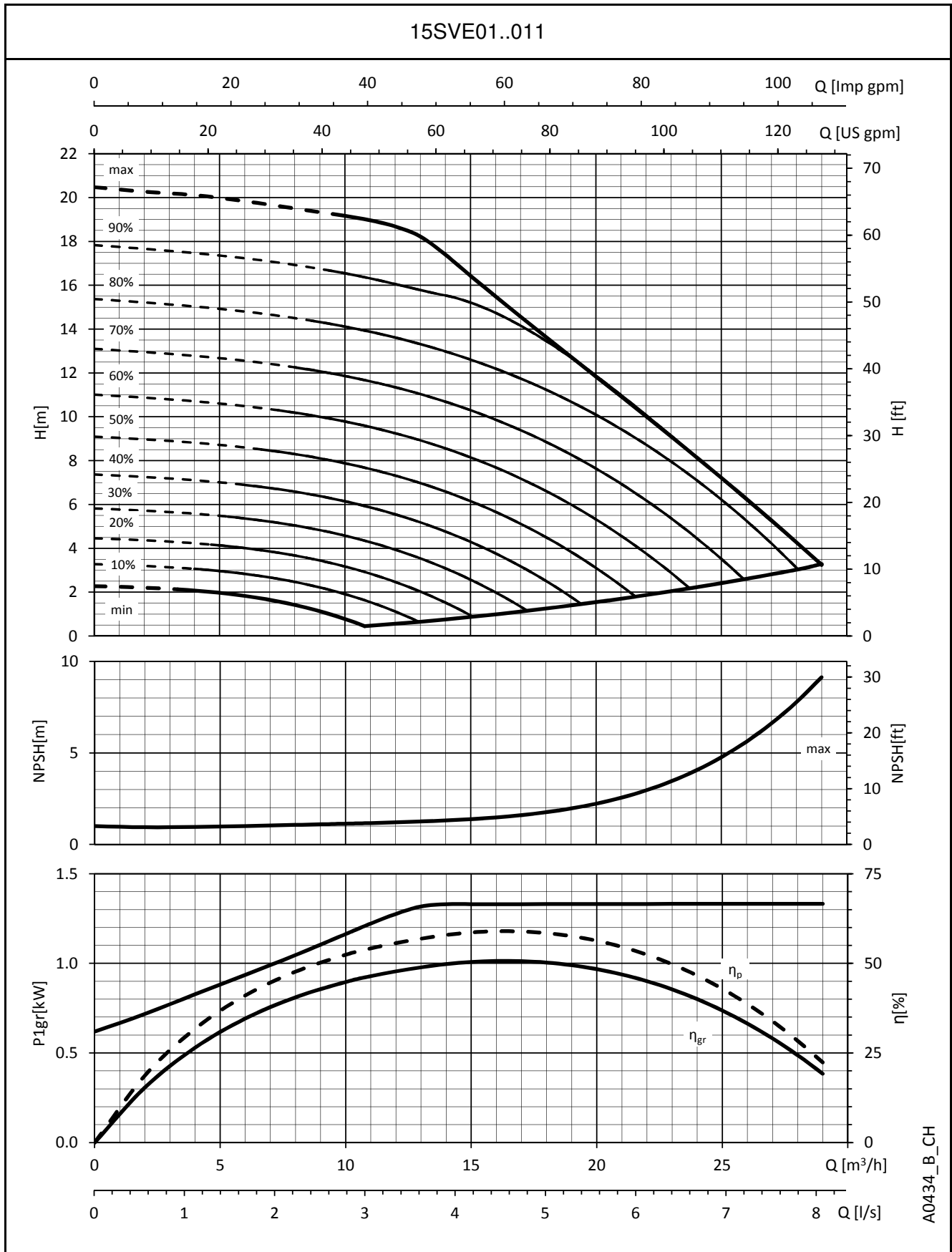

A0434_B_CH

The performances are valid for liquid with density $\rho = 1.0 \text{ Kg/dm}^3$ and kinematic viscosity $\nu = 1 \text{ mm}^2/\text{sec}$.

**15SVE SERIES
OPERATING CHARACTERISTICS**

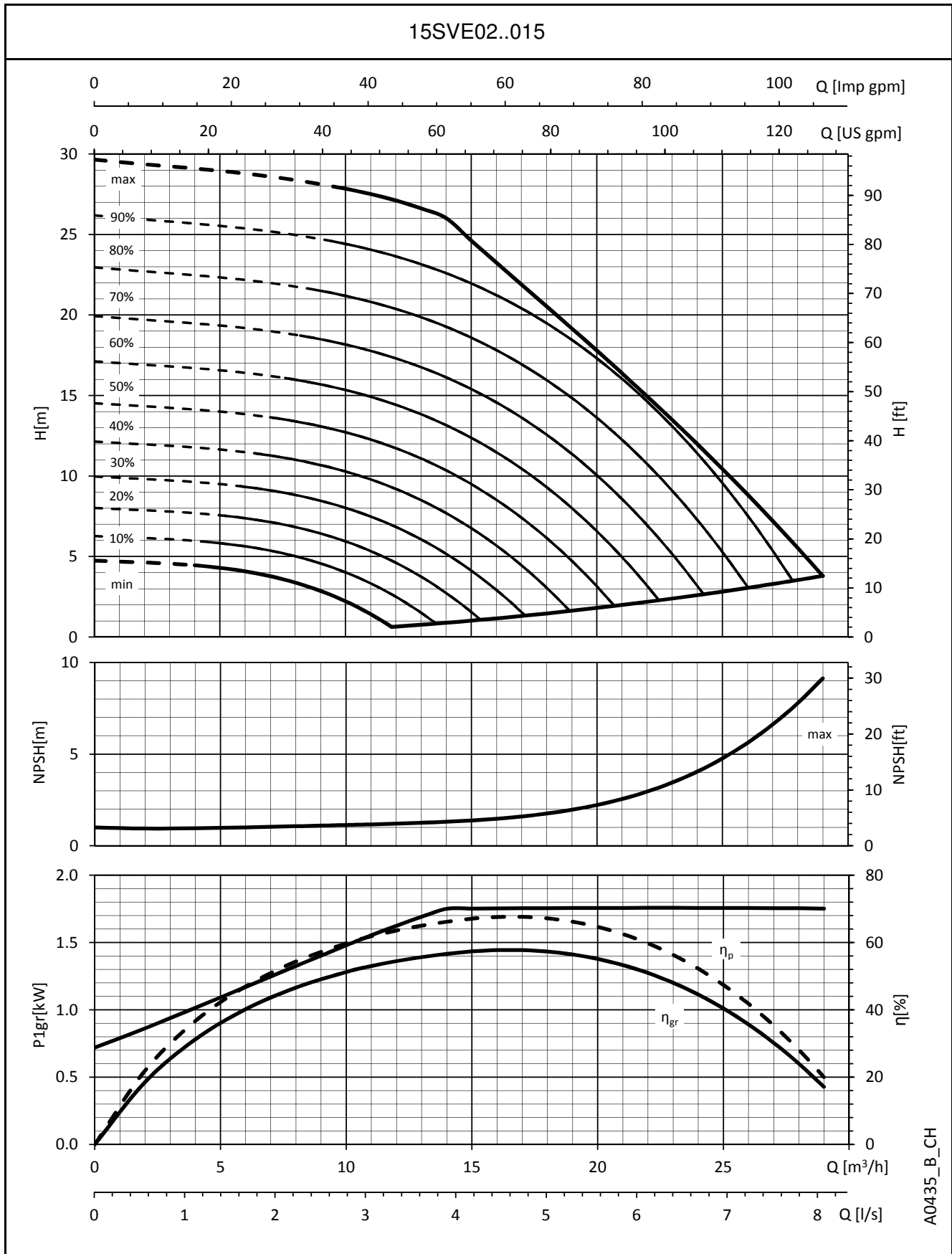

A0435_B_CH

The performances are valid for liquid with density $\rho = 1.0 \text{ Kg/dm}^3$ and kinematic viscosity $\nu = 1 \text{ mm}^2/\text{sec}$.

**15SVE SERIES
OPERATING CHARACTERISTICS**

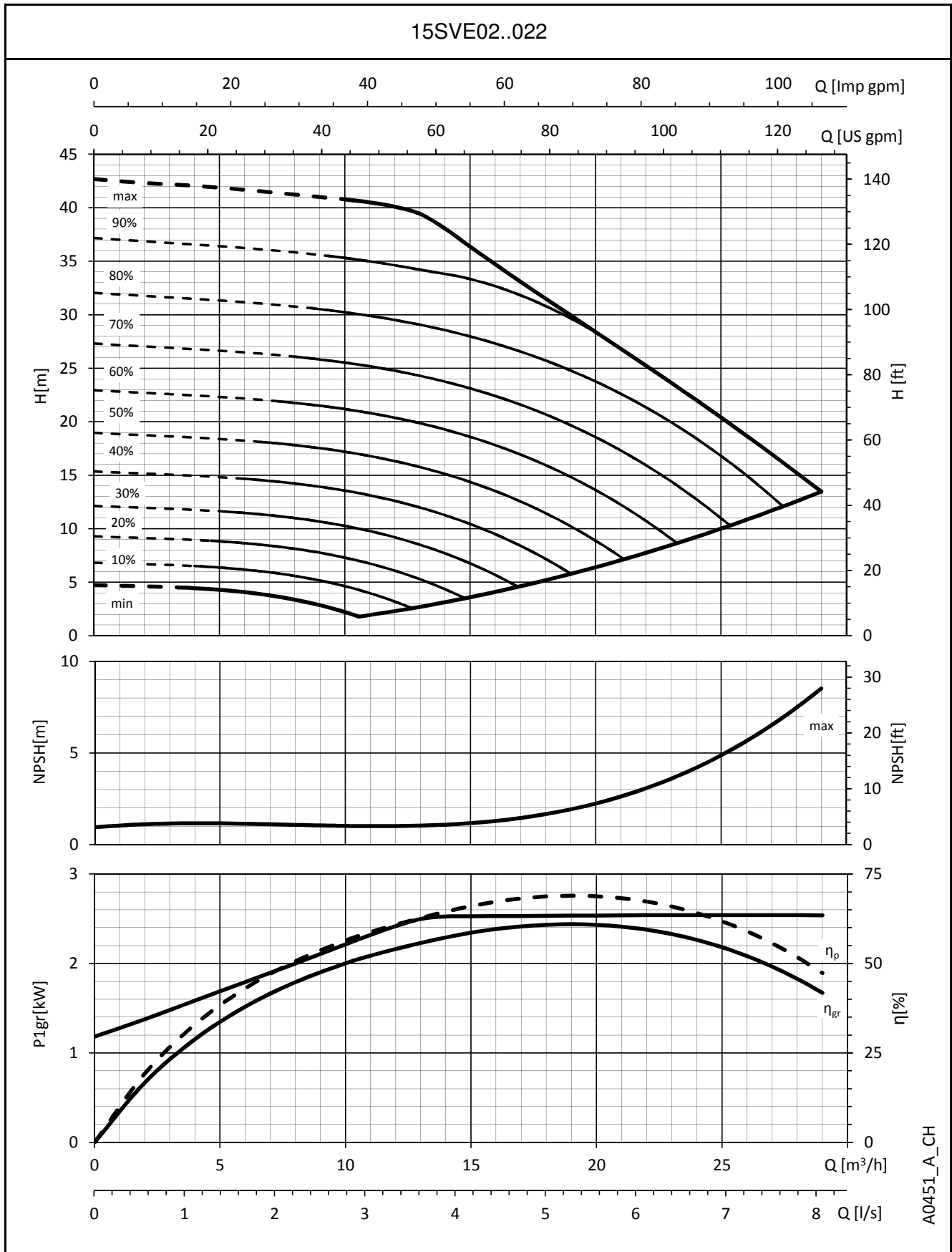

The performances are valid for liquid with density $\rho = 1.0 \text{ Kg/dm}^3$ and kinematic viscosity $\nu = 1 \text{ mm}^2/\text{sec}$.

**22SVE SERIES
OPERATING CHARACTERISTICS**

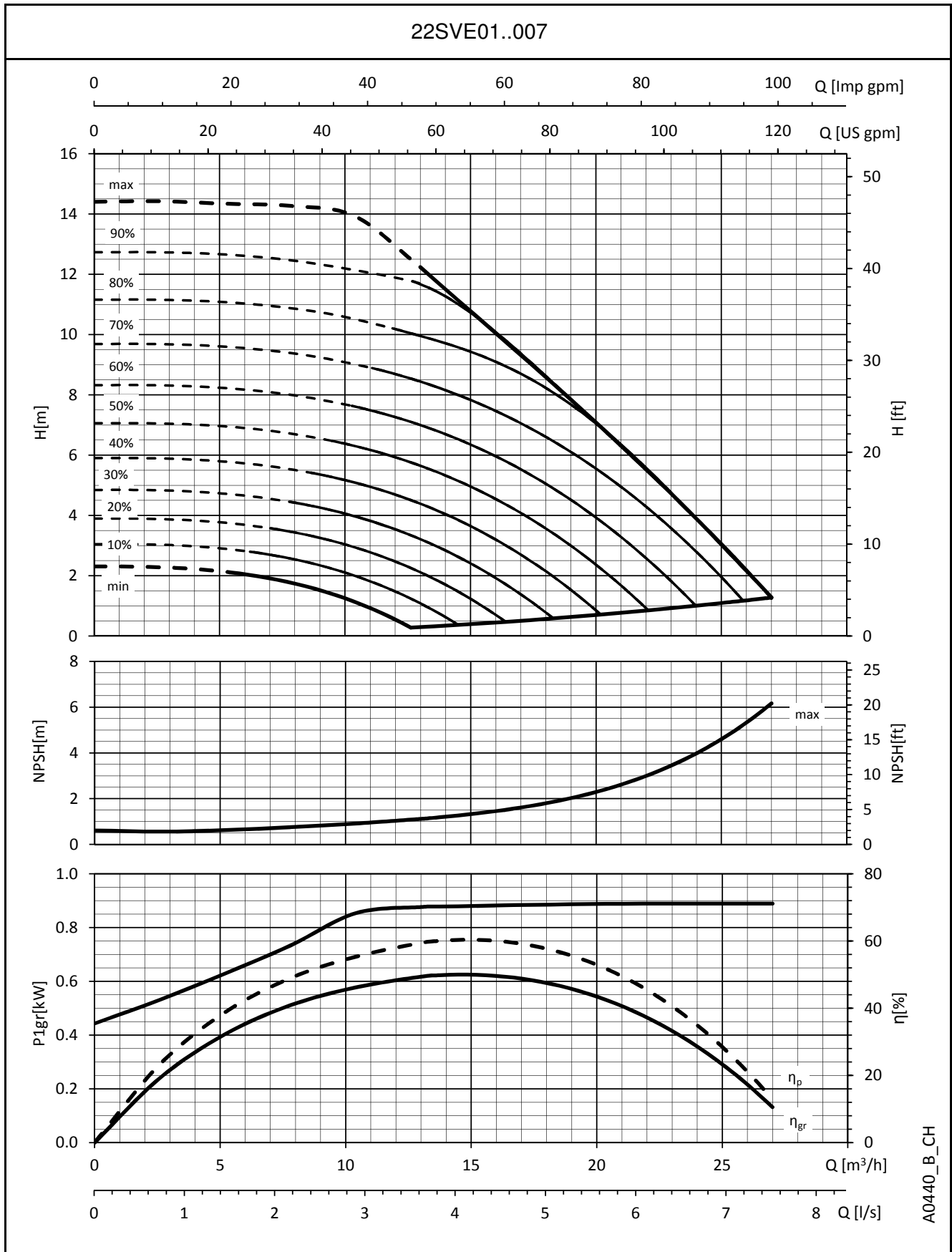

A0440_B_CH

The performances are valid for liquid with density $\rho = 1.0 \text{ Kg/dm}^3$ and kinematic viscosity $\nu = 1 \text{ mm}^2/\text{sec}$.

22SVE SERIES OPERATING CHARACTERISTICS

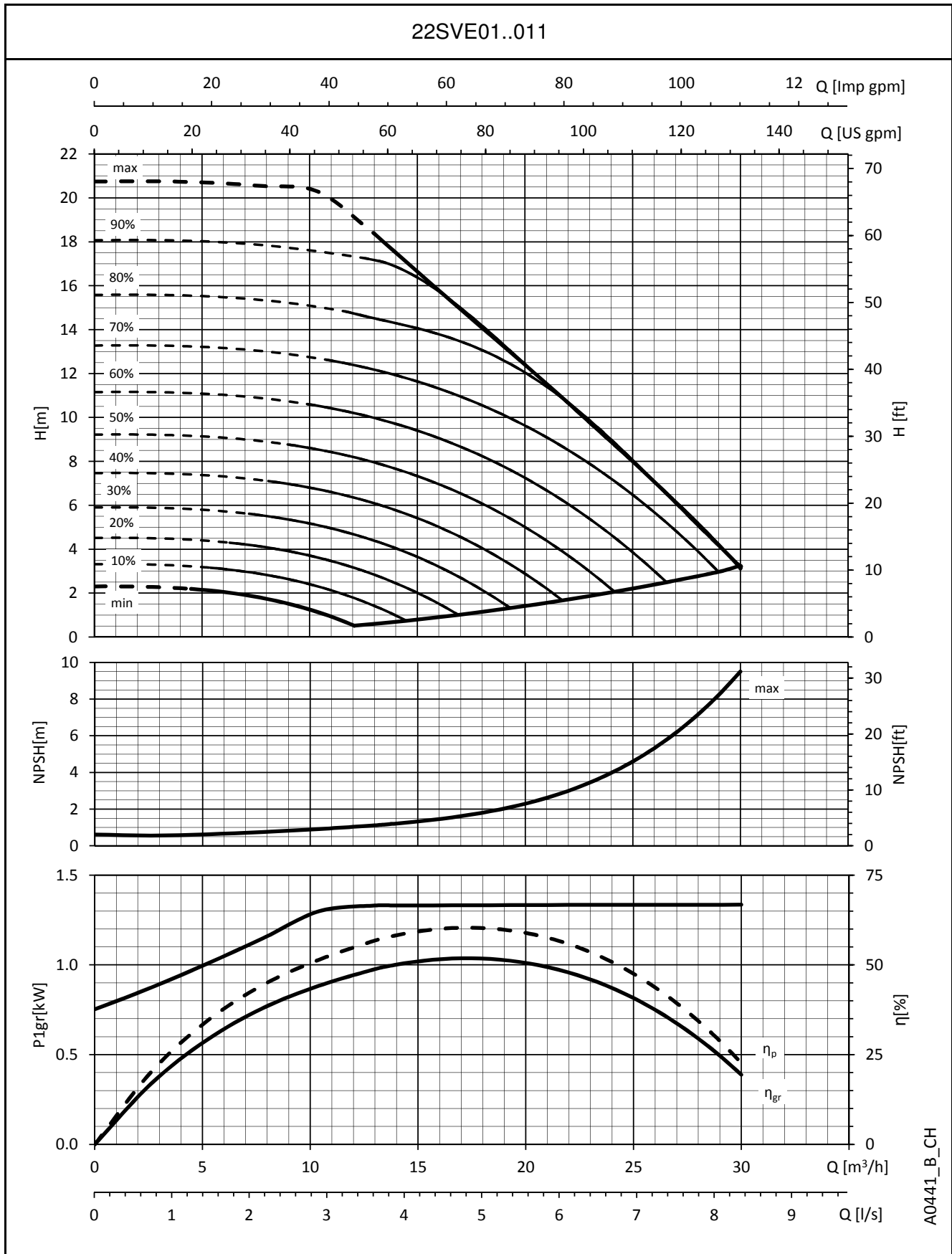

A0441_B_CH

The performances are valid for liquid with density $\rho = 1.0 \text{ Kg/dm}^3$ and kinematic viscosity $\nu = 1 \text{ mm}^2/\text{sec}$.

22SVE SERIES OPERATING CHARACTERISTICS

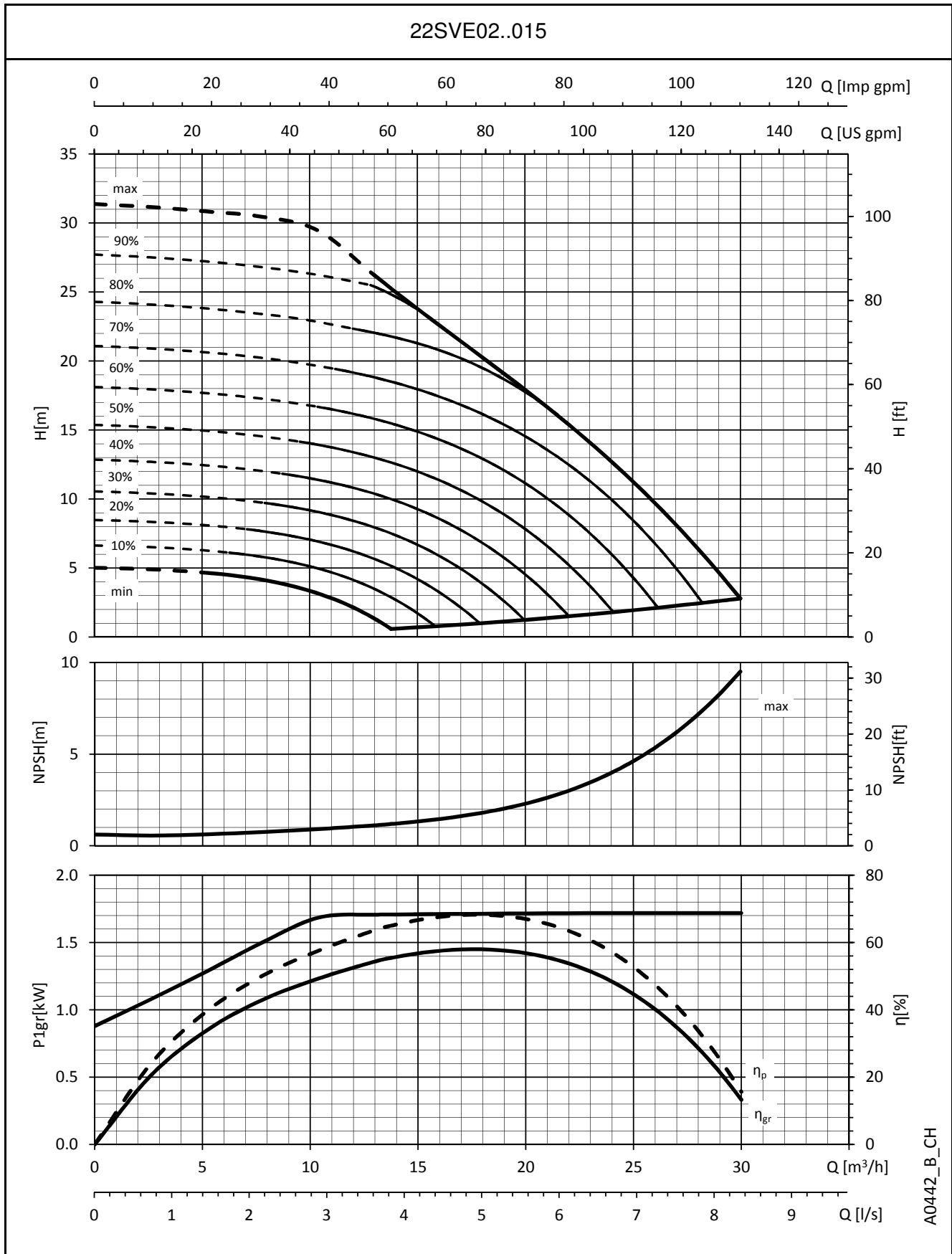

A0442_B_CH

The performances are valid for liquid with density $\rho = 1.0 \text{ Kg/dm}^3$ and kinematic viscosity $\nu = 1 \text{ mm}^2/\text{sec}$.

**22SVE SERIES
OPERATING CHARACTERISTICS**

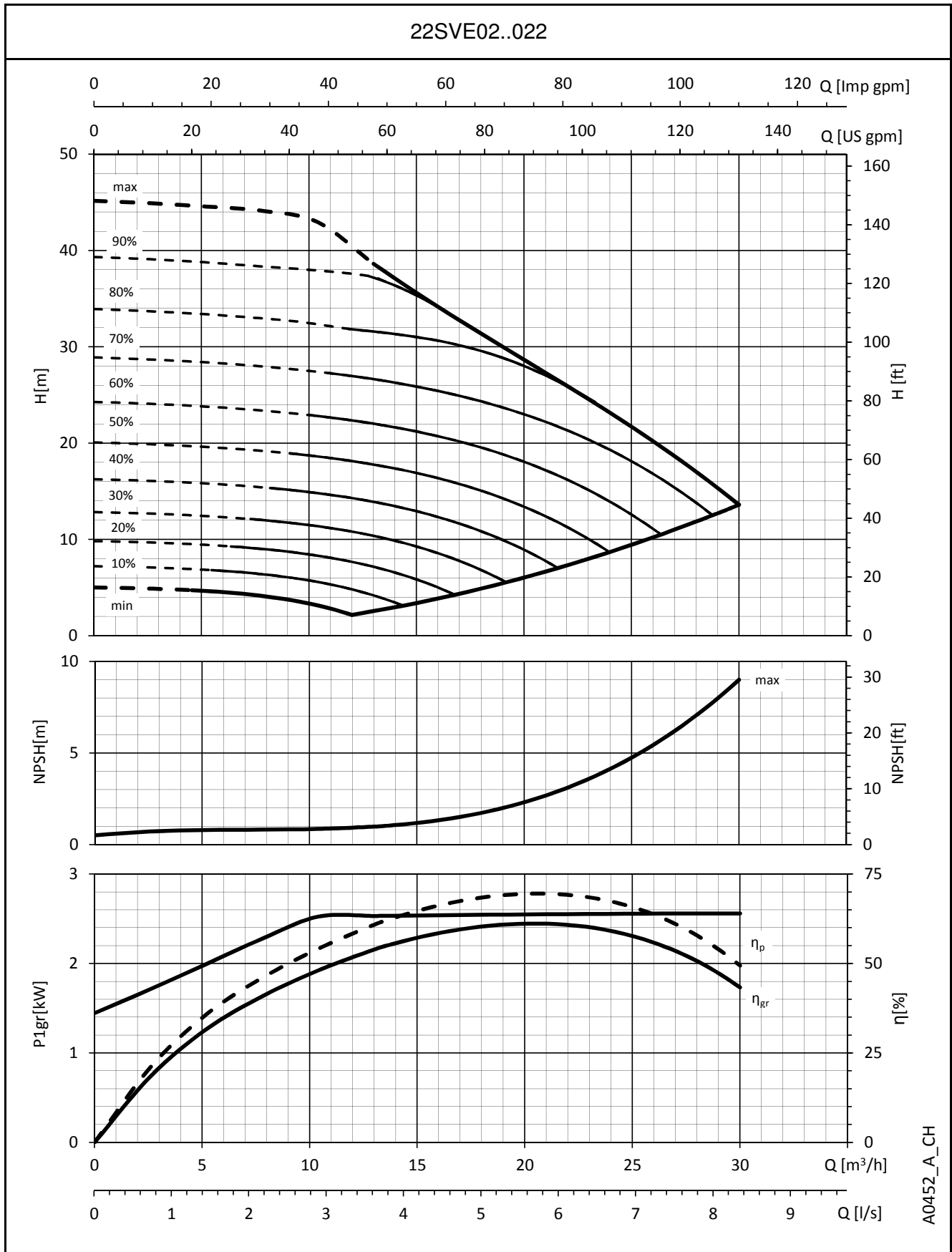

A0452_A_CH

The performances are valid for liquid with density $\rho = 1.0 \text{ Kg/dm}^3$ and kinematic viscosity $\nu = 1 \text{ mm}^2/\text{sec}$.

ACCESSORIES

G/SVH KIT TABLE OF COMPONENTS

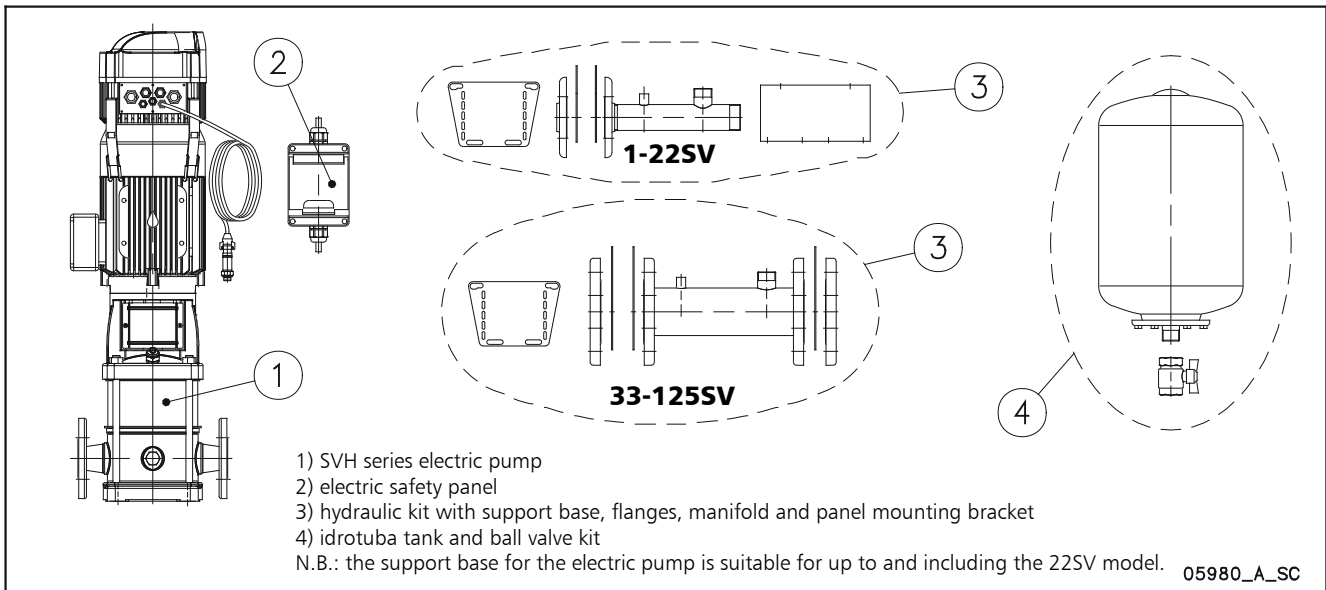

(1) PUMP TYPE	KW	VOLTAGE	(2) ELECTRIC PANEL	(3) HYDRAULIC STD - A304 KIT	(3) HYDRAULIC A316 KIT	(4) MEMBRANE TANK STD KIT	(4) MEMBRANE TANK A304 KIT
1SVH15..007	0,75	1x230 V	1086060000	109422113	109422125	109391560	109391561
		3x400 V	1086061500	109422113	109422125	109391560	-
1SVH22..011	1,1	1x230 V	1086060000	109422113	109422125	109391570	-
		3x400 V	1086061500	109422113	109422125	109391570	-
1SVH30..015	1,5	1x230 V	1086060000	109422113	109422125	109395050	-
		3x400 V	1086061500	109422113	109422125	109395050	-
1SVH37..022	2,2	1x230 V	1086060100	109422113	109422125	109395050	-
		3x400 V	1086061600	109422113	109422125	109395050	-
3SVH08..007	0,75	1x230 V	1086060000	109422113	109422125	109391560	109391561
		3x400 V	1086061500	109422113	109422125	109391560	109391561
3SVH12..011	1,1	1x230 V	1086060000	109422113	109422125	109391560	109391561
		3x400 V	1086061500	109422113	109422125	109391560	109391561
3SVH16..015	1,5	1x230 V	1086060000	109422113	109422125	109391570	-
		3x400 V	1086061500	109422113	109422125	109391570	-
3SVH21..022	2,2	1x230 V	1086060100	109422113	109422125	109391570	-
		3x400 V	1086061600	109422113	109422125	109391570	-
3SVH25..022	2,2	1x230 V	1086060100	109422113	109422125	109395050	-
		3x400 V	1086061600	109422113	109422125	109395050	-
3SVH29..030	3	1x230 V	1086060200	109422113	109422125	109395050	-
		3x400 V	1086061700	109422113	109422125	109395050	-
5SVH05..007	0,75	1x230 V	1086060000	109422114	109422126	109391560	109391561
		3x400 V	1086061500	109422114	109422126	109391560	109391561
5SVH08..011	1,1	1x230 V	1086060000	109422114	109422126	109391560	109391561
		3x400 V	1086061500	109422114	109422126	109391560	109391561
5SVH11..015	1,5	1x230 V	1086060000	109422114	109422126	109391560	109391561
		3x400 V	1086061500	109422114	109422126	109391560	109391561
5SVH14..022	2,2	1x230 V	1086060100	109422114	109422126	109391570	-
		3x400 V	1086061600	109422114	109422126	109391570	-
5SVH16..022	2,2	1x230 V	1086060100	109422114	109422126	109391570	-
		3x400 V	1086061600	109422114	109422126	109391570	-
5SVH21..030	3	1x230 V	1086060200	109422114	109422126	109391570	-
		3x400 V	1086061700	109422114	109422126	109391570	-
5SVH28..040	4	1x230 V	1086060300	109422114	109422126	109395050	-
		3x400 V	1086061800	109422114	109422126	109395050	-
5SVH33..055	5,5	3x400 V	1086061900	109422114	109422126	109395050	-

**G/SVH KIT
TABLE OF COMPONENTS**

(1) PUMP TYPE	KW	VOLTAGE	(2) ELECTRIC PANEL	(3) HYDRAULIC STD- A304 KIT	(3) HYDRAULIC A316 KIT	(4) MEMBRANE TANK STD KIT	(4) MEMBRANE TANK A304 KIT
10SVH04..015	1,5	1x230 V	1086060000	109422115	109422127	109391560	109391561
		3x400 V	1086061500	109422115	109422127	109391560	109391561
10SVH06..022	2,2	1x230 V	1086060100	109422115	109422127	109391560	109391561
		3x400 V	1086061600	109422115	109422127	109391560	109391561
10SVH08..030	3	1x230 V	1086060200	109422115	109422127	109391560	109391561
		3x400 V	1086061700	109422115	109422127	109391560	109391561
10SVH11..040	4	1x230 V	1086060300	109422115	109422127	109391570	-
		3x400 V	1086061800	109422115	109422127	109391570	-
10SVH15..055	5,5	3x400 V	1086061900	109422115	109422127	109395050	-
10SVH20..075	7,5	3x400 V	108212500	109422115	109422127	109395050	-
10SVH21..110	11	3x400 V	108212600	109422115	109422127	109395050	-
15SVH02..022	2,2	1x230 V	1086060100	109422116	109422128	109391560	109391561
		3x400 V	1086061600	109422116	109422128	109391560	109391561
15SVH03..030	3	1x230 V	1086060200	109422116	109422128	109391560	109391561
		3x400 V	1086061700	109422116	109422128	109391560	109391561
15SVH05..040	4	1x230 V	1086060300	109422116	109422128	109391560	109391561
		3x400 V	1086061800	109422116	109422128	109391560	109391561
15SVH07..055	5,5	3x400 V	1086061900	109422116	109422128	109391570	-
15SVH09..075	7,5	3x400 V	1086062000	109422116	109422128	109391570	-
15SVH13..110	11	3x400 V	1086062100	109422116	109422128	109395050	-
15SVH17..150	15	3x400 V	1086062200	109422116	109422128	109395050	-
22SVH01..011	1,1	1x230 V	1086060000	109422116	109422128	109391560	109391561
		3x400 V	1086061500	109422116	109422128	109391560	109391561
22SVH03..030	3	1x230 V	1086060200	109422116	109422128	109391560	109391561
		3x400 V	1086061700	109422116	109422128	109391560	109391561
22SVH04..040	4	1x230 V	1086060300	109422116	109422128	109391560	109391561
		3x400 V	1086061800	109422116	109422128	109391560	109391561
22SVH05..055	5,5	3x400 V	1086061900	109422116	109422128	109391560	109391561
22SVH07..075	7,5	3x400 V	1086062000	109422116	109422128	109391570	-
22SVH10..110	11	3x400 V	1086062100	109422116	109422128	109391570	-
22SVH14..150	15	3x400 V	1086062200	109422116	109422128	109395050	-
33SVH1/1A..022	2,2	1x230 V	1086060100	109422117	109422129	109391560	109391561
		3x400 V	1086061600	109422117	109422129	109391560	109391561
33SVH1..030	3	1x230 V	1086060200	109422117	109422129	109391560	109391561
		3x400 V	1086061700	109422117	109422129	109391560	109391561
33SVH2..055	5,5	3x400 V	1086061900	109422117	109422129	109391560	109391561
33SVH3..075	7,5	3x400 V	1086062000	109422117	109422129	109391560	109391561
33SVH4..110	11	3x400 V	1086062100	109422117	109422129	109391570	-
33SVH5..150	15	3x400 V	1086062200	109422117	109422129	109391570	-
33SVH6..150	15	3x400 V	1086062200	109422118	109422130	109391570	-
33SVH7..185	18,5	3x400 V	1086062300	109422118	109422130	109395050	-
46SVH1..040	4	1x230 V	1086060300	109422119	109422131	109391560	109391561
		3x400 V	1086061800	109422119	109422131	109391560	109391561
46SVH2..075	7,5	3x400 V	1086062000	109422119	109422131	109391560	109391561
46SVH3..110	11	3x400 V	1086062100	109422119	109422131	109391560	109391561
46SVH4..150	15	3x400 V	1086062200	109422119	109422131	109391570	-
46SVH6..220	22	3x400 V	1086062400	109422120	109422132	109391570	-
66SVH1..055	5,5	3x400 V	1086061900	109422121	109422133	109391560	109391561
66SVH2..110	11	3x400 V	1086062100	109422121	109422133	109391560	109391561
66SVH3..185	18,5	3x400 V	1086062300	109422121	109422133	109391570	-
66SVH4..220	22	3x400 V	1086062400	109422121	109422133	109391570	-
92SVH1..075	7,5	3x400 V	1086062000	109422121	109422133	109391560	109391561
92SVH2..150	15	3x400 V	1086062200	109422121	109422133	109391560	109391561
92SVH3..220	22	3x400 V	1086062400	109422121	109422133	109391570	-
125SVH1..075	7,5	3x400 V	1086062000	109422123	109422135	109391560	109391561
125SVH2..150	15	3x400 V	1086062200	109422123	109422135	109391560	109391561
125SVH3..220	22	3x400 V	1086062400	109422123	109422135	109391560	109391561

PROTECTION SENSOR AGAINST DRY RUNNING



Sensor for detecting the presence of water based on the optoelectronic principle, therefore non-invasive and with no moving parts. The sensor features an electronic contact (on/off) which stops the pump if there is no water in the seal area.

The sensor opens the electric contact if there is no water after they factory-set delay (10 seconds) elapses. The sensor is supplied as a kit complete with 2 metres of cable, an EPDM O-ring gasket and a stainless steel adapter.

General operating featuresgo

- **SENSOR KIT DRP-GP: 21 ÷ 27 Vca:** In the boosters sets the sensor is assembled on the suction manifold with a specific hydraulic fitting.
21 ÷ 27 Vca version, universal solid state output for external relay at 24 Vac (21 ÷ 27 Vac, 50 mA).
- **KIT SENSOR DRP-HV: 15 ÷ 25 Vcc:** The sensor can also be fitted directly on the filling cap of the e-SV pumps series.
15 ÷ 25 Vcc version, NPN output at 25 V (10 mA) for HYDROVAR inverter and e-SM drive.
- Operation is independent of the hardness and conductivity of the water. The sensor cannot detect frozen liquids.

Operating principle

Operation is based on the change in the refractive index on the surfaces. The optic sensor comprises a glass cap (C) containing a transmitter (T) and an infrared receiver (R).

If there is no liquid, all the infrared light emitted by the transmitter is internally reflected by the surface of the glass cap of the receiver. The electronic contact will be open.

If liquid is present, the refractive index of the surface changes. Most of the infrared light emitted by the transmitter is dispersed in the liquid. The receiver receives less light and the electronic contact is closed.

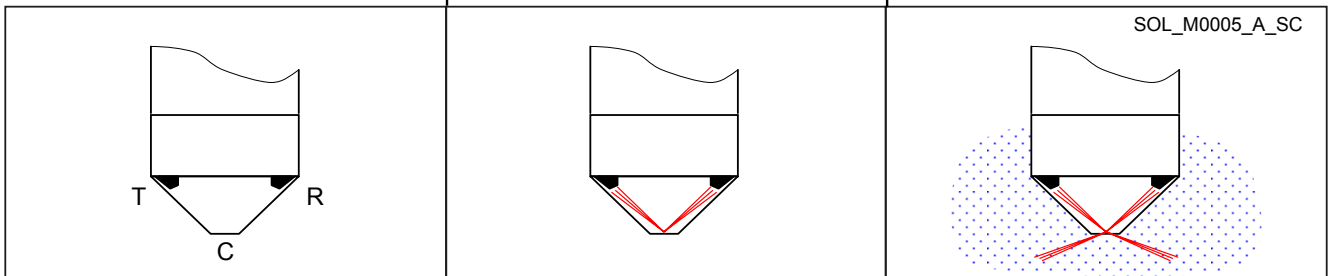

SPECIFICATIONS

- Materials:
 - Body in AISI 316L stainless steel
 - Glass optic cap
 - EPDM gasket
- Liquids: clean water, demi water. Operation is not affected by the hardness and conductivity of the liquid. To check the suitability of other liquids, contact the Lowara technical assistance service providing the characteristics of the liquid.
- Temperature of liquid: -20°C ÷ +120°C (cannot be used to detect frozen liquids).
- Ambient temperature: -5°C ÷ +50°C
- Maximum pressure (PN): 25 bar
- Connector: 3/8" (3/8" x 1/2" adaptor plug included in the Kit)
- Dimensions: 27x 60 mm
- IP55 protection
- Electrical characteristics:
 - Input voltage SENSOR KIT DRP-GP: 21 ÷ 27 Vac
SENSOR KIT DRP-HV: 15 ÷ 25 Vdc
 - Output SENSOR KIT DRP-GP: universal solid state 21 ÷ 27 Vac (50 mA) for 24 Vac external relay
SENSOR KIT DRP-HV: NPN 25 V (10 mA) for HYDROVAR inverter
 - Alarm delay: 10 seconds (factory setting)
 - FROR cable 4 x 0,34 mm² (PVC-CEI 20-22) 2 metres long.

WIRING DIAGRAM

SENSOR KIT DRP-GP (code 109394610)

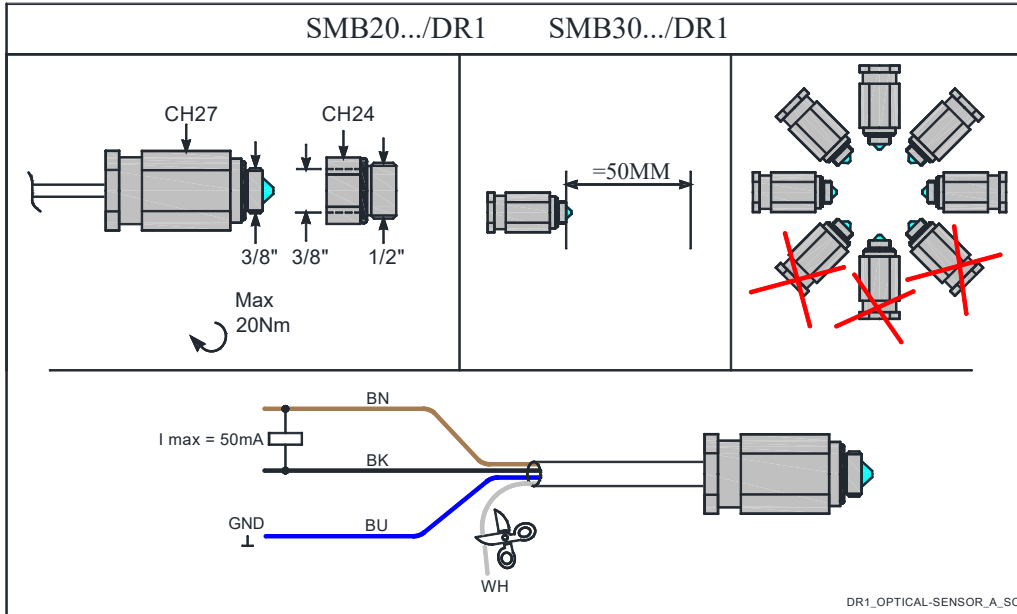

SENSOR KIT DRP-HV (code 109394600)

The sensor can be directly mounted on the filling plug of the e-SV pumps.
 For the 33, 46, 66, 92, 125SV series, the 3/8" x 1/2" adaptor ring included in the Kit must also be mounted.

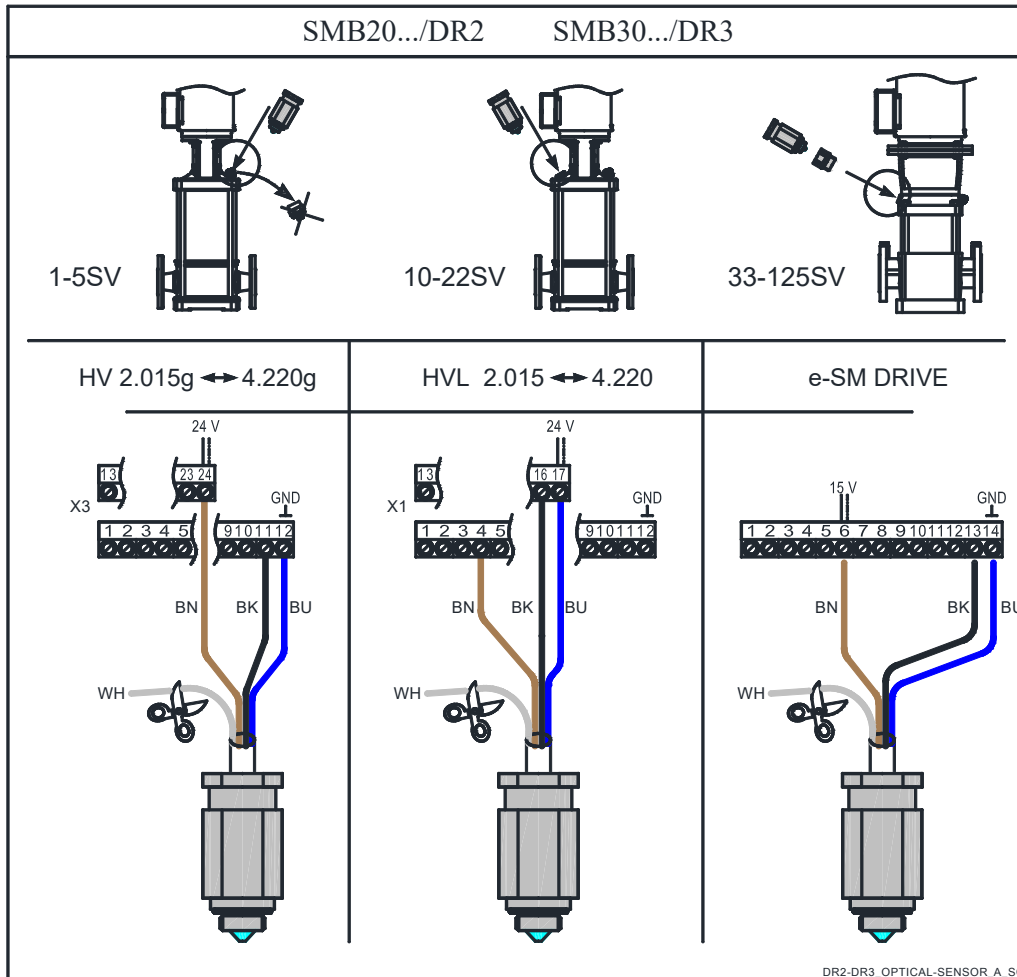

DIMENSIONS OF OVAL COUNTERFLANGES (SV T)

PUMP TYPE	DN	ø C	DIMENSIONS (mm)				HOLES		TIGHTENING TORQUE (Nm)	PN
			A	B	D	H	ø F	N°		
1-3SVT	25	Rp 1	75	12	100	22	11	2	40	16
5SVT	32	Rp 1¼	75	12	100	22	11	2	40	16
10SVT	40	Rp 1½	100	15	132	25	14	2	60	16
15-22SVT	50	Rp 2	100	15	132	25	14	2	60	16

1-22sv-ctf-ovali-en_b_td

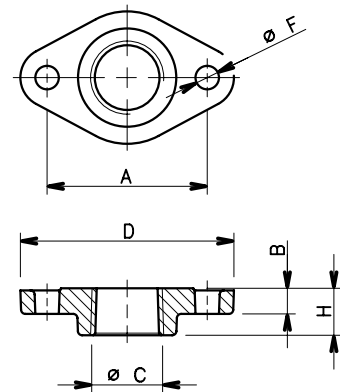

04429_B_DD

Standard supply (included with the pump)

- AISI 304L stainless steel (T versions).

DIMENSIONS OF ROUND THREADED COUNTERFLANGES (SV F, N, R, G) ACCORDING TO EN 1092-1

PUMP TYPE	DN	ø C	DIMENSIONS (mm)				HOLES		TIGHTENING TORQUE (Nm)	PN
			ø A	B	ø D	H	ø F	N°		
1-3SV	25	Rp 1	85	10	115	16	14	4	50	25
5SV	32	Rp 1¼	100	13	140	16	18	4	100	25
10SV	40	Rp 1½	110	14	150	19	18	4	100	25
15-22SV	50	Rp 2	125	16	165	24	18	4	100	25
33SV	65	Rp 2½	145	16	185	23	18	4	100	16
46SV	80	Rp 3	160	17	200	27	18	8	100	16
66SV-92SV	100	Rp 4	180	18	220	31	18	8	100	16

1-92sv-ctf-tonde-f-en_b_td

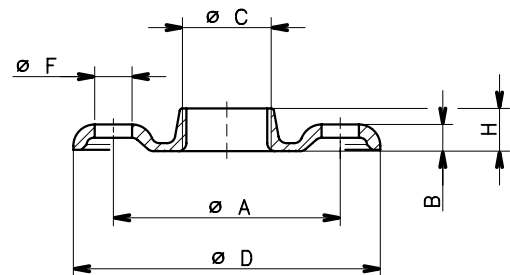

04430_B_DD

Round counterflanges Kit available on request:

Kit containing 2 counterflanges with bolts and gaskets.

- threaded, galvanized steel (F, R, G versions).
- threaded, AISI 316L stainless steel (N versions).

DIMENSIONS OF WELD-ON ROUND COUNTERFLANGES (SV G, N) ACCORDING TO EN 1092-1

PUMP TYPE	DN	ø C	DIMENSIONS (mm)				HOLES		TIGHTENING TORQUE (Nm)	PN
			ø A	B	ø D	ø F	N°			
33SV	65	77,5	145	20	185	18	4	100	16	
46SV	80	90,5	160	20	200	18	8	100	16	
66SV-92SV	100	116	180	22	220	18	8	100	16	
125SV	125	141,5	210	22	250	18	8	100	16	
33SV	65	77,5	145	22	185	18	8	200	25-40	
46SV	80	90,5	160	24	200	18	8	200	25-40	
66SV-92SV	100	116	190	26	235	22	8	200	25-40	
125SV	125	141,5	220	28	270	26	8	200	25-40	

33-125sv-ctf-tonde-s-en_b_td

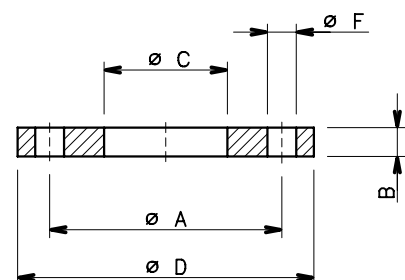

04431_A_DD

Round counterflanges Kit available on request:

Kit containing 2 counterflanges with bolts and gaskets.

- weld-on counterflanges, galvanized steel (G versions).
- weld-on counterflanges, AISI 316L stainless steel (N versions).

DIMENSIONS OF VICTAULIC® COUPLINGS (SV V)

Victaulic® couplings kit available on request:

Galvanized steel Victaulic® coupling with AISI 316L stainless steel weld-on or threaded sleeve, plus EPDM or FPM gasket. Kits are available for the single version (1 coupling) or double version (2 couplings).

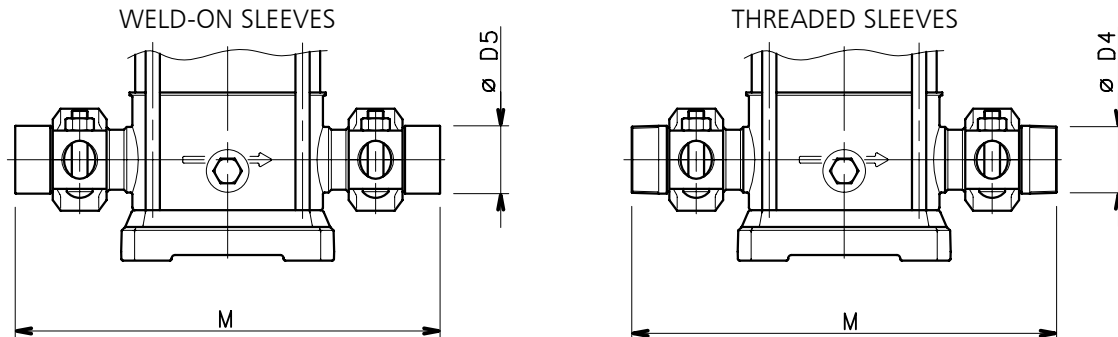

P.NUMBER	DESCRIPTION	PUMP TYPE	DN	DIMENSIONS (mm)		
				ø D	M	H
109390880	KIT SINGLE VICTAULIC THREADED R 1"1/4 EPDM	1-3-5SV V	DN32	R 1"1/4	320	75
109390980	KIT SINGLE VICTAULIC THREADED R 1"1/4 FPM	1-3-5SV V	DN32	R 1"1/4	320	75
109390890	KIT SINGLE VICTAULIC THREADED R 2" EPDM	10-15-22SV V	DN50	R 2"	378	90
109390990	KIT SINGLE VICTAULIC THREADED R 2" FPM	10-15-22SV V	DN50	R 2"	378	90
109390860	KIT SINGLE VICTAULIC DN32 WELD-ON EPDM	1-3-5SV V	DN32	42,2	320	75
109390960	KIT SINGLE VICTAULIC DN32 WELD-ON FPM	1-3-5SV V	DN32	42,2	320	75
109390870	KIT SINGLE VICTAULIC DN50 WELD-ON EPDM	10-15-22SV V	DN50	60,3	378	90
109390970	KIT SINGLE VICTAULIC DN50 WELD-ON FPM	10-15-22SV V	DN50	60,3	378	90
109398400	KIT DOUBLE VICTAULIC THREADED R 1"1/4 EPDM	1-3-5SV V	DN32	R 1"1/4	320	75
109398401	KIT DOUBLE VICTAULIC THREADED R 1"1/4 FPM	1-3-5SV V	DN32	R 1"1/4	320	75
109398410	KIT DOUBLE VICTAULIC THREADED R 2" EPDM	10-15-22SV V	DN50	R 2"	378	90
109398411	KIT DOUBLE VICTAULIC THREADED R 2" FPM	10-15-22SV V	DN50	R 2"	378	90
109398420	KIT DOUBLE VICTAULIC DN32 WELD-ON EPDM	1-3-5SV V	DN32	42,2	320	75
109398421	KIT DOUBLE VICTAULIC DN32 WELD-ON FPM	1-3-5SV V	DN32	42,2	320	75
109398430	KIT DOUBLE VICTAULIC DN50 WELD-ON EPDM	10-15-22SV V	DN50	60,3	378	90
109398431	KIT DOUBLE VICTAULIC DN50 WELD-ON FPM	10-15-22SV V	DN50	60,3	378	90

1-22sv-giunti-vict-en_b_td

04427_B_DD

DIMENSIONS OF CLAMP COUPLINGS (SV C)

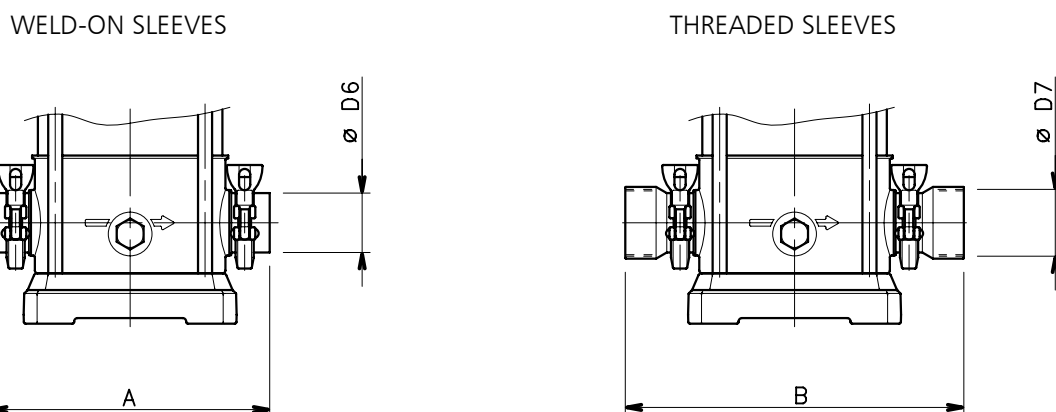

PUMP TYPE	DIMENSIONS (mm)			
	A	B	ø D6	ø D7
1-3-5SV C	208	245	35	Rp 1¼
10-15-22SV C	248	301	53	Rp 2

1-22sv-giunti-clamp-en_a_td

Clamp couplings kit available on request:

Kit containing 2 Clamp couplings with AISI 316L stainless steel weld-on or threaded sleeve, plus EPDM or FPM gasket. Coupling shape and dimensions according to DIN 32676.

04426_B_DD

SPECIAL VERSIONS NOT DESCRIBED IN THIS CATALOGUE

More and more customers require specific solutions for satisfying particular application requirements. To meet their needs, Lowara offers a series of variants for personalising the e-SV pumps.

For more information, please see [e-SV Special Versions catalogue](#).

- **High Pressure (50/60 Hz)**

- Water treatment industry - washing and cleaning
- Versatile range
 - Long lasting performances
 - Easy installation and maintenance

- **Low NPSH (50/60 Hz)**

- Solving cavitation issues in installation
- Consistent operation
 - Long lasting performances
 - Easy installation

- **High Temperature (50/60 Hz)**

- Electric pumps for high temperature applications
- **H** versions for temperature values up to 150°C
 - **B** "BOILER" versions for temperature values up to 180°C

- **4-POLE Version (50/60 Hz)**

- Silencious operation
- Low level of noise
 - Wide range of performances
 - Increased performance with HYDROVAR (50 Hz)

- **Reduced overall dimensions (50/60 Hz)**

- Space saving in installation
- Compact design
 - Versatile design
 - High level performances

- **Horizontal Installation (50/60 Hz)**

- Installation in reduced vertical space
- Reduced vertical space
 - Easy installation

- **Accessories**

Wide range of accessories for installation

Furthermore:

- **Passivated and electro-polished version**

All e-SV pump components are passivated and electro-polished in order to reduce the risk of corrosion and to comply with specific hygiene requirements.

- **Version with stainless steel base**

The e-SV pump can be supplied with a stainless steel base for applications in aggressive conditions.

- **Version with pump body in stainless steel**

1.4408 (AISI 316 cast) for series 1, 3, 5, 10, 15, 22SV.

CUSTOMIZED VERSION

For further customization please contact the sales network.

REPORTS AND DECLARATIONS

REPORTS AND DECLARATIONS

i) Test reports

- a) **Factory Test Report** (Lowara identity code: 1A)
(not available for all pump types; contact Customer Service in advance)
- Test report compiled at the end of the assembly line, including flow-head performance test (ISO 9906:2012 – Grade 3B) and tightness test.
- b) **Audit Test Report** (Lowara identity code: 1B)
- Test report for electric pumps compiled in the test room, comprising flow-head-pump input-pump efficiency performance test (ISO 9906:2012 – Grade 3B)
- c) **NPSH Test Report** (Lowara identity code: 1B / CTF-NP)
(unavailable for submerged or submergible pumps)
- Test report for electric pumps compiled in the test room, comprising flow-NPSH performance test (ISO 9906:2012 – Grade 3B)
- d) **Noise Test Report** (Lowara identity code: 1B / CTF-RM)
(unavailable for submerged pumps)
- Report indicating sound pressure and power measurements (EN ISO 20361, EN ISO 11203, EN ISO 4871) using the
• intensimetric (EN ISO 9614-1, EN ISO 9614-2), or
• phonometric method.
- e) **Vibration Test Report**
(unavailable for submerged or submergible pumps)
- Report indicating vibration measurements (ISO 10816-1)

ii) Declaration of product conformity with the technical requirements indicated in the order

- a) **EN 10204:2004 - type 2.1** (Lowara identity code: CTF-21)
- does not include test results on supplied or similar products.
- b) **EN 10204:2004 - type 2.2** (Lowara identity code: CTF-22)
- includes test results (materials certificates) on similar products.

iii) Issue of a further EC Declaration of Conformity,

- in addition to the one accompanying the product, it comprises references to European law and the main technical standards (e.g.: MD 2006/42/EC, EMCD 2004/108/EC, ErP 2009/125/EC).

N.B.: if the request is made after receipt of the product, communicate the code (name) and serial number (date + progressive number).

iv) Manufacturer's declaration of conformity

- relative to one of more types of products without indicating specific codes and serial numbers.

v) Other certificates and/or documentation on request

- subject to availability or feasibility.

vi) Duplication of certificates and/or documentation on request

- subject to availability or feasibility.

TECHNICAL APPENDIX

NPSH

The minimum operating values that can be reached at the pump suction end are limited by the onset of cavitation.

Cavitation is the formation of vapour-filled cavities within liquids where the pressure is locally reduced to a critical value, or where the local pressure is equal to, or just below the vapour pressure of the liquid.

The vapour-filled cavities flow with the current and when they reach a higher pressure area the vapour contained in the cavities condenses. The cavities collide, generating pressure waves that are transmitted to the walls. These, being subjected to stress cycles, gradually become deformed and yield due to fatigue. This phenomenon, characterized by a metallic noise produced by the hammering on the pipe walls, is called incipient cavitation.

The damage caused by cavitation may be magnified by electrochemical corrosion and a local rise in temperature due to the plastic deformation of the walls. The materials that offer the highest resistance to heat and corrosion are alloy steels, especially austenitic steel. The conditions that trigger cavitation may be assessed by calculating the total net suction head, referred to in technical literature with the acronym NPSH (Net Positive Suction Head).

The NPSH represents the total energy (expressed in m.) of the liquid measured at suction under conditions of incipient cavitation, excluding the vapour pressure (expressed in m.) that the liquid has at the pump inlet.

To find the static height h_z at which to install the machine under safe conditions, the following formula must be verified:

$$h_p + h_z \geq (NPSH_r + 0.5) + h_f + h_{pv} \quad \textcircled{1}$$

where:

- h_p** is the absolute pressure applied to the free liquid surface in the suction tank, expressed in m. of liquid; h_p is the quotient between the barometric pressure and the specific weight of the liquid.
- h_z** is the suction lift between the pump axis and the free liquid surface in the suction tank, expressed in m.; h_z is negative when the liquid level is lower than the pump axis.
- h_f** is the flow resistance in the suction line and its accessories, such as: fittings, foot valve, gate valve, elbows, etc.
- h_{pv}** is the vapour pressure of the liquid at the operating temperature, expressed in m. of liquid. h_{pv} is the quotient between the P_v vapour pressure and the liquid's specific weight.
- 0,5** is the safety factor.

The maximum possible suction head for installation depends on the value of the atmospheric pressure (i.e. the elevation above sea level at which the pump is installed) and the temperature of the liquid.

To help the user, with reference to water temperature (4° C) and to the elevation above sea level, the following tables show the drop in hydraulic pressure head in relation to the elevation above sea level, and the suction loss in relation to temperature.

Water temperature (°C)	20	40	60	80	90	110	120
Suction loss (m)	0,2	0,7	2,0	5,0	7,4	15,4	21,5

Elevation above sea level (m)	500	1000	1500	2000	2500	3000
Suction loss (m)	0,55	1,1	1,65	2,2	2,75	3,3

Friction loss is shown in the tables of this catalogue. To reduce it to a minimum, especially in cases of high suction head (over 4-5 m.) or within the operating limits with high flow rates, we recommend using a suction line having a larger diameter than that of the pump's suction port. It is always a good idea to position the pump as close as possible to the liquid to be pumped.

Make the following calculation:

Liquid: water at ~15°C $\gamma = 1 \text{ kg/dm}^3$
 Flow rate required: 25 m³/h
 Head for required delivery: 70 m.
 Suction lift: 3,5 m.
 The selection is an 33SV3G075T pump whose NPSH required value is, at 25 m³/h, of 2 m.

For water at 15 °C

$$h_p = P_a / \gamma = 10,33\text{m}, h_{pv} = P_v / \gamma = 0,174\text{m} (0,01701 \text{ bar})$$

The H_f flow resistance in the suction line with foot valves is ~ 1,2 m.

By substituting the parameters in formula $\textcircled{1}$ with the numeric values above, we have:

$$10,33 + (-3,5) \geq (2 + 0,5) + 1,2 + 0,17$$

from which we have: 6,8 > 3,9

The relation is therefore verified.

VAPOUR PRESSURE

VAPOUR PRESSURE p_s AND ρ DENSITY OF WATER TABLE

t °C	T K	p_s bar	ρ kg/dm ³	t °C	T K	p_s bar	ρ kg/dm ³	t °C	T K	p_s bar	ρ kg/dm ³
0	273,15	0,00611	0,9998	55	328,15	0,15741	0,9857	120	393,15	1,9854	0,9429
1	274,15	0,00657	0,9999	56	329,15	0,16511	0,9852	122	395,15	2,1145	0,9412
2	275,15	0,00706	0,9999	57	330,15	0,17313	0,9846	124	397,15	2,2504	0,9396
3	276,15	0,00758	0,9999	58	331,15	0,18147	0,9842	126	399,15	2,3933	0,9379
4	277,15	0,00813	1,0000	59	332,15	0,19016	0,9837	128	401,15	2,5435	0,9362
5	278,15	0,00872	1,0000	60	333,15	0,1992	0,9832	130	403,15	2,7013	0,9346
6	279,15	0,00935	1,0000	61	334,15	0,2086	0,9826	132	405,15	2,867	0,9328
7	280,15	0,01001	0,9999	62	335,15	0,2184	0,9821	134	407,15	3,041	0,9311
8	281,15	0,01072	0,9999	63	336,15	0,2286	0,9816	136	409,15	3,223	0,9294
9	282,15	0,01147	0,9998	64	337,15	0,2391	0,9811	138	411,15	3,414	0,9276
10	283,15	0,01227	0,9997	65	338,15	0,2501	0,9805	140	413,15	3,614	0,9258
11	284,15	0,01312	0,9997	66	339,15	0,2615	0,9799	145	418,15	4,155	0,9214
12	285,15	0,01401	0,9996	67	340,15	0,2733	0,9793	155	428,15	5,433	0,9121
13	286,15	0,01497	0,9994	68	341,15	0,2856	0,9788	160	433,15	6,181	0,9073
14	287,15	0,01597	0,9993	69	342,15	0,2984	0,9782	165	438,15	7,008	0,9024
15	288,15	0,01704	0,9992	70	343,15	0,3116	0,9777	170	443,15	7,920	0,8973
16	289,15	0,01817	0,9990	71	344,15	0,3253	0,9770	175	448,15	8,924	0,8921
17	290,15	0,01936	0,9988	72	345,15	0,3396	0,9765	180	453,15	10,027	0,8869
18	291,15	0,02062	0,9987	73	346,15	0,3543	0,9760	185	458,15	11,233	0,8815
19	292,15	0,02196	0,9985	74	347,15	0,3696	0,9753	190	463,15	12,551	0,8760
20	293,15	0,02337	0,9983	75	348,15	0,3855	0,9748	195	468,15	13,987	0,8704
21	294,15	0,24850	0,9981	76	349,15	0,4019	0,9741	200	473,15	15,550	0,8647
22	295,15	0,02642	0,9978	77	350,15	0,4189	0,9735	205	478,15	17,243	0,8588
23	296,15	0,02808	0,9976	78	351,15	0,4365	0,9729	210	483,15	19,077	0,8528
24	297,15	0,02982	0,9974	79	352,15	0,4547	0,9723	215	488,15	21,060	0,8467
25	298,15	0,03166	0,9971	80	353,15	0,4736	0,9716	220	493,15	23,198	0,8403
26	299,15	0,03360	0,9968	81	354,15	0,4931	0,9710	225	498,15	25,501	0,8339
27	300,15	0,03564	0,9966	82	355,15	0,5133	0,9704	230	503,15	27,976	0,8273
28	301,15	0,03778	0,9963	83	356,15	0,5342	0,9697	235	508,15	30,632	0,8205
29	302,15	0,04004	0,9960	84	357,15	0,5557	0,9691	240	513,15	33,478	0,8136
30	303,15	0,04241	0,9957	85	358,15	0,5780	0,9684	245	518,15	36,523	0,8065
31	304,15	0,04491	0,9954	86	359,15	0,6011	0,9678	250	523,15	39,776	0,7992
32	305,15	0,04753	0,9951	87	360,15	0,6249	0,9671	255	528,15	43,246	0,7916
33	306,15	0,05029	0,9947	88	361,15	0,6495	0,9665	260	533,15	46,943	0,7839
34	307,15	0,05318	0,9944	89	362,15	0,6749	0,9658	265	538,15	50,877	0,7759
35	308,15	0,05622	0,9940	90	363,15	0,7011	0,9652	270	543,15	55,058	0,7678
36	309,15	0,05940	0,9937	91	364,15	0,7281	0,9644	275	548,15	59,496	0,7593
37	310,15	0,06274	0,9933	92	365,15	0,7561	0,9638	280	553,15	64,202	0,7505
38	311,15	0,06624	0,9930	93	366,15	0,7849	0,9630	285	558,15	69,186	0,7415
39	312,15	0,06991	0,9927	94	367,15	0,8146	0,9624	290	563,15	74,461	0,7321
40	313,15	0,07375	0,9923	95	368,15	0,8453	0,9616	295	568,15	80,037	0,7223
41	314,15	0,07777	0,9919	96	369,15	0,8769	0,9610	300	573,15	85,927	0,7122
42	315,15	0,08198	0,9915	97	370,15	0,9094	0,9602	305	578,15	92,144	0,7017
43	316,15	0,09639	0,9911	98	371,15	0,9430	0,9596	310	583,15	98,70	0,6906
44	317,15	0,09100	0,9907	99	372,15	0,9776	0,9586	315	588,15	105,61	0,6791
45	318,15	0,09582	0,9902	100	373,15	1,0133	0,9581	320	593,15	112,89	0,6669
46	319,15	0,10086	0,9898	102	375,15	1,0878	0,9567	325	598,15	120,56	0,6541
47	320,15	0,10612	0,9894	104	377,15	1,1668	0,9552	330	603,15	128,63	0,6404
48	321,15	0,11162	0,9889	106	379,15	1,2504	0,9537	340	613,15	146,05	0,6102
49	322,15	0,11736	0,9884	108	381,15	1,3390	0,9522	350	623,15	165,35	0,5743
50	323,15	0,12335	0,9880	110	383,15	1,4327	0,9507	360	633,15	186,75	0,5275
51	324,15	0,12961	0,9876	112	385,15	1,5316	0,9491	370	643,15	210,54	0,4518
52	325,15	0,13613	0,9871	114	387,15	1,6362	0,9476	374,15	647,30	221,20	0,3154
53	326,15	0,14293	0,9862	116	389,15	1,7465	0,9460				
54	327,15	0,15002	0,9862	118	391,15	1,8628	0,9445				

G-at_npsb_sc

TABLE OF FLOW RESISTANCE IN 100 m OF STRAIGHT CAST IRON PIPELINE (HAZEN-WILLIAMS FORMULA C=100)

FLOW RATE		NOMINAL DIAMETER in mm and inches																		
m ³ /h	l/min	15	20	25	32	40	50	65	80	100	125	150	175	200	250	300	350	400		
		1/2"	3/4"	1"	1 1/4"	1 1/2"	2	2 1/2"	3"	4"	5"	6"	7"	8"	10"	12"	14"	16"		
0,6	10	v hr	0,94 16	0,53 3,94	0,34 1,33	0,21 0,40	0,13 0,13													
0,9	15	v hr	1,42 33,9	0,80 8,35	0,51 2,82	0,31 0,85	0,20 0,29													
1,2	20	v hr	1,89 57,7	1,06 14,21	0,68 4,79	0,41 1,44	0,27 0,49	0,17 0,16												
1,5	25	v hr	2,36 87,2	1,33 21,5	0,85 7,24	0,52 2,18	0,33 0,73	0,21 0,25												
1,8	30	v hr	2,83 122	1,59 30,1	1,02 10,1	0,62 3,05	0,40 1,03	0,25 0,35												
2,1	35	v hr	3,30 162	1,86 40,0	1,19 13,5	0,73 4,06	0,46 1,37	0,30 0,46												
2,4	40	v hr		2,12 51,2	1,36 17,3	0,83 5,19	0,53 1,75	0,34 0,59	0,20 0,16											
3	50	v hr		2,65 77,4	1,70 26,1	1,04 7,85	0,66 2,65	0,42 0,89	0,25 0,25											
3,6	60	v hr		3,18 108	2,04 36,6	1,24 11,0	0,80 3,71	0,51 1,25	0,30 0,35											
4,2	70	v hr		3,72 144	2,38 48,7	1,45 14,6	0,93 4,93	0,59 1,66	0,35 0,46											
4,8	80	v hr		4,25 185	2,72 62,3	1,66 18,7	1,06 6,32	0,68 2,13	0,40 0,59											
5,4	90	v hr			3,06 77,5	1,87 23,3	1,19 7,85	0,76 2,65	0,45 0,74	0,30 0,27										
6	100	v hr			3,40 94,1	2,07 28,3	1,33 9,54	0,85 3,22	0,50 0,90	0,33 0,33										
7,5	125	v hr			4,25 142	2,59 42,8	1,66 14,4	1,06 4,86	0,63 1,36	0,41 0,49										
9	150	v hr				3,11 59,9	1,99 20,2	1,27 6,82	0,75 1,90	0,50 0,69	0,32 0,23									
10,5	175	v hr				3,63 79,7	2,32 26,9	1,49 9,07	0,88 2,53	0,58 0,92	0,37 0,31									
12	200	v hr				4,15 102	2,65 34,4	1,70 11,6	1,01 3,23	0,66 1,18	0,42 0,40									
15	250	v hr				5,18 154	3,32 17,5	2,12 4,89	1,26 4,89	0,83 1,78	0,53 0,60	0,34 0,20								
18	300	v hr				3,98 72,8	2,55 24,6	1,51 6,85	1,00 2,49	0,64 0,84	0,41 0,28									
24	400	v hr				5,31 124	3,40 41,8	2,01 11,66	1,33 4,24	0,85 1,43	0,54 0,48	0,38 0,20								
30	500	v hr				6,63 187	4,25 63,2	2,51 17,6	1,66 6,41	1,06 2,16	0,68 0,73	0,47 0,30								
36	600	v hr				5,10 88,6	3,02 24,7	1,99 8,98	1,27 3,03	0,82 1,02	0,57 0,42	0,42 0,20								
42	700	v hr				5,94 118	3,52 32,8	2,32 11,9	1,49 4,03	0,95 1,36	0,66 0,56	0,49 0,26								
48	800	v hr				6,79 151	4,02 42,0	2,65 15,3	1,70 5,16	1,09 1,74	0,75 0,72	0,55 0,34								
54	900	v hr				7,64 188	4,52 52,3	2,99 19,0	1,91 6,41	1,22 2,16	0,85 0,89	0,62 0,42								
60	1000	v hr				5,03 63,5	3,32 23,1	2,12 7,79	1,36 2,63	1,06 1,08	0,73 0,51	0,53 0,27								
75	1250	v hr				6,28 96,0	4,15 34,9	2,65 11,8	1,70 3,97	1,18 1,63	0,87 0,77	0,66 0,40								
90	1500	v hr				7,54 134	4,98 48,9	3,18 16,5	2,04 5,57	1,42 2,29	1,04 1,08	0,80 0,56								
105	1750	v hr				8,79 179	5,81 65,1	3,72 21,9	2,38 7,40	1,65 3,05	1,21 1,44	0,93 0,75								
120	2000	v hr				6,63 83,3	4,25 28,1	2,72 9,48	1,89 3,90	1,39 1,84	1,06 0,96	0,68 0,32								
150	2500	v hr				8,29 126	5,31 42,5	3,40 14,3	2,36 5,89	1,73 2,78	1,33 1,45	0,85 0,49								
180	3000	v hr				6,37 59,5	4,08 20,1	2,83 8,26	2,08 3,90	1,59 2,03	1,02 0,69	0,71 0,28								
210	3500	v hr				7,43 79,1	4,76 26,7	3,30 11,0	2,43 5,18	1,86 2,71	1,19 0,91	0,83 0,38								
240	4000	v hr				8,49 101	5,44 34,2	3,77 14,1	2,77 6,64	2,12 3,46	1,36 1,17	0,94 0,48								
300	5000	v hr				6,79 51,6	4,72 21,2	3,47 10,0	2,65 5,23	1,70 1,77	1,18 0,73									
360	6000	v hr				8,15 72,3	5,66 29,8	4,16 14,1	3,18 7,33	2,04 2,47	1,42 1,02									
420	7000	v hr				6,61 39,6	4,85 18,7	3,72 9,75	2,38 3,29	1,65 1,35	1,21 0,64									
480	8000	v hr				7,55 50,7	5,55 23,9	4,25 12,49	2,72 4,21	1,89 1,73	1,39 0,82									
540	9000	v hr				8,49 63,0	6,24 29,8	4,78 15,5	3,06 5,24	2,12 2,16	1,56 1,02	1,19 0,53								
600	10000	v hr				6,93 36,2	5,31 18,9	3,40 6,36	2,36 2,62	1,73 1,24	1,33 0,65									

hr = flow resistance for 100 m of straight pipeline (m)

V = water speed (m/s)

G-at-pct-en_b_th

FLOW RESISTANCE

TABLE OF FLOW RESISTANCE IN BENDS, VALVES AND GATES

The flow resistance is calculated using the equivalent pipeline length method according to the table below:

ACCESSORY TYPE	DN											
	25	32	40	50	65	80	100	125	150	200	250	300
Equivalent pipeline length (m)												
45° bend	0,2	0,2	0,4	0,4	0,6	0,6	0,9	1,1	1,5	1,9	2,4	2,8
90° bend	0,4	0,6	0,9	1,1	1,3	1,5	2,1	2,6	3,0	3,9	4,7	5,8
90° smooth bend	0,4	0,4	0,4	0,6	0,9	1,1	1,3	1,7	1,9	2,8	3,4	3,9
Union tee or cross	1,1	1,3	1,7	2,1	2,6	3,2	4,3	5,3	6,4	7,5	10,7	12,8
Gate valve	-	-	-	0,2	0,2	0,2	0,4	0,4	0,6	0,9	1,1	1,3
Foot check valve	1,1	1,5	1,9	2,4	3,0	3,4	4,7	5,9	7,4	9,6	11,8	13,9
Non return valve	1,1	1,5	1,9	2,4	3,0	3,4	4,7	5,9	7,4	9,6	11,8	13,9

G-a-pcv-en_b_th

The table is valid for the Hazen Williams coefficient $C=100$ (cast iron pipework);

for steel pipework, multiply the values by 1,41;

for stainless steel, copper and coated cast iron pipework, multiply the values by 1,85;

When the **equivalent pipeline length** has been determined, the flow resistance is obtained from the table of flow resistance.

The values given are guideline values which are bound to vary slightly according to the model, especially for gate valves and non-return valves, for which it is a good idea to check the values supplied by manufacturers.

VOLUMETRIC CAPACITY

Litres per minute l/min	Cubic metres per hour m ³ /h	Cubic feet per hour ft ³ /h	Cubic feet per minute ft ³ /min	Imperial gallon per minute Imp. gal/min	U.S. gallon per minute US gal/min
1,000	0,0600	2,1189	0,0353	0,2200	0,2642
16,6667	1,0000	35,3147	0,5886	3,6662	4,4029
0,4719	0,0283	1,0000	0,0167	0,1038	0,1247
28,3168	1,6990	60,0000	1,0000	6,2288	7,4805
4,5461	0,2728	9,6326	0,1605	1,0000	1,2009
3,7854	0,2271	8,0208	0,1337	0,8327	1,0000

PRESSURE AND HEAD

Newton per square metre N/m ²	kilo Pascal kPa	bar bar	Pound force per square inch psi	Metre of water m H ₂ O	Millimetre of mercury mm Hg
1,0000	0,0010	1 x 10 ⁻⁵	1,45 x 10 ⁻⁴	1,02 x 10 ⁻⁴	0,0075
1 000,0000	1,0000	0,0100	0,1450	0,1020	7,5006
1 x 10 ⁵	100,0000	1,0000	14,5038	10,1972	750,0638
6 894,7570	6,8948	0,0689	1,0000	0,7031	51,7151
9 806,6500	9,8067	0,0981	1,4223	1,0000	73,5561
133,3220	0,1333	0,0013	0,0193	0,0136	1,0000

LENGTH

Millimetre mm	Centimetre cm	Metre m	Inch in	Foot ft	Yard yd
1,0000	0,1000	0,0010	0,0394	0,0033	0,0011
10,0000	1,0000	0,0100	0,3937	0,0328	0,0109
1 000,0000	100,0000	1,0000	39,3701	3,2808	1,0936
25,4000	2,5400	0,0254	1,0000	0,0833	0,0278
304,8000	30,4800	0,3048	12,0000	1,0000	0,3333
914,4000	91,4400	0,9144	36,0000	3,0000	1,0000

VOLUME

Cubic metre m ³	Litre L	Millilitre ml	Imperial gallon imp. gal.	U.S. gallon US gal.	Cubic foot ft ³
1,0000	1 000,0000	1 x 10 ⁶	219,9694	264,1720	35,3147
0,0010	1,0000	1 000,0000	0,2200	0,2642	0,0353
1 x 10 ⁻⁶	0,0010	1,0000	2,2 x 10 ⁻⁴	2,642 x 10 ⁻⁴	3,53 x 10 ⁻⁵
0,0045	4,5461	4 546,0870	1,0000	1,2009	0,1605
0,0038	3,7854	3 785,4120	0,8327	1,0000	0,1337
0,0283	28,3168	28 316,8466	6,2288	7,4805	1,0000

TEMPERATURE

Water	Kelvin K	Celsius °C	Fahrenheit °F	$^{\circ}\text{F} = ^{\circ}\text{C} \times \frac{9}{5} + 32$ $^{\circ}\text{C} = (^{\circ}\text{F} - 32) \times \frac{5}{9}$
icing	273,1500	0,0000	32,0000	
boiling	373,1500	100,0000	212,0000	

G-at_pp-en_b_sc

**FURTHER PRODUCT SELECTION
AND DOCUMENTATION**
Xylect

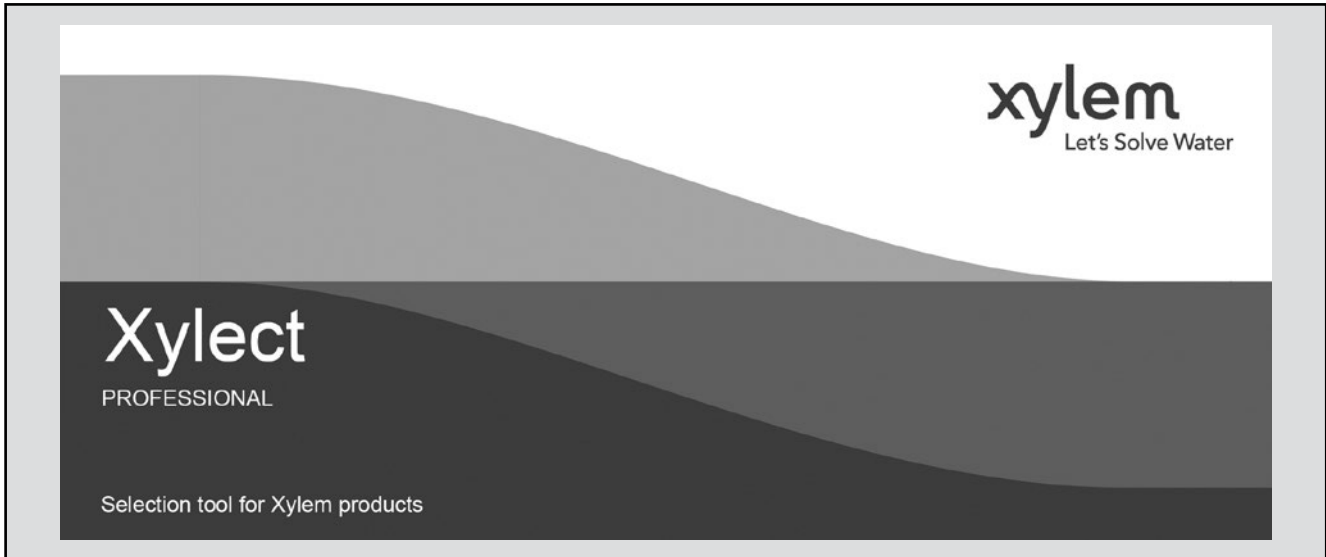

Xylect is pump solution selection software with an extensive online database of product information across the entire Lowara range of pumps and related products, with multiple search options and helpful project management facilities. The system holds up-to-date product information on thousands of products and accessories.

The possibility to search by applications and the detailed information output given makes it easy to make the optimal selection without having detailed knowledge about the Lowara products.

The search can be made by:

- Application
- Product type
- Duty point

Xylect gives a detailed output:

- List with search results
- Performance curves (flow, head, power, efficiency, NPSH)
- Motor data
- Dimensional drawings
- Options
- Data sheet printouts
- Document downloads incl dxf files

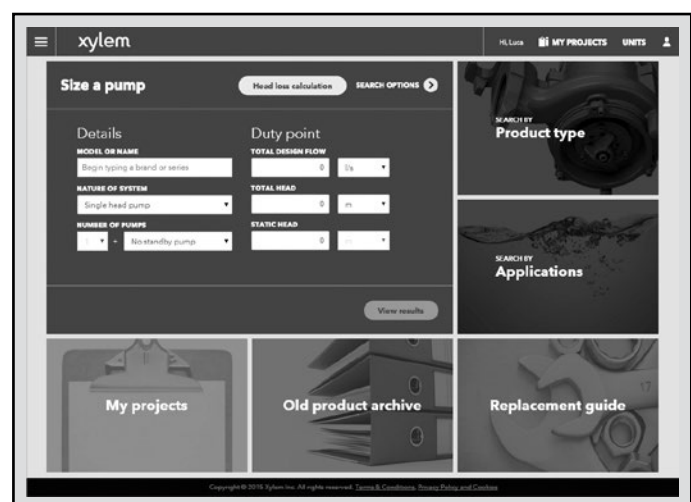

The search by application guides users not familiar with the product range to the right choice.

FURTHER PRODUCT SELECTION AND DOCUMENTATION

Xylect



The detailed output makes it easy to select the optimal pump from the given alternatives.

The best way to work with Xylect is to create a personal account. This makes it possible to:

- Set own standard units
- Create and save projects
- Share projects with other Xylect users

Every registered user has a proper space, where all projects are saved.

For more information about Xylect please contact our sales network or visit www.xylect.com.

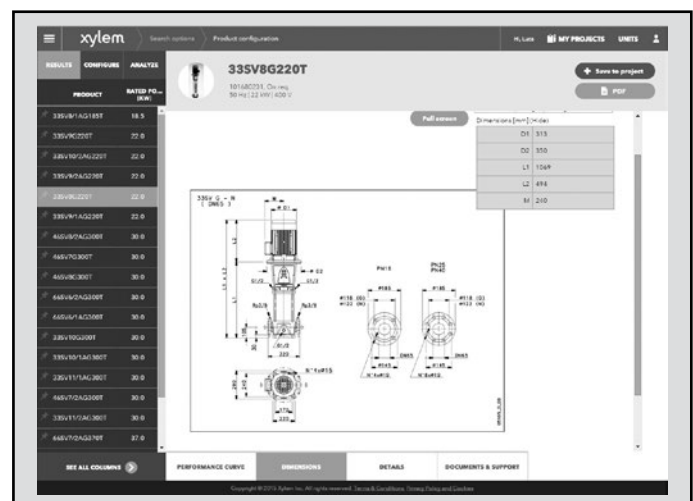

Dimensional drawings appear on the screen and can be downloaded in dxf format.

Xylem |'zīləm|

- 1) The tissue in plants that brings water upward from the roots;
- 2) a leading global water technology company.

We're a global team unified in a common purpose: creating advanced technology solutions to the world's water challenges. Developing new technologies that will improve the way water is used, conserved, and re-used in the future is central to our work. Our products and services move, treat, analyze, monitor and return water to the environment, in public utility, industrial, residential and commercial building services settings. Xylem also provides a leading portfolio of smart metering, network technologies and advanced analytics solutions for water, electric and gas utilities. In more than 150 countries, we have strong, long-standing relationships with customers who know us for our powerful combination of leading product brands and applications expertise with a strong focus on developing comprehensive, sustainable solutions.

For more information on how Xylem can help you, go to www.xylem.com.



For information and technical support
Xylem Service Italia Srl

Via Dottor Vittorio Lombardi 14
36075 - Montecchio Maggiore (VI) - Italy
Tel. (+39) 0444 707111
Fax (+39) 0444 491043
www.xylem.com/lowara

Xylem Service Italia Srl reserves the right to make modification without prior notice.
Lowara, Xylem are trademarks of Xylem Inc. or one of its subsidiaries
© 2021 Xylem, Inc.