

**DS (5.5÷7.5 kW) with QDC**

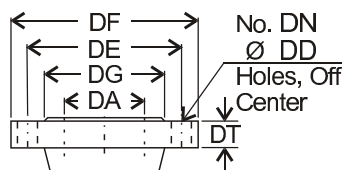
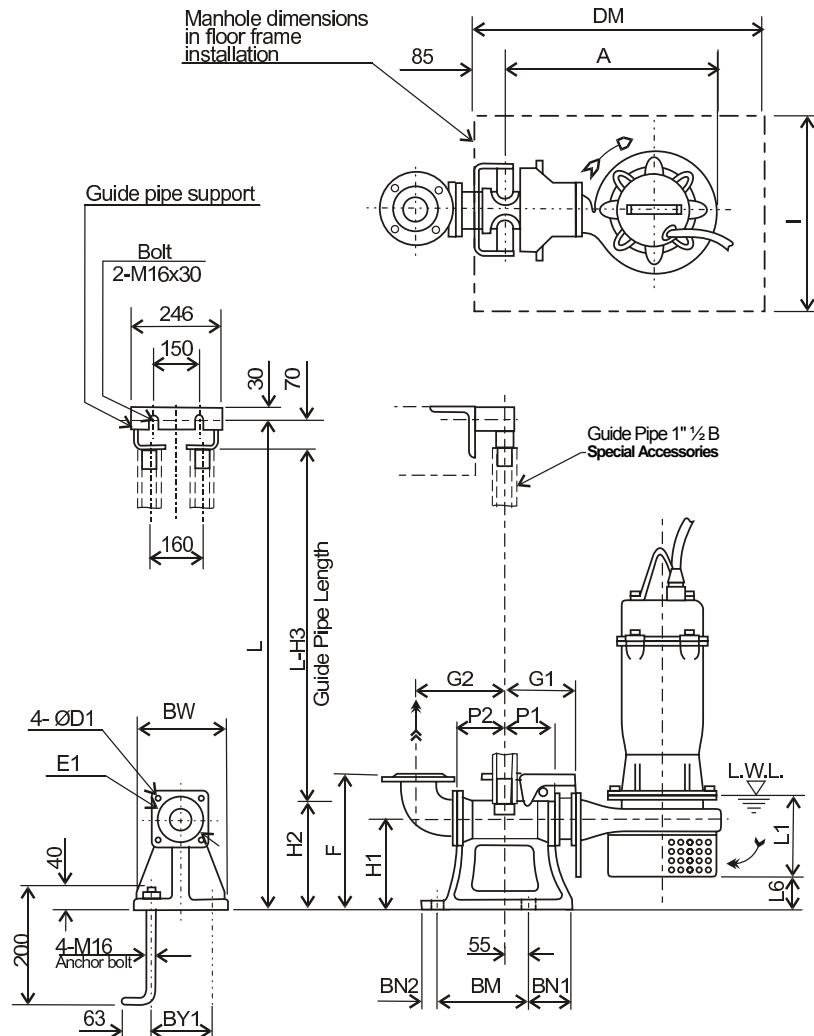

Type	DA	DE	DF	DG	DT	DN	DD
Round	100	180	220	156	21	8	19

Dimensions [mm]																								
Size	Model	Output [kW]	A	P1	P2	G1	G2	F	H1	H2	H3	L1 (*)	L6	BN1	BN2	BM	BY1	BW	DM	I	D1	E1	QDC Model	QDC Weight [kg]
100	100DS55.5	5.5	590	105	105	185	210	365	240	265	335	200	108	100	40	220	180	230	800	700	19	175	LL100	46
	100DS57.5	7.5																						

(\*) - L.W.L (Low Water Level)  
 - Operation is limited to 10 minutes at L.W.L.  
 - Operation is limited to 30 minutes with water level below top of motor